

SANGEAN

ATS-818 & ATS-818CS



FREE BONUS OFFER

- FREE with your ATS-818 or 818CS
 - ◆ DX Tips for Beginners a \$2.95 value
 - ◆ Radio Propagation a \$1.95 value
- Publications #0366 & #0327

The new Sangean ATS-818CS is a no-compromise receiver with full dual-conversion shortwave coverage plus long wave, AM and FM (stereo to headphone jack). A BFO is included for SSB and CW reception. A big LCD display, with dial lamp, shows: frequency (1 kHz on SW), 24 hour time, battery indicator and signal strength. The receiver features an RF gain, AM wide-narrow selectivity, keypad entry, manual tuning knob, plus 45 memories. The built-in cassette recorder lets you record directly off the air or via the built-in mic. Supplied with: AC adapter, external antenna adapter and wave guide. Requires 4 D and 3 AA cells (not supplied). 11 1/2" x 7" x 2 1/2".

List \$359.00 Order #0367 \$299.95 \$219.95 (+\$7)

The Sangean ATS-818 (not shown) is the same but without the built-in cassette recorder. One year limited factory warranty on both models. List \$299.00 Order #2754 \$209.95 \$169.95 (+\$7)

SANGEAN

ATS-808

Smart styling, compact size and exceptional performance combine to make the Sangean ATS-808 a favorite among SWBC listeners. Coverage includes LW, MW, all SW and FM (stereo to headphone jack). Five tuning methods: keypad entry, auto scan, manual scan, memory recall and manual two-speed rotary tuning. The attractive tri-colored LCD display shows:



frequency to 1 kHz, signal strength, memory status, dual UTC/local clock and band. A wide-narrow selectivity switch really helps in the crowded shortwave bands. Other features include: hi-low tone control, wide-narrow switch, local-DX switch, external antenna jack (mini), 45 memories (18 for SW) and dial lock. Includes stereo earphones and case. 7 1/2" x 4 1/2" x 1 1/2" 2 Lbs. Requires six AA cells (optional). One year limited warranty. Many think the ATS-808 is the best receiver Sangean ever made. It was not wildly popular because of the lack of SSB. If you want an excellent receiver at a bargain price, (with a tuning knob!), and do not need SSB this receiver is for you.

ATS-808 Discount Price

Order #0351 \$169.95

On sale for only \$139.95 (+\$7)

ADP-808 AC Adapter

Order #1665 \$8.95 (+\$2)*

*Free shipping if bought with ATS-808

USED

RECEIVERS

Call our toll free number (1 800 431-3939) to request our free used equipment list published every two weeks.



NIR-10



The NIR-10 allows reception of difficult to read signals and reduces listener fatigue. Operates on radio receiver audio outputs then provides its own volume-adjustable processed audio to an external 3 to 8 ohm speaker (not supplied). The NIR-10 reduces or eliminates white/pink noise, ignition noise, static interference, RTTY interference, and power line noise. PEAK function reduces white noise interference. The Notch Filter mode removes multiple heterodynes and acts in 3 milliseconds. Band Pass mode has continuously adjustable center frequency, selectable bandwidths (.25, .6 and 1 KHz), vertical-skirted filters and greater than 60 dB ultimate rejection.

JPS NIR-10 Order #2237 \$319.95 (+\$5)

The NIR-10 SWL version is the same as above but features bandwidths of 1.8, 2.4 and 3.0 kHz. JPS NIR-10 SWL Order #2721 \$319.95 (+\$5)

The JPS AC to 12 VDC power supply powers any of the JPS filters. (*Free shipping with filter) JPS PS Order #3085 \$15.95 (+\$2)*



THE COMPREHENSIVE GUIDE TO MILITARY MONITORING

By S. Douglass. Provides the information you need to effectively monitor all types of military communications on shortwave, VHF and UHF frequencies. Reviews equipment, systems, major military bases, monitoring play books and even black projects ©1994 Universal Electronics 280 p.

Order #3301 \$19.95



EUROPA HF-225



The special edition *Europa* version of the HF-225 provides optimized features and performance for the demanding DX'er. It looks virtually the same as the HF-225 but features the following enhancements:

- The IF filter bank has been changed to include higher specification filters.
- Resulting filter values include: 2.2 kHz, 3.5 kHz, 4.5 kHz and 7.0 kHz.
- Filter chokes have been replaced by quality magnetically shielded chokes.
- Filter selection diodes are now replaced by low capac. switching diodes.
- Filter select decoupling capacitors are bypassed by new "chip" capacitors.
- The D-225 FM/Synchronous AM detector is factory installed.
- The KPAD-1 wired keypad is provided.

A strong choice for the serious SWBC DXer looking for excellent selectivity and straight-forward operation.

Lowe Europa List \$1199.95 Order #3347 \$949.95 (+\$9)

universal radio inc.

Universal Radio, Inc.
6830 Americana Pkwy.
Reynoldsburg, Ohio
43068-4113 U.S.A.

800 431-3939 Orders & Prices
614 866-4267 Information
614 866-2339 FAX

◆ HUGE CATALOG ◆

Our new 108 page catalog is bigger than ever, with everything that is new for the listener, ham or scanner enthusiast. Available FREE by fourth class mail or for \$1 by first class mail.

Universal Radio ...
Serving Listeners Since 1942!

STORE HOURS

Monday - Friday 10:00-5:30
Except Thursday 10:00-8:00
Saturday 10:00-3:00
Sunday CLOSED

Visa, Mastercard or Discover card.
Prices & specifications subject to change.

NASWA Notes

Richard A. D'Angelo
2216 Burkley Drive
Wyomissing, PA 19610

Seaon's greetings to all members. It's hard to believe that another year has passed so quickly.

The election to fill the four open seats on the Association of North American Radio Clubs ("ANARC") Executive Board is now complete. Elected to a two-year term which commences on January 1, 1995 are: Rich D'Angelo, Dave Marshall, John McColman, and John Vodenik. Congratulations! They join Harold Cones, Mark Meece and Bill Oliver who have one year remaining on their terms. Currently, the new Executive Board is in the process of determining its own Chairman for 1995 while the 1994 Executive Board reviews the financial situation of the association. Also, work is continuing to select the North American Shortwave DXer of the Year, North American Specialty Band DXer of the Year, and the International DXer of the Year award winners for 1995. In keeping with recent traditions, these awards will be presented at the annual Winter SWL Festival in March by the Voice of NASWA and ANARC, Marie Lamb.

ANARC SWL Ham Net

Tune in Sunday mornings at 10 A. M. Eastern Time on 7240 LSB for the latest in shortwave listening, DX tips, and up to the minute hobby news. Contributors share their DX tips via their own amateur radio stations or by telephoning a "gateway" station who then broadcasts the relayed tips. Net Controls Bob Brown KW3F, Hausie WB4JSP, and Tom Sundstrom W2XQ, host an always lively gang of DX monitors. (Best heard in the eastern half of NAm)

Our members that also tune scanners may be interested in the following information from club member Dave Marshall. The All Ohio Scanner Club (50 Villa Road, Springfield, OH 45503-1036) is expanding its area of coverage, effective January 1, 1995, to include the Northeastern United States. The "American Scannergram", the AOSC's newsletter, averages 44 to 48 pages a month, and will be expanded several pages to accommodate the new columns. Membership

Welcome to the following new NASWA members -

Bill Amann Jr., Circleville, OH
Mike Balistreri, Novelty, OH
Rupert Charles Bell, Lansing, MI
William M. Bindas, Oak Ridge, NJ
James D. Curry, North Attleboro, MA
Thomas M. Finrow Esq., La Mesa, CA
Paul K. Gough, Killingworth, CT
Jennifer A. Griffin, West Des Moines, IA
Edward J. Holmes, Clifton, NJ
Terry W. Johnson, Burlington, IA
Osman Kaynak, Torrington, CT
Terry Kelly, Santa Rosa, CA

Carl Lewandowski, Devon, PA
Robert McElwee, Mason, OH
Donald Puro, Ann Arbor, MI
Robert Remschel, Morristown, NJ
William Rudolph, Birmingham, AL
Pedro J. Santa, Hato Rey, PR
Bill Shaffer, Toledo, OH
Conrad Stephen Sorensen, Sugarland, TX
Max Strauss, New City, NY
Ralph Thomas, Salinas, CA
David Robert White, Cheyenne, WY
Neil Widerman, Irvine, CA

Our Motto is - "Unity and Friendship"

dues for the All Ohio Scanner Club are \$18.00 for members in the United States, \$21.00 for Canadian memberships and \$28.00 for all other countries. For a membership application, send an SASE to the All Ohio Scanner Club at 50 Villa Road, Springfield, Ohio 45503-1036, or send e-mail to davem0911@aol.com from any onlineservice or computer bulletin board that has access to the Internet. A sample copy of a recent issue of the "American Scannergram" is available for \$3.00. Tell Dave that NASWA sent you!

Occasionally I am asked if the Journal accepts paid advertising. The answer is NO. The ads you see on the inside front and back covers are run on an exchange basis. Universal Radio and Gilfer send out the club's promotional fliers with their merchandise. This provides our club with many new members. In exchange, we carry product announcements from these two excellent

hobby vendors to keep our membership informed about the latest goodies available in the marketplace. This exchange arrangement has been beneficial for all involved. Please remember to support the folks that support the hobby!

Recently, I received information from Miltronix (P.O. Box 3541, Toledo, OH 43608) about their services. The firm specializes in the repair and restoration of R-390 and R-390A communication receivers. They offer module repair and alignment to complete remanufacture. Miltronix has repaired and remanufactured over 200 R-390 and R-390A communications receivers. If you are interested in purchasing an R-390 or R-390A, need repair or remanufacturing work performed on your unit, you may want to contact Miltronix about their services.

That's it for this month. Enjoy this month's JOURNAL; it's another good one.

Calendar Of Events

- Dec 16** - Meeting, Philadelphia Area NASWA Chapter. Kulpsville Holiday Inn, Kulpsville, PA. 7:30 PM Contact Dan Cashin (215)446-7831
- Dec 16** - Meeting, The Boston Area NASWA Chapter, 7:30 P.M. Friday, October 21, 1994; Our new meeting location is The Lexington Club, Route 4/225, Lexington, Mass. The new location is 1/4 mile West of Route 128 exit 31. For more information contact: Paul Graveline - Telephone: (508) 470-1971 or Internet: 74007.3434@Compuserve.com. You may also use the Boston Area SWL section on Tom's BBS at (617) 356-3538.
- Dec 17** - The Miami Valley DX Club (All band orientation) meets on the third Saturday of each month at 1 PM. Locations vary but are announced in advance. For info, call the MVDXC (614) 471-9973 Or, send a SASE to MVDXC, Box 292132, Columbus, OH 43229-8132
- Dec 20** - Meeting, N.E. Ohio SWLs. Cuyahoga County Library, 9089 Brecksville Rd., Brecksville, OH (Rt. 21, just South of Rt. 82). 7:00 PM. For info send SASE to: NE Ohio SWLs, c/o Donald J. Weber, P.O. Box 652, Westlake, OH 44145-0652
- Jan 2** - The Tidewater SWLs meet on the first Sunday of each month at 6:30 PM. For info, call Joe Buch, (804) 721-2782.
- Mar 16-19** - The 8th Annual Winter SWL Festival, Kulpsville Holiday Inn, Kulpsville, PA. Registration form in this month's Journal or SASE to Winter SWL Fest, PO Box 591, Colmar, PA 18915

Members are invited to submit items to be included in this calendar to Bob Brown.

Musings

This column provides a forum whereas members can express comments, ideas, and thoughts about NASWA or the SW radio hobby. Please feel free to comment on anything presented this month (or previous months). Opinions expressed here are solely those of the submitters. Please submit all Musings to Bob Brown, 238 Cricklewood Circle, Lansdale, PA 19446 or via email - 74756.1557@compuserve.com

John A. Figliozzi, 45 Algonquin Road, Clifton Park, NY 12065

As per WWCR.... I don't waste any time listening to the political commentary programming there. Rush Limbaugh upsets my stomach enough...I don't need to hear those even more radical (to my political sensibilities) than he! However, I am concerned about the kind of picture any overseas listeners that WWCR might have are able to piece together about us from listening to the cast of characters carried. If this is their only source of information about us that picture must be awfully skewed. In fact, looking at the "independent" SW station roster broadcasting from this country, one would have to assume that we are a nation comprised of religious and political fanatics, commercial hucksters who listen to Christian contemporary and country music. (WRNO does have football and some Cajun programs, though!)

As per Rich Cuff's comments on Easy Listening... As for the column, I think it's fine the way it is. It is a bit disconcerting to witness the dissipation of several SW services, the premature (in my opinion) embrace of satellite transmission at SW's expense, etc. However, I have worked in the cable television field for 15 years now. The new DBS service—DirecTV—that is being touted as a death star to cable was first touted as effective competition to cable—you guessed it—fifteen years ago! I think it's fair to say that cable will be around for many years to come—just as radio has survived television for, what, fifty years or so? SW, like domestic radio, will undoubtedly continue to undergo changes, including changes in the way SW is utilized in international broadcasting, but it will continue to have a place in the mix, as it were. Having said that, I see no reason why the "Easy Listening" column should change to include radio programming from other technologies or sources. Unlike most consumers of programming, SWLs as a group <<do>> care about how their programming gets to them. And it should come as no surprise that their method of choice is SW! Therefore, if "Easy Listening" should change at all, it should expand its scope slightly to document the changing use of SW in delivering programming and information to its audience.

That is not to say that we (SWLs) are not interested in programming from NPR, CBC domestic via clear-channel MW outlets, and even satellite. Let those sources develop their own outlets or, if you're crazy enough, start a computer BB on the subject! Just keep "Easy Listening" what it is.

I suspect that some of this "excitement" over local placement and satellite is inflated by the fact that the solar cycle is near its nadir, satellite delivery is new (relatively), and the world geopolitical situation is unusually stable (again relatively). All of these factors will change (the latter one, too, although I do not delight in that prospect), and SW will be rediscovered for its (for now) forgotten advantages. (Witness the shortsightedness of the VOA's Bethany decision. It doesn't take a genius to realize that that decision will be revisited in the not-too-distant future.)

That's all for now. All the best!

73s, John

Richard A. D'Angelo, 2216 Burkey Dr., Wyomissing, PA 19610

It was an honor to be re-elected by the ANARC Club Representatives to another two-year term on the its Executive Board. Since 1991, there was been a remarkable decreased in bickering and complaining among the member clubs while ANARC's Executive Council (which was renamed the Executive Board under an amended constitution passed in 1993) quietly set out the association's agenda which has focused attention on its committees. I have been lucky to serve along side some excellent people in this hobby and the new Executive Board is no exception. Although many of the Executive Board members are active in other clubs, each of the seven elected members taking office in January are members of our club!

Speaking of ANARC's committees, the Contest Committee which is chaired by our very own Harold "Dr. DX" Cones (one of the Radio Professors!) is planning a super North American DX Championship in early 1995. Similar to the championship held two years ago, The European DX Council and South Pacific Association of Radio Clubs are expected to participate. A number of rules changes are being made too. This event promises to be a tremendous affair so begin planning to participate now. Many years ago our own James Young dominated the contest thanks to hours of planning and preparation. Last year NASWAnS captured the first three places in the standings. Let's continue the club's fine tradition in this event.

73 - RAD

FRENDX: Twenty Five Years Ago....

Among the new members was Alvin Drehman of Miami, FL. Renewing members included: Oliver Ferrell and Don Billingsley (3rd year), and Bruce Churchill (4th year). Awards Chairman Warren Nordgren sends a list of members awarded certificates which included Alvin Sizer (Worldwide DXer - 100 countries) and Craig Koukol (Worldwide DXer - 75 countries). Word of the retirement of Happ Station host Eddie Startz was carried in the Headquarters Report. In the ANARC Report column, it was reported that Gerry Dexter has become the Chairman of the Man of the Year committee. Friendx included a picture page featuring Bill Eddings, Al Niblack, Bill Matthews, a bearded Dan Ferguson, Gregg Calkin, and Gerry Dexter. In the Shortwave Center, Al Sizer talks about numerically rating DX skills, Al Niblack writes about knowing your receiver, and Jan Turner discusses reporting to LatinAmerica. Forty-nine reporters contributed to QSL Report with Tom Alleman, David Alpert, Ernest Behr, Gregg Calkin, Gerry Dexter, Robert Estand, Marlin Field, Dr. Earle Hall, William Matthews, Henry Michalenka, Al Reynolds, Alan Roth, Robert Shepard, Alvin Sizer, Bill Sparks and Dr. Tom Williamson among the notables. The featured QSL OF THE MONTH was Radio Clube de Cabo Verde. Dan Ferguson's Log Report saw contributions from 51 reporters which included: Ernest Behr, Gregg Calkin, Gerry Dexter, Bob Estand, Dan Ferguson, Grady Ferguson, Marlin Field, Bob Hagerman, Glenn Hauser, Del Hirst, Danny Jamison, Bill Martin, Henry Michalenka, Al Niblack, Bob Padula, David Potter, Ed Shaw, Al Sizer, Bill Sparks, John Tuchscherer, and Richard Wood. In Al Niblack's Flashsheet, 15 reporters provided the latest in hot DX including news of a tri-lingual program called "Melodies to Remember" over Radio Nacional de El Salvador.

Easy Listening

Richard D. Cuff
P.O. Box 4512
Timonium, MD 21094-4512
CompuServe: 73651,153
GEnie: R.CUFF
Internet: rcuff@memtec.com

Thanks, Mr. Postman

I must have struck a sensitive cord with last month's exhortation, as I received a veritable avalanche of correspondence. I received more than seven letters and E-mails, more than double that of any previous single month since I've been editing the column. I received a lot of good feedback and ideas, part of which I've summarized here. I am especially grateful to those who provided specific program commentary, especially for those stations and programs I don't often listen to myself.

WWCR

Peter Siitelo of Strange Creek, WV (sorry for spelling errors) occasionally enjoys Tom Valentine's **Radio Free America** between 0300 and 0500. The 5065 signal, even though out of traditional North American broadcasters' bands, is superior in Central WV. Pete considers the program both "interesting and entertaining".

Bob Montgomery of Levittown, PA also suggests **Radio Free America**, and considers it WWCR's best talk show. Bob also sent along these program notes:

Sundays, 0100: **Word Prophecy** is a call-in political talk show; also has interviews with underground newspapers.

Sundays, 0200: **The American Way** is a series of essays about world religions and secret societies.

Sundays, 0300: **Spectrum**, a communications program with extensive shortwave coverage. Last year they originated live from the Kulpsville Winter SWL Festival. Interviews are often featured.

Sundays, 0600: **Tempered Steel** is a music program that, Bob says, requires a liberal

interpretation of the definition of "music". Bob isn't sure if the music is religious or satanical.

Tuesday through Saturday, 0000: **Voice Of Liberty** is a political call-in show hosted by Rick Tyler, often with interviews. Occasionally lively discussion.

Tuesday through Saturday, 0100: **Jack McLamb Show** is another political talk show with a somewhat more soft-spoken host than often found on the airwaves, more of a "pleasant" muckraker.

Tuesday through Saturday, 0200: **You Make The Call** is about financial investment strategies, including collectibles.

Bob also noted that two former program hosts, Tom Donahue, and Kurt Saxton, are currently serving prison time....

Other Political Programming

John Figliozzi of Clifton Park, NY, author of the comprehensive **Shortwave Radio Guide** of program schedules, pointed out timings for other parliamentary programming. Radio Australia's **Parliament Program** is easiest to catch in North America Fridays 1130 UTC. Radio New Zealand International features **Focus On Politics** Mondays 1020 UTC. CBC's **The House** is no longer carried on Radio Canada International but is featured on the Northern Quebec Service 1500 UTC Saturdays (factoring in the Daylight Time changes) on 9625 kHz.

Other Broadcasters

Bret Pollack of Baltimore (soon to be my home) wishes I covered other broadcasters in as much detail as I spend on the BBC. Unfortunately, it's not easy getting detailed program previews. Perhaps I should write an automatic schedule request letter that pops out for each broadcaster every three to six

months. Keep in mind that the BBC puts out, roughly, 12 hours of fresh English language programming, not counting repeats, every day. By comparison, most European broadcasters put out 30 minutes to 2 hours fresh daily.

John McColman of Chesterfield, VA especially enjoys the CBC Northern Quebec Service. Especially during daylight hours, it's one of the best alternatives on the air.

Programming Beyond Shortwave

You may recall a musing several months back where I requested comments regarding the inclusion of non-shortwave programming in the column. Feedback has been universally *against* any dilution from a SW-only emphasis. Even though other means of program delivery will continue to develop, the tie that binds NASWA is SWBC, not satellite, nor FM, nor MW.

General Appreciation

Steve Bies sent me a nice note interlaced with artwork...even a simple "attaboy" helps reassure me the column continues to have relevance.

HCJB December Highlights

Tuesdays, 0200 and 0600 to the Americas: **Master Control** covers lifestyle issues and Christian themes. Learn how to fight fair in a marriage, or sell cookies nationwide! Airings directed elsewhere include Mondays 0930 and 1800.

Thursdays, 0130, 0530: **Ham Radio Today** includes the following topics in December: 8th, grayline effects, herringbone antenna; 15th, Lazy-H antenna, sweet spot DXing; 22nd, sudden ionospheric disturbances, Marconi antenna.

Saturdays, 1800, and Sundays, 0230 and 0600 to the Americas: **Solstice** is produced by HCJB's Australian studio and presented by teenagers for teenagers. Music and discussion are featured.

Tuesdays through Saturdays, 0430: **Nightsounds** is probably the most soporific program on shortwave, and for good reason: it's meant to be that way...I've heard this

program on for years on a local FM station, and it's a nice program to go to sleep by. This is a perfect reason to make your bedside clock radio a shortwave clock radio!

Deutsche Welle in December

Friday, December 8th, 0130 and 0150: **Come To Germany** looks at the 300-year old tradition of Christmas fairs—the Munich fair, for instance, draws nearly three million visitors. If you're looking for a unique place for your last-minute shopping, convince your spouse it's worth the trip!

With Larry Wayne's retirement, **Random Selection** has, sadly, breathed its last. Its Sunday time slot has been taken by the German language course **German By Radio**, and the new program **Religion And Society** has taken the Sunday time period vacated by **German By Radio**.

Program previews for Deutsche Welle are now available via the Internet. It appears Deutsche Welle has a World Wide Web page, www-dw.gmd.de, and an ftp site, [ftp-dw.gmd.de](ftp://ftp-dw.gmd.de). E-mail addresses include harald.schuetz@dw.gmd.de and solbach@dw.gmd.de. With the introduction of this Internet Connection, Deutsche Welle's excellent program guide, **Tune In**, will scale back its frequency from 6x a year to 4x a year in 1995.

Canadian Forces Network

Radio Canada International has a weekday 30-minute program targeted to Canadian Forces involved in peacekeeping operations in the former Yugoslavia and, perhaps, Haiti; the edition I sampled includes an extended newscast, a timely news report from the region and phone messages from loved ones. These messages are both humorous and poignant and definitely not something you hear every day. It was good to hear Wojtek Gwiastda's voice as program host—I hadn't heard him on the air since the RCI cutbacks several years back. Tuesday through Saturday at 0300 on 6000, 9725, and 9755 kHz targeted to the Caribbean (why I'm speculating Haiti), and Monday through Friday 0600 targeted to Europe on 6050 (via Skelton), 6150, and 9760.

BBC December Highlights

I received mixed reviews about my emphasis on the Beeb in my recent E-mail activity. Those folks who already subscribe to *BBC Worldwide* considered the summaries to add little value; others that don't subscribe appreciate the effort. What I may try to do is to scale back the level of detail on the BBC and aim for a bit more diversity. Let me know what you think!

The holiday season and the continuing UN Year Of The Family are the featured topics for December.

Christmas and New Year Programs

Thursdays, beginning December 8th, 2330: **It's A Funny Old World** is a three-part 30-minute series of programs and comic songs and sketches hosted by Stewart Collins. First airing Wednesdays at 1530; also repeated Thursdays 1030.

Saturday, Christmas Eve, 1502: A traditional component of the British holiday scene is the 90-minute **Festival Of Nine Lessons And Carols** from Kings College, Cambridge. The story of humanity's creation, fall, redemption, and salvation is interspersed with traditional and modern carols. Repeated Christmas Day 0930.

Sunday, Christmas Day, 2200: **The Queen's Christmas Message** is a highlight of seasonal programming. This five-minute address first airs at 0900, and is repeated at 1500.

Thursday, December 29th, 2330: **Two Cheers For 1994** takes a 30-minute satirical look at events of the past year. First airs Wednesday 1530; also repeated Thursday 1030.

Saturday, December 31st, 2330: **Omnibus** features a New Year's Special. No other details are provided, but it's my experience that **Omnibus** is always worth the listen. Repeated January 4th 1001 and 1930.

UN Year Of The Family

Aside from those programs listed last month that continue in December, here's another suggestion:

Mondays, 0445: **I've Got Something To Tell You** is a continuing eight-part 15-minute series of children from different cultures voicing their opinions on topics like First airing Sundays 2015; also repeated Mondays 0915.

Other News and Features

Sundays, beginning December 18th, 2330: **In The Market Place** is a four-part 30-minute series looking at the economic system of capitalism as it exists in the 20th century, with a discussion of how it works, when it fails, and where it is going for the future. First airs Sundays 1401; also repeated Mondays 0630 and 1001.

Monday, January 2nd, 0101: **The World At The Time 1895** is a single 45-minute program looking at the events that would have made top news stories 100 years ago, had radio been commercially available. The program also looks at the general perspective one would have had of the world at that time. First airs Saturday December 31st 1901; also repeated Monday 1515.

Music

Monday, December 19th, 0101: **The Miller Legacy** is a single 45-minute program commemorating the 50th anniversary of the disappearance of bandleader Glenn Miller. Comments from people that knew Miller and a celebration of his music are featured. First airs Saturday December 17th 1901; also repeated Monday 1515.

Quiz Shows

Tuesdays, beginning December 27th, 0230: **Inspiration** is a new five-part 30-minute quiz show on inventions and inventors hosted by Chris Stuart. The resident panel of experts also suggests new inventions that would improve the quality of our lives. First airs Sundays 2030; also repeated Mondays 1215 and 1715.

Season's Greetings

May your holiday season and 1995 bring you unparalleled peace, prosperity, and good listening—see you in 1995!

73 DE Richard

Shortwave Center

Hans Johnson
7529 Red Cravat Court
Columbia, MD 21046
CompuServe: 73042.3644
Internet: 73042.3644@compuserve.com

"HAWAII CALLS"

by Jerry Berg

On July 3, 1935, from the Banyan Court at the Moana Hotel in Waikiki, Webley Edwards began broadcasting a show called "Hawaii Calls," carrying "real Hawaiian music, direct from the Islands" to the mainland. It was relayed to the Mutual Broadcasting System's mainland BCB network by way of the RCA point-to-point shortwave station at Kahuku. During the 1930's and 40's it was often heard by DXers on frequencies in or near the 16 meter band. For 40 years, "Hawaii Calls" carried island music to an eager mainland audience.

Although Hawaii has for many years been a NASWA SWBC target, first by way of the long-closed VOA relay station in Honolulu and more recently via WWVH, there have been no Hawaiian sounds on shortwave for many years. Webley Edwards died in 1977, and the "Hawaii Calls" microphones stood silent until 1992 when broadcast veteran and Honolulu businessman

Bill Bigelow revived the program, staging live performances and recording radio broadcasts at the Hilton Hawaiian Village Hotel. The first performance of the new "Hawaii Calls" was on

October 2, 1992 when Bigelow walked up to the mike on stage at the Tropic Showroom of the Hawaiian Village and spoke the opening line, "This is a call from Hawaii," just as Edwards had 57 years before. The name of the program was changed to "The Sounds of Aloha" in January 1994. Shortwave listeners can again hear the program, now by way of shortwave station KWHR in Naalehu which opened in December 1993. While only a small part of World Harvest Radio's programming week, which is mainly religious in nature, it is good to hear Hawaiian programming, from Hawaii, once again.

PROGRAM	TIME (GMT)	FREQUENCY (KILOCYCLES)
THE VOICE OF AMERICA HONOLULU, T.H.		
This is a verification of your report of 9 November 1945, on 17,800 kilocycles.		
KRHO		English News is presented on the hour -GMT

**THE
SOUNDS OF ALOHA®**
Hawaii's International Radio Program

The "Sounds of Aloha" is part of a one-hour live performance of Hawaiian music featuring a nine-member cast of singers and musicians and two Hula Girls. A different guest star or group is showcased each week. The program is performed as an early evening cocktail show, usually from the Shell Bar of the Hilton Hawaiian Village Hotel on Waikiki Beach. It is produced on Thursday evenings, at least three times a month from the Hilton and once a

month from a different island or another Oahu vacation spot. The final 30 minutes of the show are taped and become "The Sounds of Aloha."

The program's producers feel that music and dance are vital parts of Hawaii's culture, but that it is becoming harder and harder for visitors to find authentic Hawaiian music ("Na Mele O Hawaii"). "The Sounds of Aloha" features both contemporary artists and new and up-and-coming singers, musicians and groups. Names you will hear on the program include Sam Kapu III, the Peter Moon Band, the Brothers Cazimero, Henry Kapono, Jimmy Borges, The Krush, Ho'okena, Auntie Genoa Keawe, Loyal Garner, Olomana, Herb Ohta, Eddie Bush, Don Ho and even the Kamehameha Schools Alumni Glee Club. The cast does a rehearsal from 1730-1815 local time, followed by a one-hour show for guests at 1830-1930. The last 30 minutes of the show become the program that is broadcast the next weekend. The program was originally conceived as an "infomercial," inviting listeners to visit Hawaii and showcasing Island music. It has a definite promotional sound. Producing the program is quite an undertaking and involves the selection of music and performers, rehearsals, sound engineering and scripted dialogue. The cast is headed by musical director Nina Kealiiwahamana, an experienced hand in Hawaiian recording circles and a former member of the original "Hawaii Calls" program.

Program preparation begins six weeks in advance, with a review of the song list and research



on the writers, dates and background of each composition. Program producer and host Bill Bigelow, who has been president of the Waikiki Rotary Club and chairman of the Visitor Industry Education Council, fills in the details of the script and hands it over to "Sounds of Aloha" guru, Ron ("RJ") Jacobs. RJ's job is to make sure the program goes according to plan, and assist with the post-production process. The

latter is done at Audio Media, a Honolulu recording and mastering studio. RJ also helped assemble the network that airs the program (he was one of those who helped launch Casey Kasem's "American Top 40" program in 1970). The man who strolls onstage to get the audience prepped, set a mood of anticipation and help get the crowd to understand cues is Krash Kealoha, formerly of KCCN when it was the first full-time Hawaiian music station. He uses an old-fashioned "Applause" sign to prompt the audi-



750 Kilocycles
399.2 Meters
2.500 Waves

K G U

HONOLULU HAWAII

THE WESTERN OUTPOST OF NBC
Operated by The Honolulu Advertiser

Honolulu, T. H., Sept 2, 1938

Aloha, Mahalo nui loa! That's the way we say Hello, and thank you very much. Your communication asking for verification of KGU reception has just been received.

You heard RCA S. W. carrying our program -

This verifies your reception of KGU - - -

Your information was too meager for verification

Try for us again. KGU broadcasts from 6:00 a. m. until 11:30 p. m. Honolulu Time.

When it's 6:00 o'clock in Honolulu it is

8:30 Pacific Standard Time
9:30 Mountain Standard Time
10:30 Central Standard Time
11:30 Eastern Standard Time

ence and maintain a tradition of old-time radio. Visitors celebrating anniversaries, birthdays and other notable events are likely to be singled out and recognized.

When the show first went on the air, the audio engineers had had little ex-

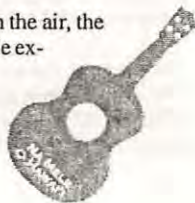

SOUNDS OF ALOHA PRODUCTIONS

673 Kaulana Place • Honolulu, Hawaii 96821 • Phone 808-377-3537 • FAX 808-373-4424

perience with live music. They operated out of a converted bread truck. (Once they parked it in a no-parking zone and the police arrived an hour before show time, ready to have the truck towed away. Bigelow, then a member of the Honolulu City Planning Commission, made a few phone calls and received a reprieve until proper approval could be obtained.)

Two versions of the show are produced and duplicated for syndicated distribution. One version is 27 minutes long, the other 24 minutes, the difference being the amount of commercial time built in. Stations work their own market commercials into the program, but every show includes commercials for Hawaiian Airlines, Outrigger and Hilton hotels, and the Hawaii Visitors Bureau.

The first station to take the program was KRAE in Cheyenne, Wyoming. It is now broadcast over several Hawaiian BCB stations, plus BCBers in 28 states, Vancouver, B.C. and Agana, Guam, an FMer in Melbourne, Australia, and KWHR. KWHR carries the program at 0800 UTC on 9930 kHz. (It used to be simulcast over WHRI's South Bend transmitter as well, but that appears to have been dropped.) The program announces that it has a mailing list, which you can get on by

writing to them at International NewsFeatures, Ltd., 1600 Kapiolani Blvd. (Suite 1100), Honolulu, HI 96814. The address of program production headquarters is Sound of Aloha Productions, 673 Kaulana Place, Honolulu, HI 96821. The producers invite listeners to check out "The Sounds of Aloha" if they are in Hawaii. The program setting permits visitors to have a drink and relax before dinner. Reservations are suggested, and because "Sounds" does neighborhood programs once a month, be sure to call to see when they are going to be in Waikiki. The Honolulu reservations number is 808-947-7993. The program is free to the general public, but there is a one-drink minimum. Validated parking is provided in the Hilton Garage at \$2.50 per car. Drinks are available from 1700 on, and several Hilton restaurants are available for dinner following the show. But if you can't make it to Hawaii, get up early Sunday morning and catch this interesting program. And do it soon. Forty years was a long run for the original "Hawaii Calls." Things have a way of disappearing from shortwave if you don't act quickly.

(Prepared in part from material supplied by "The Sounds of Aloha." KGU and KRHO QSLs from the Committee to Preserve Radio Verifications.)

Takayuki Inoue Nozaki "TIN" is a very active and very widely travelled Japanese Dxeer. What follows are some Brazilian station histories provided to us by TIN via his Relampago DX. Thank you very much TIN.

Brazilian Overview

by Takayuki Inoue Nozaki, "TIN"

Radio Guaiba was inaugurated officially on April 30, 1957. The station specializes in newscasts, information and sports, just as Radio Gaucha does. ZYE852 6000 khz is operated with a "Philips do Brasil" (10 kW) transmitter into a 1/2 wave dipole 12 meters high.

ZYE853 11785 khz has a similar setup with a 7.5 kW transmitter.

They are on the air from 0500-0100 from a site in Ilha da Pintada, which is 25 kilometers north of Porto Alegre.



Radio Gaucha was established officially on February 8, 1927 as the second station in Porto Alegre. They specialize in news, sports and information and have exchange agreements with other South American stations, hence their slogan "A Fonte da Informação". ZYE851 6020 khz is operated with a "Philips do Brasil (10 kW) transmitter into a 1/2 dipole 13 meters high. ZYE850 11915 khz has the same setup but its antenna is only 12 meters high. Both outlets are on from 0600-0100.

Radio Marumby started on June 6, 1979 officially. Its name is taken from a regional tribe "Marumbi" and the station is operated by a evangelic organization "Grup Mathus Iensen".



They are on 9665 khz with a new (1991 made) EASA transmitter of 10 kW into a 1/2 wave dipole 12 meters high. The station has trouble QSLing as they lack both personnel and supplies. When I visited them, they had no letter paper, pads or a typewriter! They have plans to broadcast on 11725 khz using a 10 kW "Philips do Brasil" transmitter but they do not have a license yet.

Radio Garuja uses an old Philips 10 kW transmitter on 5980 khz into a 1/2 wave dipole 15 meters high. They have programs for rural listeners between 0810 and 0600.

Radio Anhanguera ZYE691 4915 khz uses a Harris 10 kW transmitter fed into a 1/2 wave dipole 15 meters high between 0500-0000. ZYE442 6080 khz is operated with a SNE 5 kW

transmitter in a 1/2 wave 9 meters high while ZYE441 has a 10 kW version with a 12 meter high antenna. The latter two outlets are on from 0600-2200.

Radio Brasil Central ZYE690 4985 khz has an EASA 10 kW unit fed into a 12 meter high dipole and is on from 0400-0000. ZYE440 11815 khz has a "Philips do Brasil" transmitter of 7.5 kW fed into a 18 meter high dipole that is on from 0600-1900. They use to have programs for long-distance listeners but those were discontinued several years ago.

Radio Clube Paranaense ZYE725 operates on 6040, 9725 and 11935 khz with BYGTON 7.5 kW transmitters fed into dipoles from 0600-1900 (Sundays 2000)

Radio Universo ZYE727 uses SNE brand 10 and 15 kW transmitters on 6060, 9565 and 11765 khz into dipoles of various heights. The 49 and 31 meter band outlets are on the air 24 hours, but the 25 meter band one is scheduled only from 0600-0000.

Radio Difusora ZYK864 is here operating with only a 2.5 kW of their DIGITRON transmitter into a 12 meter high dipole from 0600-0000.

Super Radio Tupi Bearing no relationship to the old Radio Tupi (11765 khz) this station operates ZYG865 on 4975 24 hours a day using a ELVITEC 1 kW transmitter into a 1/2 wave dipole. They are operating with the equipment of the former Radio Iguatemi which was located in Osasco.

Radio Globo is only on 6120 khz now, operating ZYK968 with a STP transmitter of 7.5 kW into a 1/2 wave dipole 12 meters high.

Radio Gazeta ZYE965 5965 khz and ZYE963 9685 khz use SNE 10 kW transmitter into 1/2 wave dipoles from 0600-2400.

Radio Bandeirantes ZYE956/7/8 operate on 6090, 9645 and 11925 with 10 kW Harris transmitters into 1/2 wave dipoles 24 hours a day.

Radio Record ZYE950/1/2 operate with SNE 10 kW and 7.5 kW transmitters on 6150, 9505 and 11965 khz from 0600-2100.

Radio Cultura use 7.5 and 1 kW Philips do Brasil transmitters with 1/2 wave dipoles on 6170 (ZYE959) 9615 (ZYE960) and 17815 (ZYE961) khz.

Radio Caraja 4885 khz with INDELMON 1 kW transmitter into a half wave dipole 15 meters high from 0500-1900 and 1700-2400

Radio Novas de Paz Founded in 1988, this station operates ZYE726 with EASA 10 kW transmitters on 6080 and 9515 khz from 0700-2400. Programming is not in parallel.

Radio Clube de Rondonpolis operates on 4955 khz with a SNE 2.5 kW transmitter into a 1/2 wave dipole antenna 12 meters high from 0400-1800.

Radio Portal de Amazonia is off for the moment but operates an 800 watt homebrew transmitter on 4775 khz from 0400-1300.

Radio Brasil Tropical produces its own programs but relays Radio Cultura de Cuiaba from 0000-0400 on 5015 khz using between 250 and 500 watts from their ELVITEC transmitter.

Radio Educaçao Rural uses a Telefunken do Brasil 10 kW transmitter on 4755 khz from 0400-2400 (Sundays 0500).

Radio Tropical has only been on since December 1992. On 4855 khz, they use a SNE transmitter of 2.5 kW into a Yagi antenna about 6 meters high. They are on from 0600-2230.



Radio Difusora de Jatai, the first broadcaster in Jatai, operates ZYF694 on 4935 khz with a SNE 2.5 kW transmitter into a half wave dipole 12 meters high.

Radio Difusora de Aquidauana operates ZYF900 on 4795 khz using a IVAPE transmitter of 1 kW and a half wave dipole antenna.

Radio Clube de Dourados started transmissions in 1981 where they operate ZYF907 with a MORATO transmitter of 3.5 kW into a half wave antenna.

Net Notes

Radio Prague has joined the ever-growing ranks of international radio stations on the Internet. For now, they're limited to e-mail, but after the first of the year, with the help of a sponsorship from Digital, they plan to provide news in text and audio form to the World Wide Web and gopher. You can reach Radio Prague at cr@radio.anet.cz.

Deutsche Welle has also jumped into the net with a big splash. They've set up a very nice looking World Wide Web server at <http://www-de.gmd.de/english/index.html> containing schedules, election results, and other items of interest from Germany.

Radio Sweden's "MediaScan" program is now available in digitized form over the net. You can get it by anonymous ftp from <ftp://ftp.funet.fi/pub/sounds/>, but if you're in North America, it's recommended that you grab the files from the North American mirror site at <ftp://town.hall.org/radio/Mirrors/RadioSweden/>.

Latin Destinations

Don Moore
11434 140th St.
Davenport, IA 52804-9538



Hola amigos! Bienvenidos to this month's Latin Destinations column. Several times in the past few months while tuning around I've come across Brazil's Radio Clube Paranaense on 6040 and 9725 and Radio Universo on 6060, 9565, and 11905, both from the city of Curitiba, capital of the southern state of Parana. Each time it has reminded me of interesting tidbits I've heard about this city, from reading and from a few friends who have been there until last week I was prompted to spend an afternoon at the university library doing a little research.

I've always believed that one thing that makes Latin America interesting is the way that certain areas sometimes defy everything we have ever believed about them. For example, when we think about First and Third World countries, we assume that the Third World needs to become more like the First, and that the First World has a lot to teach the Third. Certainly Brazil is an example of this. With one of the most unequal income distributions in the world, it has many problems including widespread poverty and vast slums in its cities. Who would ever imagine that a Brazilian city could be a model for cities around the world, both First and Third World? Yet, that is what Curitiba has become.

In the late-1960s, like all cities in Latin America, Curitiba was experiencing a population boom due to rural-to-urban migration. The population had increased from around 140,000 in the early 1940s to about 600,000, just 25 years later. A small group of local architects and engineers dismayed by what uncontrolled growth was doing to the beautiful small city they had grown up in did not want Curitiba to become another center of gray concrete and high skyscrapers. They approached the mayor, Ivo Arzua, with the suggestion that the city's development should be controlled through careful urban planning that would focus on small-scale, balanced, and - decades ahead of their time - environmentally-sensitive projects. Arzua not only liked the idea, but held a nationwide

contest to come up with an overall plan. Mayor Arzua then went out and sold the idea to the city's people, leaving the architects and engineers to put the plan into practice. The initial steps worked so well that in 1971 a member of the original group, architect Jaime Lerner, was elected mayor, the first of three terms he would serve. Since then Lerner has been the driving force behind Curitiba's progress.

Some of the changes were easy to put in effect, such as a ban on the construction of high-rise buildings. Others took time. When Lerner first proposed closing some streets to traffic to create outdoor pedestrian shopping malls, store owners thought he was nuts. But, he convinced one block to try the idea for a month. Shoppers loved the idea so well, that by the end of the month shopkeepers on other blocks were pleading for the same. Today, Curitiba's downtown pedestrian malls are the center of city life. The malls are lined with fruit trees and flower beds, which Curitiba's street children are paid to maintain.

Keeping Curitiba green has been part of the plan since the beginning. Since the early 1970s, the city has purchased over 1.5 million trees, which volunteer citizens have planted along city streets and avenues. Not only have trees & flower beds been planted along many of the city's streets, but today Curitiba is a park-lover's paradise. When the plan was first proposed, Curitiba had 5 square feet of parkland per citizen. Today it has 550 square feet, despite a 164% population increase - to over 1.5 million - during the same period. Part of the Iguazu River flowing through town was diverted through a 7 km artificial channel before it arrives to the city's parks, making it easier to keep pollution under control in the numerous artificial lakes.

WORLD'S BEST BUS SYSTEM?

Another goal of Lerner's group was solving the transportation problem that any growing

city has. Elsewhere in Brazil, large cities built superhighways and planned subways. But, as Lerner said, "While other cities thought about a subway for the year 2000, we wanted a good public transport system now." The result was five special multi-avenue channels radiating out from the city center, much like the spokes on a wheel, with special avenues for fast limited-stop buses and parallel avenues for slower local buses. Other local bus routes link the five spokes. The system has gradually evolved into a marvel of efficiency.

The key to the fast lanes is special large plastic tubes at the bus stops. Passengers pay their fare upon entering the tube, not boarding the bus. The other end of the tube interlocks with special wide bus doors allowing eight people to enter or exit the bus per second. Add to this special three-coach linked buses that hold 270 people, and Curitiba's high-speed buses move more people than a subway system, just as quickly, but at a fraction of the cost of a subway. City officials from around the world, including New York, Vancouver, and Lyon, have come to Curitiba to take a look. The system works so well that even Curitibaanos who have cars prefer to use the bus system. Curitiba has the second highest number of cars per capita in Brazil - one for every three inhabitants, but the lowest use of autofuel per capita among Brazilian cities. And in Curitiba, traffic jams are almost unheard of.

RECYCLING EVERYTHING

Recycling is quite the buzzword in the USA these days, but few know that Curitiba was one of the first cities in the world to begin a widespread voluntary recycling campaign. By the early 1990s, just when recycling was really starting to pick up here in the states, seventy percent of Curitiba's households already recycled trash. Over 70% of Curitiba's garbage is recycled or composted, with most sold to local industries. The city's recycled paper alone is estimated to save 1,200 trees a

day.

Recycling even reached the slums. In a 'food for trash' policy, the city government bought surplus produce from farms around the state, which was then bagged and trucked into the slums to be exchanged, a bag of food for a bag of sorted, recyclable trash. A similar program gives slum residents a free bus pass for a bag of trash. The result? Amazingly clean slums with well-fed inhabitants and without rats, flies, and other vermin usually found in such neighborhoods, which in turn has led to a decrease in communicable diseases in the city. Furthermore, slums dwellers have been given most of the jobs in the recycling program, bringing income into those neighborhoods.

The concept of recycling is found everywhere in Curitiba. Old buses have been turned into mobile vocational classrooms to take job-training into the squattertowns. Sheep graze in the city park, both to keep down the grass and to naturally fertilize it. An abandoned quarry has been turned into a rock concert arena. Even the mayor's office (located in a city park for easy public access) is recycled - a log cabin made out of old telephone poles. In Curitiba, simplicity applies to everyone.

Curitiba has far more interesting features than I can go into here. It's biggest resource, obviously, is imagination and a willingness to try something different. Of course, as Jaime Lerner himself admits, "Our city isn't a paradise. It has most of the problems of other cities. We haven't got rid of the favelas (slums). But when we provide good buses and schools and health clinics, everybody feels respected." So, amigos, the next time you tune in a station from Curitiba, remember, it's not just another Brazilian city. Curitibaanos believe it is the best place on Earth! Hasta luego ... Don.

A bibliography for the above column is available upon request.

FOR SALE: I have Popular Communications magazines for 1983, 1984, 1985, 1986, and 1987 for sale at \$15.00 a year. Contact Vahan Yazarian, 1918 1/2 Blake Street, Berkeley, CA 94704. Phone (510) 843-1005 evenings.

FOR SALE: Grundig Yacht Boy 400 SW receiver in like new condition with original box, leather case, window antenna, and instruction book. Only a few months old. The Yacht Boy 400 has been rated the top portable by Passport. Price is \$180.00 postpaid. Ed Pyatt, 10-B Bainbridge Avenue, Hampton, VA 23663-2302. Phone (804) 727-5762.

Listener's Library

T. J. "Skip" Arey WB2GHA
P.O. Box 644
Waterford Works, NJ 08089
America Online: TJAREY
Internet: TJAREY@AOL.COM

Some shortwave hobbyists are loath to admit it but we do owe a great deal to the amateur radio community. The technology of shortwave as we know it today depends in large part to the efforts of the amateurs who, in the early days of radio regulation, were banished to the netherworld of wavelengths shorter than 200 meters. Since those early days, The American Radio Relay League has helped many folks get involved in amateur radio. They have also provided the publications that have taught these folks the radio art. A couple of League publications have become the standard texts of the radio hobby, not just for hams, but for listeners too. With the holiday season just around the corner, you may want to add these works to your wish list.

THE ARRL HANDBOOK FOR RADIO AMATEURS

1994 Edition

Published by

The American Radio Relay League

225 Main Street

Newington, CT 06111

(203) 666-1541

\$25.00

1184 pages

ISBN 0-87259-171-9

(1995 Edition due out Oct. 1994, cover price \$30.)

Each fall brings the anticipation of a new ARRL handbook. Each year it is thicker, more full of essential radio information. I bought "The Handbook" for five years before I ever even thought of getting my ham license. The radio art has come a long way since then. You don't see many tube designs anymore (except for amplification circuits) and amplitude modulation is just a paragraph. You will see designs for space communications and digital signal processing. The Handbook always seeks to keep folks up to date with the latest radio technology. Even though I make generous use of the information found in this book in my

amateur radio pursuits, I find I am just as quick to turn to the Handbook for guidance in my SWL adventures.

The Handbook is broken down into chapters covering every aspect of radio design and practice. There are several chapters that are especially useful to the SWL. The chapter covering radio receiving principles will give you all the information you need to make intelligent choices when it comes time to plunk down your hard earned cash on your next receiver. Also, the chapter on troubleshooting and repair will help you figure out what to do when your receiver goes dark. This is important information regardless of if you plan to take the repair job on yourself or farm it out to someone else. The chapter on propagation will help you put those hard stations in your log by teaching you how to listen when the listening is best. The sections on antenna theory and design will help you come up with the best wire for your real estate. If you're into learning about how all this magic occurs, the chapters on electronics fundamentals will teach you much, as will all the other sections of the book. As I said earlier, I got five years of knowledge out of The Handbook before I ever got on the air. If you have been enjoying Joe Buch's Technical Topics, "Walk Through Your Receiver," The Handbook will expand upon that knowledge.

An often overlooked subject is that of setting up your listening post. Whenever I do workshops with beginners (and even some old timers) I get quite a few questions on the topic. One of the first resources I point folks to is the chapter in The Handbook on the subject. Serious radio listening requires a lot more thought than plugging in a receiver and throwing a length of wire out of the window. The Handbook covers every aspect of "shack" design from the power coming out of the wall to the ergonomics of your table.

As I said, each year The Handbook gets a little bigger. The 1995 edition should be ready by

the time you read these words. The 1995 edition is 1200+ pages long with new sections covering communication modes, circuit construction, a refresher course in radio mathematics, and much more. Who knows, after a couple of years you may get hooked and seek out an amateur radio license class in your area. Yeah, The Handbook will even show you how to become a ham.

THE ARRL ANTENNA HANDBOOK

*Published by
The American Radio Relay League
225 Main Street
Newington, CT 06111
(203) 666-1541
732 Pages
ISBN 0-87259-473-4*

I must confess that I have limped along using my old ARRL antenna handbook for far too many years. The ARRL has done a total revamping of their antenna classic that even made me sit up and take notice.

Face it, hams have a lot of antennas considerations that SWLs don't have to stay up nights worrying about. When your sending a signal down a wire, dozens of factors come into play. It often seems that length of transmission line and antenna structure exist for the sole purpose of keeping your signal from getting out to other folks. Antenna tweaking is the order of the day, wrestling with the antenna system to achieve optimum efficiency, to get every last watt out there bouncing off the atmosphere. And then there's the atmosphere, hams are constantly fighting the propagation demons that send their signals off to Nibi Nibi when they are trying to work somebody in Freedonia. As a listener, this stuff might not seem all that important. Wrong!!!

A clear understanding of antenna design and fundamentals is essential to long term listening success. Anyone can hear their first fifty countries using the whip on their portable. Most folks can log their next fifty with a good old longwire. Then things start to get interesting. Antenna characteristics begin to have an effect on your ability to log stations. Now you begin to sweat the same details as your amateur radio colleagues. Antenna

tweaking becomes a tool for the listener.

As I said above, amateur radio operators have been at the foundation of much of what we know today about radio signals in the shortwave bands. This body of knowledge extends to antenna design and theory as well. The ARRL Antenna Handbook is an exhaustive compilation of that body of knowledge. In its new large format, the handbook gives the reader dozens of antenna applications, many of which can be adapted to SWLing with little more than a slight adjustment in the formulas applied to the wire. Armed with this book, the dedicated SWL will come up with antennas that will address the specific problems presented by frequency, propagation, and their personal real estate.

Like all great antenna tomes, this book contains an extensive chapter on safety. Stringing wire and swinging ladders must be done in a manner that will not endanger life and limb. Another chapter that contains information often left unconsidered is The Effects of the Earth. In this section you will learn the importance of soil conductivity and directivity. Once you wade through this section you will begin to understand why shortwave broadcasters pick some of the exotic locations they do for transmitter sites.

I don't want to scare anybody away but you will need to play with some math to get the best use out of this book. Don't worry, you won't run across anything that your calculator can't handle. In addition, The ARRL has added something to this latest edition of The Antenna Handbook to help you along. Software!!! The \$30 cover price includes a disk of IBM PC compatible programs. While some of these are specific to the construction of ham antennas, the programs on propagation will aid you in your listening pleasure.

SHORTWAVE SIDELINES

A few months back I decided to go for the FCC Commercial General Radiotelephone Operators License. I had read in several ham publications that the test would be a snap for anyone with sufficient amateur radio savvy since the GROL test shared a large portion of its question pool with the FCC Amateur Extra Class License. Also, the new volunteer examiner system for commercial licenses

makes getting to sit for the GROL a snap. (I found a VE in my own hometown. VE lists can be obtained by contacting your local FCC field office)

Well, after about a month of studying I was able to pass the GROL exam without a twitch, thanks largely to . . .

THE GENERAL RADIOTELEPHONE OPERATOR LICENSE PREPARATION COURSE

Published by
National Radio Examiners
W5YI Group, Inc.
PO Box 565206
Dallas, Texas 75356
(817) 461-6443
2 IBM PC Compatible Disks and
Question Pool Book
\$39.95

FCC multiple choice tests lend themselves well to computer assisted learning systems. The program allowed me to study the entire question pool in several ways. I was able to step through the entire pool and get a feel for what I knew and didn't know. I could also give myself practice tests made up of random selections from the question pool in the same fashion as the actual exam. The program would even allow me to print out practice exams to give a more real feel to the test taking process. A unique "go wrong" feature allowed me to concentrate on studying those questions I was constantly missing. For example, the program showed me that I needed to spend some time studying basic impedance formulas. With this tool and an hour per night, I am confident anyone with a basic understanding of radio electronics can sit for the GROL exam. Give it a shot folks, it sure looks good on your resume.

FOR SALE: Drake SPR-4 receiver in mint condition and used very little. Complete with manual, crystals ranging from .5 to 22.0 MHz, "AMECO" preamplifier model PLF-2, and Drake matching MS-4 speaker. Price \$225.00 plus shipping. Stanley W. Sims, 9805 S. Keeler, 1-B, Oak Lawn, IL 60453. Phone (708) 425-2981.

FOR SALE: Panasonic RF-B60 in excellent condition with manual and wire antenna. Price \$140.00. Joe Hanlon, 3121 Fairdale Road, Philadelphia, PA 19154.

FOR SALE: MFJ-956 preselector tuner, \$25.00. MFJ-959B antenna tuner/preamp with power supply, \$65.00. Both include shipping and are factory new in original cartons. Jerry Klinck, 43 Lein Road, West Seneca, NY 14224. Phone (716) 675-7509 evenings after 9:30 pm. No collect calls, please.

FOR SALE: ICOM R71A . Gilfer modified so preamp works in MW band. Original box and manual. Price \$720.00 including shipping in United States. NASWA FRENEX/Journals complete 1979-1992, \$10.50 a year or all 14 years for \$100.00. Popular Communications complete 1986-1988, \$12.00 a year or all 3 years for \$30.00. PWBR 1993, \$7.00. All prices include shipping in United States. All others inquire. Cashiers check or money order, please. Paul Brouillette, 611 Illinois Street, Geneva, IL 60134. Phonw (708) 208-6406, not collect.

FOR SALE: Kenwood TS-940S, AT all filters and technical manual. Clean, not used for contesting. Price \$1,400. May be seen at Gilfer SW, Park Ridge, NJ. JPS NRF-7 Noise Remover and Filter Unit. CW and SSB wide and narrow modes, notch, peak, notch with SSB and CW, data mode. Speaker, headphone outputs. Originally \$250.00. Clean, \$150.00 including shipping. Datong FL-3 Multi-mode Audio Filter, autonotch, SSB, CW, and RTTY notch, peak, hi, lo, speaker, headphone and line outputs. Clean, \$175.00 including shipping. Shipping outside the US is extra. Tom Sundstrom, PO Box 2275, Vincentown, NJ 08088-2275. Phone (609) 859-2447 evenings/weekends or use one of my E-mail addresses.

Walking Through Your Receiver (Part 3—The Frequency Synthesizer)

In our two earlier articles we saw our signal go from the input connector to the mixer. This time we will look at the other input to the mixer. This input comes from the local oscillator (LO). We'll learn what the LO does, why it is needed, and some characteristics of a good LO. We will again use the Watkins-Johnson (WJ) HF-1000 as the basis for our description.

The LO is a signal generator that permits the receiver to tune to different signals. Without the LO, you could have a very good receiver but it would only hear one station. (If that was 7.425 MHz, you might go to heaven when you die but you wouldn't have much radio fun in the interim.) You will understand how the LO permits the receiver to tune after we study the function of the mixer.

Up to about 1970 all short-wave receivers used a free-running, variable-frequency, LO. Most of those oscillators drifted with temperature and voltage changes. About this time the frequency synthesizer became available in commercial short-wave radios. The LO in the WJ HF-1000 is a frequency synthesizer.

There are four important specifications related to the LO synthesizer:

- **Settling Time** determines how quickly the receiver can change frequency. The shorter the better. The chugging sound you hear on certain portable radios as you tune them is caused by a slow settling time.
- **Frequency Stability** defines how accurately the receiver displays the received frequency as a function of temperature.
- **Phase Noise** contributes to how closely a weak signal can be to a strong signal without noise sidebands around the strong signal masking the weak signal. The lower the phase noise the better.

- **Minimum Step Size** determines how closely you can set the receiver synthesizer to the desired frequency.

There are two types of frequency synthesizer in common use.

"Direct Digital Synthesis" (DDS) is one type. The DDS synthesizer uses a computer to trace out an approximation of the sine wave of the desired frequency. You change frequency by commanding the computer chip to work at a different rate.

DDS synthesizers can change frequency quickly. They find application in amateur radio equipment. Here the settling time between transmit and receive frequencies is important for the new digital transmission modes. DDS exhibits short settling times. Computer chip speed limits the upper frequency limit of DDS synthesizers.

The WJ HF-1000 uses another type of synthesizer. A free running oscillator feeds a digital divider. The divider output frequency is at the frequency of the reference standard. The digital divider is programmable. You change frequency by changing the division ratio.

A phase detector measures the difference in phase between the standard and the divided oscillator signal. The detector generates an output voltage that is proportional to the error in phase. If the phase of the free-running oscillator deviates from the reference, a voltage pulls the free-running oscillator back in phase. This type of synthesizer is called a "Phase-Locked-Loop" (PLL).

A synthesizer makes all its output frequencies from a master reference frequency. A stable master frequency generator makes the synthesizer output have the same high stability. Running at only one frequency allows the master oscillator to be very stable. Quartz crystal reference oscillators are common.

Professional multi-receiver sites often use a central master frequency standard based upon oscillations of cesium atoms. The WJ HF-1000 has the ability to lock its frequency to such an external standard. Figure 3 shows how the HF-1000 automatically senses and switches to an external reference. The phase detector, shown as a circle with a slash through it, slaves the internal reference to the external reference. The "TCVCXO" is a temperature compensated voltage controlled crystal oscillator. It serves as the receiver's standard when an external reference is unavailable. The accuracy of the master oscillator determines the ultimate accuracy of the receiver's frequency readout.

Engineers specify frequency stability in parts per million. An error of 1 Hz at 1 MHz is an error of one part per million. Another way to specify such an error is $1 \times 10E-6$. That means 1 times 10 to the minus 6 power. Ten to the minus six power is one millionth. Receiver ads use both kinds of specification. They both mean the same thing.

Good specifications state a specific stability over a temperature range. The WJ HF-1000 has a master frequency generator that is accurate to better than one part per million. At 10 MHz the accuracy is within 10 Hz. This specification applies over a temperature range of 0 to +50 °C. In a temperature-controlled environment

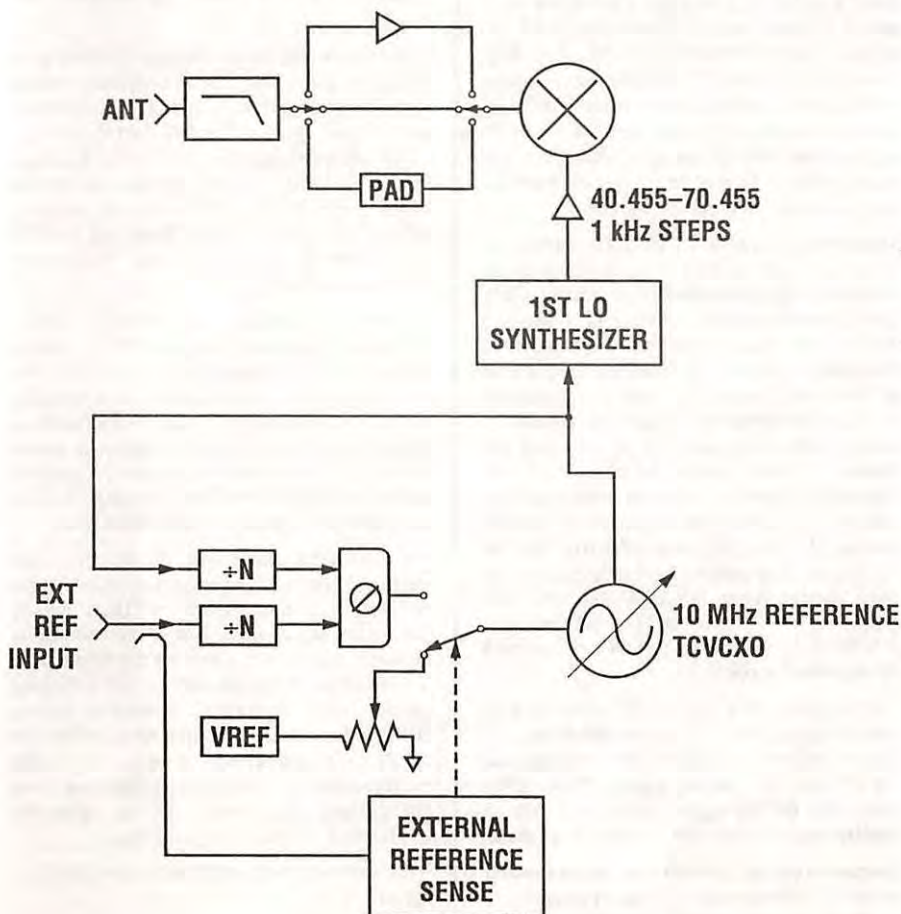

Figure 3. The local oscillator synthesizer permits selection of the receive frequency to an accuracy determined by a precision reference frequency.

the performance is probably close to one part in 10 million or 1 Hz at 10 MHz. Cesium atomic standards are accurate to better than one part in a trillion or $1 \times 10E-12$ over 24 hours.

Frequency accuracy is an easy specification to check. Set your receiver AGC time constant to FAST. Tune to a frequency standard station like WWV or CHU in the USB mode with a BFO offset of zero Hz. The beat note will be lower in frequency than you can hear. The beat (difference) frequency will show up as a slowly varying oscillation of the signal-strength meter.

Beware, the signal received via sky wave from these standard stations has a relatively poor stability compared to the accuracy of the original signal. The ionosphere constantly moves. It rises and falls causing the reflection point and the path length to constantly change. The path length variation causes the source to appear to be moving toward or away from you at any instant. This apparent motion causes a Doppler error on received signals.

I once worked at a NASA facility in California. I had access to precise frequency standards, counters, and phase-locked receivers. (Talk about the kid in the candy store.) I configured one of our receivers to track the received frequency of WWV on 10 MHz. I made sure all frequency translations and measurements had the same reference, a single crystal standard with a short term stability of one part per billion. I phase locked the receiver to the incoming signal. A counter measured the variations in the receiver frequency as it tracked the Doppler shift. Variations of two or three Hz on this one-hop path were clearly evident. So even though your HF-1000 can read out frequency to a resolution of 1 Hz, that resolution is not useful unless the signal you are measuring is on ground wave.

Why is phase noise important? Receivers with poor phase noise performance are subject to high noise levels when trying to receive a weak signal next to a strong signal. Phase noise sidebands on the strong signal will fall on nearby weak signals and interfere with them.

Engineers can design both types of synthesizer to have low phase noise. Think of phase noise as small, random changes in the frequency of the local oscillator. This noise shows up as low amplitude phase modulation sidebands on the

local oscillator signal. That noise gets modulated onto received signals in the mixer. The noise is highest near the carrier and usually falls off the farther you go from the carrier.

The WJ HF-1000 data sheet specifies phase noise both directly and indirectly. The direct specification states that the phase noise is 110 dB below the carrier (-110 dBc) at a separation of 1 KHz from the carrier. This specification is meaningless because WJ did not state the bandwidth of the noise measurement detector. Engineers usually normalize such measurements to a 1 Hz bandwidth. But you can't be sure unless the manufacturer clearly specifies how they present the test data. Few do.

Receiver specifications often specify the impact of phase noise indirectly. The indirect method specifies phase noise by specifying its impact on received signals. The WJ data sheet says, "With a desired signal of 25 μ V in the 3.2-KHz IF bandwidth, the desired signal-to-noise ratio (SNR) is greater than 20 dB, when an undesired signal 70-dB higher in amplitude and 35-KHz removed in frequency is present." They call it "reciprocal mixing".

A lack of standard test methods makes comparison of specifications or test results between different manufacturers difficult. You must rely on independent phase noise tests like those commissioned by Radio Netherlands or the American Radio Relay League to really be sure of what you are getting. Recently designed radios in the \$500 and up price range usually have adequate phase noise performance.

To keep phase noise low, the WJ HF-1000 designers limited the synthesizer LO step size to 1 KHz. Fine tuning down to 1 Hz is done in the digital signal processor. We'll talk about that in a later article. Limiting the step size to 1 KHz allows WJ to produce an LO with good phase noise performance. Phase noise, settling time, and minimum step size are all related in a PLL synthesizer. Engineers trade performance of one type for another to achieve the desired performance for the particular application and receiver price class.

That's it for this month. Until next time, stay tuned.

Listener's Notebook

Al Quaglieri
P.O. Box 888
Albany, NY 12201-0888
CompuServe: 75122,74
Internet: alq@echonyc.com

Chris Lobdell
P.O. Box 146
Stoneham, MA 02180-0146
CompuServe: 75720,253

HO HO HO INDEED! Once again it's that nutzoid time when we vainly attempt to enjoy the best DX of the year while dealing with such distractions as shopping, family, friends, and peace on earth.

My heartfelt, year-end thanks to all of you who continue to make this column possible. And here's a broad hint to all you would-be Santas: old Scrooge here can't possibly edit *LN* and transcribe newsy bits from DX programs as well. Would it that several elves among you would help with the latter, this column'd be unbeatable!

COPYRIGHT NOTICE Items credited to BBCM are copyright by the BBC Monitoring Service and may not be reproduced without BBCM permission.

AZERBAIJAN *Radio Dada Gorgud* English 1900-1930 German 1930-2000 on 4958 (Radiomaalia/Shortwave News/Ben Krepp/Hans Johnson JIHAD DX))

BAHRAIN *R. Bahrain*, 6010, 2037-2106* Non-stop slow jazz mx program, ID at 2100 after time pips "Good evening, this is Radio Bahrain", then in to EE news then off 2106. Nothing noted on 9746. (Valko 10-29; NU #1296)

BOLIVIA 4410, *Radio Eco Reyes'* Director Gonzalo Espinoza is planning to relocate his station to Puerto Maldonado due to the fact that the economic situation in Reyes is very poor while things in Puerto Maldonado-Peru are quite good in this border town. (R. Mendez, PlayDX #811) Interesting...not only changing cities but countries as well! CL.

3390 *Radio Em. Camargo* 1500-0100

4939.2 *Radio Norte* 0916, ids by 0925

4985 *Radio Dif. Minería "La V de las Mayorías Nacionales"* 1000-0030

5123.6 *Radio Galaxia* 2330 ID as "Emisora Galaxia"

5910 *Radio Centinela "La voz Militar del Sud"* 1000-0200

5995 *Radio Loyola "La V de los sin voz"* 1000-0200

6095 *Radio Cosmos* Quechua programming from 0900-0930 and 0000-0200

(Hans Johnson + WRTH LA-NL/PLAY-DX/20-Nov-94/TROPICAL TUNING #30/Manuel Rodriguez-VENEZUELA)

BRAZIL *Rede Transamerica-Foz do Iguacu* broadcasts overnights on the frequency of *Radio Cultura de Foz do Iguacu* (6104.98). Switches back to R. Cultura at 1000 UTC. (Takayuki Inoue Nozaki/RELAMPAGO DX #61)

CAMBODIA 4910 *V. of the People of Cambodia* strong @1155 (09-Nov-94/Chuck Rippel)

CHAD *Radiodiffusion Nationale Tchadienne* programs are in French, Arabic and local languages (Sara, Kanembou, Moundang, Toupourri, Gorane and Massa Zakawa); sked:

0430-0730 French/multi 4904

1030-1600 French/multi 7120

1700-2200 French/multi 4904

(18-Nov-94/BBCM)

CIS As of 29 October, *Radio Moscow* officially changed its name to *Voice of Russia*. Contrary to last month's report in *LN*, Nepali broadcasts continue to be heard at 1230-1330 on 15470 and 7155 kHz.(BBCM)

GPR-2, St. Petersburg, complete schedule, updated October 7th and effective until 3-25-95:

0200-0400 *VO Russia* EE 7225K (Mon.)

0200-0400 *R. Slavyanka* 9715 (Tue-Sun)

0200-0600 *Golos Rossii* 7225K

0200-0700 *R. Rossii* 7265P

0300-0430 *VO Russia* EE 6035P

0300-1400 *R. Nadezhda* 11965K

0400-0600 *VO Russia* EE 9705P

0400-0800 *Golos Rossii* 9820P

0400-1500 *R. Nadezhda* 6045S

0430-0500 *Aum Shinrikyo* 6035P

0430-0500 *Aum Shinrikyo* 5905K

0430-0600 *VO Russia* EE 9865P

0500-0600 *VO Russia* EE 5905K

0630-0800 *Golos Rossii* 13650P

0730-1400 *R. Rossii* 12045P

1000-1100 *VO Russia* GG 9680K

1100-1500 *VO Russia* EE 9680K

1100-1500 *Golos Rossii* 13650P

1300-1500 *VO Russia* EE 15480P

1300-1600 *VO Russia* EE 12065P

1400-1600 *VO Russia* EE 15465P

1400-1600 *VO Russia* FF 21515P

1430-1500	<i>VO Russia</i> EE	6015K	2230-2300	<i>VO Russia</i> EE	7300P
1430-2000	<i>R. Rossii</i>	7340P	2230-2300	<i>VO Russia</i> EE	9890P
1500-1700	<i>VO Russia</i> EE	6015K (Sat-Sun)	2300-0500	<i>VO Russia</i> SS	9890P
1500-1700	<i>R. Al-Risalah</i>	6015K (Mo-Fri)	2300-0500	<i>VO Russia</i> SS	7300P
1500-1700	<i>VO Russia</i> EE	6035P	K = Kaliningrad (Bolshakovo)		
1500-2300	<i>Golos Rossii</i>	9715P	S = St. Petersburg		
1530-1600	<i>VO Russia</i> EE	7130P	P = St. Petersburg-Popovka		
1530-1600	<i>VO Russia</i> EE	5920K	VOR = <i>Voice of Russia</i> (formerly <i>R. Moscow</i>)		
1530-2200	<i>R. Nadezhda</i>	12015S	<i>Deutsche Welle</i> broadcasts via Russian xmts as follows:		
1600-1700	<i>VO Russia</i> EE	5965P	0100-0150	7355	Novosibirsk
1600-1700	<i>China Radio Int'l.</i>	12065P	0200-0250	7355	Samara
1600-1730	<i>VO Russia</i> AA	7130P	0800-0850	17675	Samara
1600-2000	<i>VO Russia</i> GG	5920K	0900-0950	9875	Irkutsk
1600-2200	<i>VO Russia</i> EE	9890P	1000-1050	15525	Samara
1600-2300	<i>Golos Rossii</i>	9820P	1000-1400	7340	Novosibirsk
1630-1700	<i>VO Russia</i> EE	7150P	1100-1130	5925	Irkutsk
1630-2100	<i>VO Russia</i> AA	9865P	1200-1320	7390	Novosibirsk
1700-1800	<i>VO Russia</i> Hungarian	5965P	1400-1800	7315	Samara
1700-1800	<i>VO Russia</i> Serbo-Croat.	7150P	1430-1650	7305	Novosibirsk
1700-1900	<i>VO Russia</i> EE	7325K (Sunday)	2200-2320	7315	Novosibirsk
1700-1900	<i>R. Slavyanka</i>	7325K (Mon-Sat)	2200-2400	5925	Novosibirsk
1700-2200	<i>VO Russia</i> AA	6035P	English programs are at 0200, 0900 and 1600 on 7355, 9875, and 7305 respectively. (Nikolai Rudnev-CIS)		
1700-2200	<i>R. Nadezhda</i>	6015K	<i>Mariyskoye Radio</i> is noted on 7200 around 0430 on Saturdays. Transmitter appears to be a 20-kW ex-jammer. (Nikolai Rudnev-CIS)		
1730-1800	<i>VO Russia</i> EE	5975P	<i>Radio Nadezhda</i> complete sked:		
1800-1830	<i>China Radio Int'l.</i>	7130P	0500-0600	Russian	9730 9490
1800-1900	<i>VO Russia</i> II	5975P	0600-0900	Russian	15460 15435 15175 12010 12005 11965 11665 11660 11630-* 9850 9775 9730 9575 9525 9490 7160 6045
1800-1900	<i>VO Russia</i> Slovak	5965P	0900-1000	Russian	15460 15435 15175 12010 12005 11965 11665 11660 11630-* 9850 9775 9730 9575 9525 9490 7160 6045
1800-1900	<i>VO Russia</i> II	7150P	1000-1400	Russian	15460 15435 15175 12010 12005 11965 11705 11665 11630 9850 9775 9730 9575 9525 9490 7140
1830-2100	<i>VO Russia</i> AA	7130P	1400-1700	Russian	17675 12015 11665 9775 9730 9580 7260 7255 6190 6185 6105 5935
1900-2000	<i>VO Russia</i> Albanian	5975P	1700-1900	Russian	17675 12015 11665 9775 9730 9580 7260 7255 6190 6185 6105 6015 5935
1900-2000	<i>VO Russia</i> Czech	5965P	1900-2100	Russian	6015
1930-2000	<i>VO Russia</i> Albanian	7300P	2100-2300	Russian	6015
2000-2030	<i>VO Russia</i> EE	5920K	(18-Nov-94/BBCM)		
2000-2100	<i>VO Russia</i> Hungarian	5965P	<i>Adygey Radio</i> (Maykop) announces itself as "Radio of the Adygey Republic from Maykop". (The Adygey Republic is located in southern Russia, to the		
2000-2100	<i>VO Russia</i> Serbo-Croat.	5975P			
2000-2100	<i>VO Russia</i> Italian	7300P			
2030-0000	<i>R. Rossii</i>	7335P			
2030-2100	<i>Aum Shinrikyo</i>	5920K			
2100-2200	<i>VO Russia</i> EE	7300P			
2100-2300	<i>VO Russia</i> FF	9865P			
2100-2300	<i>VO Russia</i> EE	5920K			
2100-2300	<i>VO Russia</i> EE	5975P			

northeast of the Black Sea.) It broadcasts in the Bzadogh (or Bzadugh) dialect of Adygey, one of the Circassian languages. Sked: 1800-1900 Kabardino/Arabic/Turkish 5935 (5905 alt) Mo, Fr

Kabardino-Balkar Radio (Nalchik) The Kabardino-Balkar Republic is in southern Russia, on the border with Georgia. Sked: 1830-1900 Kabardin 5935 (5905 alt) Su, We. **Adygey Radio** and **Kabardino-Balkar Radio** share transmitting facilities. (18-Nov-94/BBCM)

Radio Al-Risalah is a Muslim religious station operating Mon-Fri only. Russian programs from 1500-1700 on 6015 and 6095 kHz. (11-Nov-94/BBCM)

Here's the winter sked for **Radio Yerevan/Araks Radio Agency**:

0900-0930	Armenian	15370 15275	Su
0930-0945	English	15370 15275	Su
0945-1000	French	15370 15275	Su
1430-1500	Azeri	6065 5930 4990 4810	
1500-1545	Kurdish	6065 5930 4990 4810	
1545-1600	Turkish	6065 5930 4990 4810	
1600-1615	Ukrainian	6065 5930 4990 4810	
1615-1715	Armenian	6065 5930 4990 4810	
1715-1745	Russian	6065 5930 4990 4810	
1745-1845	Arabic	6065 5930 4990 4810	
1845-1900	English	6065 5930 4990 4810	
1900-1930	Persian	6065 5930 4990 4810	
1930-2130	Armenian	6065 5930 4990 4810	
2300-2330	Armenian	11970 11920 9685	
2300-2315	English	11960 9480	
2315-2330	French	11960 9480	
2330-2345	English	11970 11920 9685	
2345-0000	Spanish	11970 11920 9685	

Via the same transmitters come the following broadcasts from **Radio Intercontinental**:

0630-0700	German	15400
0700-0705	English	15400
0705-0715	Armenian	15400
2200-2230	German	9480

German program is *Mitternachtsgruss* (Midnight Call), English program is *Definition* (11-Nov94/BBCM)

Georgian Radio's external service announces a schedule of six English and four German broadcasts a day. However, most of these broadcasts have not been confirmed by monitoring observations. Here are those broadcasts that have been confirmed:

0730-0800	German	11805
1030-1100	German	11815
1100-1130	English	11815

The English service announces itself as "*Program Georgia*". (04-Nov-94/BBCM)

Follow-up to last month's report of **Abkhaz Radio** on 9373 kHz: BBCM reports no success at hearing this station, first reported by a listener in the CIS. (BBCM)

Radio Ukraine International sked as monitored:

0000-0100	German	11870 9620 7405 7240 7180 7135 6020 5915 4820
0100-0200	English	11870 9810 9620 7180 6055
0100-0200	Ukrainian	7405 7240 7135 6020 5920 5915 4820
0200-0230	Ukrainian	7405 7240 7135 6020 5915 4820
0230-0330	Ukrainian	7405 7240 7135 6020 5915 4820
0330-0400	Ukrainian	7405 7135 5915 4820
0400-0500	English	11870 9810 7180 6055
0400-0500	Ukrainian	7155 6020 5915 4820
0500-0600	Ukrainian	11870 11840 11790 9810 7180 7135 6055 6020 6010 5915 4820
0600-0700	Ukrainian	13720 11870 11840 11790 9810 7180 7135 6055 6020 6010 5915
0700-0800	Ukrainian	13720 11870 11840 11790 7135 6020 6010 4820
0800-0900	Ukrainian	13600 12030 11840 11780 9600 7240 6020
0900-1000	Ukrainian	13680 13600 12030 11840 11780 11705 9600 7240 6020
1000-1100	Ukrainian	13680 13600 12030 11840 11780 11705 9600 7290 7240 6020
1100-1200	Ukrainian	13680 13600 12030 11840 11780 11705 9600 7290 7240 6020
1200-1300	Ukrainian	13680 13600 12030 11840 11780 11705 9600 9560 7290 7240
1300-1400	Ukrainian	13600 12030 11840 11780 11705 9600 7290 7240 6020
1400-1530	Ukrainian	13600 12030 11780
1400-1530	Ukrainian	13680 11840 11705 9600 9560 7240 6020
1530-1600	Ukrainian	13680 13600 12030 11705 7290 7240 6020
1600-1700	Ukrainian	13720 12030 11840 11705 7290 7240 6020
1700-1800	Ukrainian	13720 12030 11840 11705 9610 6020
1800-1900	German	13720 12030 11840 9640 7280 6130 5940
1900-2000	Ukrainian	7405 7290 7240 6130 6020 4820
2000-2100	Ukrainian	13720 9810 7405 7290 7240 7180 6130 6020 5940

2100-2200 German 13720 9810 7405 7290 7240
7180 6130 6020 5940 4820

2200-2300 English 11870 7240 7180 6020 5940
4820

2300-0000 Ukrainian 7240 6020 5940 5915

2300-0000 Ukrainian 11870 9810 7180 6055 4820

(04-Nov-94/BBCM)

CLANDESTINE—AFRICA R. *Mogadishu*, 6870, (presumed) popped on suddenly at 0332 in the middle of a Koranic recitation. Unintelligible talk and local mx followed until 0400 fade. (Johnson 10-29, NU #1296).

VO Ethiopian People for Peace, Democracy and Freedom was noted signing on with a synthesized flute IS at 0328, into programs in Amharic. Frequency 6940 kHz. (Johnson/Kohlbrenner/Orr/Field/D'Angelo/Valko—DXpedition in PA/FINE TUNING)

Free Radio Voice of Ethiopian Unity (Amharic: *Yeh Yenetsa Radio Yeethiopia Andinet Dimts New*), hostile to the Ethiopian and Eritrean governments, emanates from *Radio Moscow's* transmitters. Sked is 1600-1700 in Amharic on 11945 kHz, Su & We only. Address: PO Box 91701, Washington DC, 20090 USA. (04-Nov-94/BBCM) 11945 **Free Radio Voice of Ethiopian Unity** (t) 1600 flute IS and talk in Amharic, mixing with VOA. (09-Nov-94/Hans Johnson/JIHAD DX)

CLANDESTINE—ASIA A clandestine station which uses the transmitters of Taiwan's *Central Broadcasting System* (CBS) to broadcast to China has increased its airtime by one hour. **Voice of China** now broadcasts from 0830-0930 on 11940 MHz in addition to its usual 2100-2200 transmission on 15280. (23-Oct-94/RJ MEDIA ROUNDUP/BBCM)

Voice of the People, from N to S Korea, now using 3912 (ex 6600) for 2000-2200 broadcast. (Wolfgang Buschel via Mathias Kropf—GERMANY)

CLANDESTINE—MIDEAST *Radio Message of Freedom*, which broadcasts in support of the Hezb-e Eslami (Islamic Party) of Afghanistan led by Golbodin Hekmatyar, continues to be heard at 0730-0830 with programming in Pashto and Dari on 7090 kHz. The radio also announces that it broadcasts at 0230. (BBCM)

Voice of Iranian Kordestan, the radio of the Kordestan Democratic Party of Iran, announced a new schedule from 23rd October: 0900-1000 Kurdish, 1530-1630 Kurdish, 1630-1700 Persian, 1000-1030 Persian, and 0330-0430 Kurdish. Station is currently heard on 4280v kHz. (20-Oct94/BBCM)

CLANDESTINE—NORTH AMERICA *La Voz del CID* observed with religious program of Miami Catholic Church towards Cuba at 0340 on new variable 9920.8 kHz (ex 9942v). Scheduled at 2100(Sun 1200)-0430 UTC on 30m band, 0430-0705 on 6305v

kHz. (Wolfgang Buschel via Mathias Kropf—GERMANY)

CROATIA *Croatian Radio* 24 hours 13830 0700-1600 5920 1230-2100 7370 13640 1600-0700 5895 2100-1230 7370 9830 (ADDX/Shortwave News/Ben Krepp/JIHAD DX)

CYPRUS W94 sked for *Cyprus Broadcasting Corporation* via BBC: 2215-2245 on 6180 7125 9635, Fr/Sa/Su only in Greek. (November ADXN/Bob Padula)

DOMINICAN REPUBLIC *Radio Quisqueya* 6235 React 2205 Great merengue music almost non-stop; full ID by OM with frequency and location ("...desde la ciudad de Puerto Plata...") at 2208. Thanks Berg (Ben Krepp 11-12/JIHAD DX)

ECUADOR *HCJB* Schedule 01-Nov-94 to 01-Mar-95:

0000-0030	French	12005	ECan
0000-0030	German	15250	SAM
0000-2400	Various	17490U 21455U	
0030-0230	Portuguese	15295	SAM
0030-0430	English	9745 12005	NAM
0115-0130	Tajik	6205 11735	CAS
0130-0147	Uzbek	6205 11735	CAS (Su-Th)
0130-0200	Spanish	11910	N/SAM (Fr/Sa)
0147-0200	Russian	6205 11735	CRus (Su-Th)
0200-0400	Russian	6205 11735	CRus
0200-0504	Spanish	3220 6080	Ecu
0400-0430	Russian	6205 11735	WRus (Fr/Sa)
0400-0430	Georgian	6205 11735	Georgia (Su-Thu)
0430-0500	Japanese	9745 11925	N/SAM
0430-0500	German	6205 11735	Eur
0430-0500	English	12005	NAM
0500-0515	Kikongo	9765	SWAf (M-F)
0500-0515	Portuguese	9765	SWAf (Sa/Su)
0500-0530	Czech	6205 9420	Eur
0500-0700	Russian	9445	WRus
0500-0700	English	9745	NAM
0515-0600	Portuguese	9765	SWAf (M-F)
0530-0600	Nordic	6205 9420	Eur (We/Fr/Sa)
0530-0600	Portuguese	6205 9420	Eur (Su/M/Tu/Th)
0600-0630	German	6205 9420	Eur
0600-0700	Russian	12005	WRus
0630-0700	French	6205 9420	Eur
0700-0830	English	6205 9420	Eur
0700-1030	English	6135 9745	SPac

0730-0930	Portuguese	6125 9765	SAM	1100-1300	Arabic	12050 11785 9800
0830-1430	Quichua	3220 6080	Ecu	1300-1500	Arabic	17670 12050 11785 11665
0900-0930	Quichua	6110 9670	SAM			9850 9800
0930-1000	German	6110 9670	SAM	1500-1800	Arabic	12050 9850 9800
0930-1030	Portuguese	6125 9765	SAM	1800-1900	Arabic	12050 9850 9800 9670
1000-1100	Quichua	6110 9670	SAM	1900-2400	Arabic	12050 9850 9800
1030-0504	Spanish	6050	Andes			
1030-1130	English	6135	SPac	<i>Radio Cairo</i>		
1030-1130	Russian	9445	ERus	0030-0430	Arabic	9900
1030-1300	Spanish	11960	SAM	0045-0200	Spanish	11715 9740 9475
1030-1500	Spanish	9765	Amer	0200-0330	English	9475
1100-1430	English	15115	N/SAM	1100-1130	Arabic	17800
1100-1430	English	12005	Carib	1115-1215	Arabic	17745
1130-1200	Japanese	9745 11845	Japan	1115-1215	Thai	17770
1200-1300	Spanish	11910	N/SAM	1215-1330	English	17595
1300-2030	Spanish	15250	SAM	1215-1315	Malay	17770
1430-1600	English	15115	SAM	1320-1450	Indonesian	17770
1430-2100	English	6080	Ecu	1330-1430	Bengali	17595
1500-0504	Spanish	15140	Amer	1330-1530	Persian	11560
1500-1800	Portuguese	15295 17790	SAM	1400-1700	Arabic	15220
1700-2000	English	15490	Eur	1500-1600	Hindi	17690
1800-1830	Czech	15270 17790	Eur	1500-1600	Pashto	17710
1830-1900	German	15270 17790	Eur	1530-1630	Afar	15155
1900-2000	Arabic	15270 17790	NAf	1530-1730	Swahili	11975
2000-2030	Portuguese	15270 17790	Eur (Su/ M/Tu/Th)	1530-1630	Uzbek	9620
			Eur (We/ Fr/Sa)	1600-1800	Turkish	6230
2000-2030	Nordic	15270 17790	SAM	1600-1800	Urdu	17690
			Eur	1600-1645	Zulu	11875
2030-0500	Spanish	11960	SAM	1630-1830	English	15255
2030-2100	French	15270 17790	Eur	1630-1730	Somali	15155
2100-0200	Quichua	6080 3220	Ecu	1645-1730	Shona	11875
2100-2130	German	11835	Eur	1700-1800	Albanian	9950
2130-2200	Arabic	11835	NAf	1730-1900	Amharic	15155
2200-0030	Quichua	9745	SAM	1730-1815	Ndebele	11875
2200-2300	Portuguese	15355	SAM	1800-1900	Italian	9900
2200-2300	Japanese	15295	SAM	1830-1915	Lingala	15255
2200-2300	Spanish	11835	Eur	1830-1930	Wolof	15375
2230-2300	Russian	15250	N/SAM	1900-2000	German	9900
2300-2330	German	15250	SAM	1900-2100	Hausa	15210
2330-2400	German	15250	SAM	1930-2030	Bambara	15375
2300-0030	Portuguese	15295 15355	SAM	1930-2030	Fulani	17840
				2000-2200	Arabic	11990
				2000-2115	French	9900
				2030-2200	English	15375
				2030-2230	French	15335
				2100-2200	Yoruba	15210
				2115-2245	English	9900
				2215-2330	Portuguese	15420
				2300-0030	English	9900
				2345-0045	Arabic	17770 15220
				(11-Nov-94/BBCM)		

*from Radio Transmundial (15-Nov-94/Rich McVicar—HCJB)

HCJB will stage another mediumwave DX test this month. Look for them on 690 kHz, UTC December 24, 1994 from 0515 to 0545 UTC. (Rich McVicar—HCJB)

EGYPT Latest external sces skeds from Cairo:

Arab Republic of Egypt Radio (General Program)

0200-0350	Arabic	12050
0350-0700	Arabic	12050 9800 9770
0700-1100	Arabic	15115 12050 11785 11665 9850 9800

ERITREA Voice of the Broad Masses of Eritrea has discontinued its broadcasts in Amharic. (BBCM)

**FRANCE Radio France Internationale schedule 25
Sept 1994-25 March 1995:**

0000-0030	French	5920 5945 7120 9715 9790 9800 12045 15440	1130-1200	French	6175 9650 9805 11670 11700 11845 15155 15195 15300 15315 15365 15435 15605 17620 17650 17850 21520 21580 21620
0030-0100	French	5920 5945 7120 9715 9790 9800 12045	1130-1200	Spanish	11670 15515 15435
0000-0100	Portuguese	11995 13625 15200	1200-1230	French	6175 9790 11670 11700 11845 15300 15315 15435 15515 17620 17650 17850 21580 21620 21685
0100-0200	French	3965 5945 9715 9790 11600	1200-1300	Cambodian	7305
0100-0200	Spanish	5920 9800 11995	1200-1300	English	9805 11615 13625 15155 15195 15325 15365
0200-0300	French	3965 5920 5945 9715 9800	1200-1300	Mandarin	7140
0300-0400	French	3965 5945 5990 6045 7135 7280 7315 9790 9800	1230-1300	French	6175 9790 11670 11700 11845 15300 15315 15435 15515 17620 17650 17850 21580 21620 21685
0400-0500	French	3965 4890 5920 5925 5945 5990 6045 7135 7280 7315 9790 9800 9805	1300-1330	French	6175 9790 9805 11670 11845 13625 15155 15195 15300 15315 15365 15515 17620 17650 17850 21580 21620 21685
0500-0545	French	3965 4890 5925 5990 6045 6175 7135 7280 9550 9790 9805 11685 11700 11995	1300-1330	Spanish	15435 17560 17860
0500-0600	Spanish	5920 9800	1330-1400	French	6175 9790 9805 11670 11845 13625 15155 15195 15300 15315 15365 15435 15515 17560 17620 17650 17850 17860 21580 21620 21685
0545-0600	French	3965 4890 5925 6045 6175 7135 7280 9550 9790 9805 11685 11700 11995	1400-1430	Spanish	17860 21645
0545-0600	Polish	5990	1400-1500	English	7110 12030 17560
0600-0700	French	3965 5925 5990 6045 6175 7135 7280 9550 9745 9790 9805 9845 11685 11700 11995 15135 15155	1400-1500	French	6175 11615 15155 15195 15315 15365 15605 17575 17620 17795 17850 21580 21620
0700-0800	French	3965 6175 7135 7280 7305 9745 9790 9805 11670 11685 11700 11790 15155 15300 15315 17620 17800 21620	1400-1500	Russian	9805 11670
0800-0900	French	3965 6175 9790 9805 11670 11790 11845 15155 15195 15300 15315 15605 17620 17650 17850 21620	1430-1500	Creole	17860 21645
0900-1000	French	6175 9805 11670 11845 15155 15195 15300 15315 15605 17620 17650 17850 21580 21620	1430-1530	Viet.	6120
0930-1030	Mandarin	9650	1500-1600	French	6175 9495 9605 9790 11615 11845 11995 15300 15460 17575 17795 17850 17860 21620 21645
1000-1030	Spanish	5920 9790	1500-1600	Serbo-Croat	7135 9805
1000-1030	French	6175 9805 11670 11845 15155 15195 15300 15315 15605 17620 17650 17850 21580 21620	1600-1700	Arabic	9845
1030-1100	French	6175 9650 9790 9805 11670 11700 11845 13625 15155 15195 15300 15315 15605 17620 17650 17850 21580 21620	1600-1700	English	6175 9485 11615 11700 12015 15530
1100-1130	French	6175 9650 9790 9805 11670 11700 11845 13625 15155 15195 15300 15315 15435 15605 17620 17650 17850 21520 21580 21620	1600-1700	French	3965 9495 9605 9790 11965 11995 15300 17620 17630
1100-1200	Laotian	7305	1600-1700	Romanian	7135 9805
			1700-1800	Arabic	7325 7335 9655 9845
			1700-1800	French	3965 6175 9495 9605 9790 11705 11965 11995 15300 17620 17630
			1700-1800	Polish	5900 7135
			1700-1800	Portuguese	12015

1800-1830	French	3965 5900 6175 7135 7160 7315 9485 9605 9790 11705 11965 15300
1800-1900	German	6150 7145
1800-1900	Persian	5925 7335
1830-1900	French	3965 5900 6175 7135 7160 7315 9485 9605 9790 11705 11965 15300
1900-2000	French	3965 6175 7135 7160 7315 9485 9790 11705 11965 15300 21785
1900-2000	Russian	5900 7335
2000-2100	French	3965 5915 6175 7160 7315 9485 9790 15300 21765
2000-2100	Serbo-Croat	5900 7135
2100-2200	French	3965 5915 5945 6175 7160 7315 9790 15300 21765
2130-2200	Romanian	5900 7135
2200-2300	French	3965 5920 5945 9715 9790 9800 13640
2200-2300	Polish	6175 7135
2200-2300	Portuguese	11995 15200 17620
2200-2300	Spanish	5940
2300-2400	French	3965 5945 7120 9565 9715 9790 12045
2300-0000	Spanish	9800 11995

(28-Oct-94/Frederick Gordts—BELGIUM/SW ECHO)

GERMANY 6005 *Shortwave Berlin* will be closed soon. So hurry up, to get a QSL card. (09Nov-94/Juergen Kubiak—GERMANY/SW ECHO)

GUATEMALA 4780, *R. Cultural Coatan*, now noted on this frequency, signing on at 1100. Partial ID copied is: "TG--, Radio Cultural Coatan, 4780 kHz onda corta, banda de 60 metros...desde San Sebastian Coatan, Huehuetenango, Republica de Guatemala, Centroamerica" Guitar ballads and talks in Indian dialects were heard. (Berg NU #1294)

HONDURAS *Radio Luz y Vida* 3250 reactivated after lengthy time off of shortwave. It was heard here in Iowa on November 13 & 14 UTC between about 0130 to 0330+. Signals were strong. (Don Moore/Hans Johnson/JIHAD DX)

INDIA *AIR Panaji-Goa* heard in Bangkok last couple of weeks on 4775 between 1400 and 1600 with *AIR* programs, including English news to 1445, commentaries, other music and misc programs in language, clear "*Akashvani Panaji*" ID (they add another syllable to make it Pana-gahji). (06-Nov-94/Dan Robinson—THAILAND)

AIR Thiruvananthapuram 5010 Finally figured out the id for this one, I believe. The town name seems to be shortened to Thirupuram; on 18-Nov at 0026 I heard an id that sounded like "*Akashvani Thirupuram*," English news from 0035-0040 plus lots of great music. (Hans Johnson/JIHAD DX) Excellent reception [in Finland], so must be a 10-50 kW transmitter. (06Nov-94/Jorma Mantyla—FINLAND)

Recently logged on ECNA are 3315 *AIR Bhopal* (@1145), 3323 *AIR Simla* (@0110) [active since 06-Nov], 3365 *AIR Delhi* (@0140), 4920 *AIR Madras* (@0130, 1145), 10330 *AIR Madras* (@0210) (15-Nov-94/Chuck Rippel)

The latest sked for *AIR*:

0000-0045	Tamil	13700 11620 9910 9550
0015-0430	Urdu	6155
0100-0130	Burmese	15325 11880 9950
0100-0200	Sindhi	7125 5990
0130-0200	Tibetan	15325 11880 9950
0130-0228	Nepalese	9550 7210 6045 3945
0215-0300	Pashto	11910 9910 7225
0300-0345	Dari	11910 9910 7225
0315-0415	Hindi	17387 15165 15075
0400-0430	Persian	17805 15050 11730
0415-0430	Gujarati	17387 15075
0430-0530	Arabic	17785 15050
0430-0530	Swahili	17387 15075
0700-0800	Nepalese	11735 9610 7250
0830-1130	Urdu	11620 9675
0845-0945	Indonesian	17387 15050
1000-1100	English	17895 17387 15180 15050
1115-1200	Thai	17830 15365 11715
1115-1215	Tamil	17865 15770 15335 15075 13750
1145-1315	Chinese-std	17705 15050 11735
1215-1245	Telugu	17387 15335 13750
1215-1315	Burmese	11715 10330
1215-1330	Tibetan	9565 7412
1230-1500	Sindhi	11620 6165
1300-1500	Sinhala	15020 9700
1315-1430	Dari	9910 7140
1330-1430	Nepalese	7412 6045 4860 3945
1330-1500	English	15120 13732
1415-1530	Pashto	9910 7140
1430-1930	Urdu	6045 4860
1500-1600	Baluchi	11620 6165
1515-1600	Gujarati	15120 11805
1515-1615	Swahili	15075 9950
1530-1545	English	11670 9910 7412 7140 (ry domestic nx)
1615-1715	Russian	15140 11620
1615-1730	Hindi	15075 11620 9950 7412
1615-1730	Persian	11935 9910 7265
1730-1945	Arabic	15185 9910
1745-1945	English	15075 13750 11935 11620 9950
1945-2030	French	15185 11860 9910
1945-2045	Hindi	11620 9950 7412
2045-2230	English	15225 11715 11620 9950 9910 7412
2245-0045	English	15145 13750 11745 9950 9705
2300-2400	Hindi	15165 11620 9950

In the past, *AIR* has also broadcast an additional service in Urdu during the Hajj (pilgrimage) season, from 0530-0600 on 17785 and 15135 kHz. *DXers Corner*, a ten-minute program, is presented on the 2nd and 4th Monday of each month at 1040, 1435, 1840, 2130. (04-Nov-94/BBCM/additional info from Tom Sundstrom)

IRAN VOIRI has transmissions in English to America at 0030-0125 on 9022, 7110 and 11790 (ann.) kHz, in French to Canada at 2230-2325 on 9022, 11790 and 11965 (ann.) kHz and in French to Europe at 0630-0730 on 11745, 11790, 15260. (29-Oct-94/RVT's RADIO WORLD/Cees van Oudheusden—NETHERLANDS/SW ECHO)

ISRAEL Found on the SW ECHO: "Please read the below message and write or fax to the appropriate people so that we can keep *Kol Israel* alive on shortwave! Kol Israel's fax is 972-2302-327, address is Kol Israel POB 1082 Jerusalem, Israel. Kol Israel tells people to write to the government. Shulamit Aloni is the Communications director—but at this point I don't have her address. I'll post it once I get it.... Maybe you could just address it to her in Jerusalem.... The closure would be for ALL SHORT-WAVE broadcasts Hopefully if enough of use write they'll find alternative funding.

*Date: Mon, 14 Nov 94 01:06:16 EST

*Subject: Israel radio and WRN

*Daniel,

*Thanks for your message.

*We will immediately change 7490 to 7495 and 11585 to 11588 kHz.

*Bezeq say they have not got your latest fax, and I would be interested to know the time when 11585 is poor.

*According to information I received today, the Jan 1 deadline is to be kept to. The Director General feels the Government (like other governments) should finance overseas transmission- he will make the programs. I tend to agree with him that the domestic TV license is not really for this purpose. So I would protest to Minister of Communications—Shulamit Aloni.

*I have several interests and have looked after monitoring and frequency advice for Bezeq since 1978, but co-founded WRN three years ago to offer stations new delivery options. I believe diverse delivery methods are inevitable. Short wave certainly has its strengths but for reliable, high quality reception capable of local relay satellite is the way forward. Portability is not such a big issue as most shortwave listeners have fixed installations at home.

*We are planning to offer live WRN and news cuts on Internet very soon via the Multicast service (also known as Internet Talk Radio) based in Washington.

"Please keep in touch.

"Best Regards,

"Jeff Cohen"

(14-Nov-94/Daniel Rosenzweig/SW ECHO)

JORDAN Radio Jordan, noted at 1500 in English on 8655 (poor) and 9560 with good signal while in Greece. (Krone NU#1294)

LAOS 6129.92 Lao National Radio noted @1220 (09-Nov-94/Chuck Rippel)

LIBERIA Liberia Broadcasting System (ELBC) is sked from 0550-1001 and 1355-1730 on 7275. (04-Nov-94/BBCM)

MALAYSIA Voice Of Malaysia, 9750, 1205-1230, station ID as "Suara Malaysia" Female announcer w/ program of Malaysian pop ballads. Another ID at 1230. Fair signal surrounded by co-channel QRM. (Ort, NU #1295)

MONGOLIA Radio Ulan Bator English 0910-0940 Daily 12000 7290 plus Mon Wed 1200-1230 Thu Sat 1200-1230 Daily 1445-1515. Fri Sat Sun 0330-0400. 1930-2000 Daily 13650 7290 Tue Wed 0300-0330 12015 7290. Mongolia, not UTC days. (Andreas Volk via Ben Krepp/JIHAD DX)

MOROCCO Radio-TV Marocaine heard with their English program from 1400 to 1447 on 17595 kHz. "Welcome to the International Service of Radio Morocco". Pop music and talk features. Fair signal. (D'Angelo, NU #1294)

MOZAMBIQUE Updating last month's LN, here are the latest skeds for *Voz da Renamo* and *Voz do Sonho*:

Voz da Renamo languages include Portuguese, Tsonga, Lomwe and Macua 1000-2000 Multilingual 7135 6030-announced (Signoff unconfirmed)

Voz do Sonho

0500-0700 Multilingual 6175-announced 6100
1400-1800 Multilingual 6100

(04-Nov-94/BBCM)

NEPAL Radio Nepal, 7165, Noted at 1118 with talk by man, ID as "Yo Radio Nepal Ho" at 1120. (Johnson 10-30, NU #1296)

NIGERIA Radio Nigeria-Lagos sked:

0425-1000 English 4990 3326
1000-1700 English 7285 4990
1700-2305 English 4990 3326

National news (Channel 1) bulletins at 0600, 1500 and 2100. (11-Nov-94/BBCM)

NORWAY Radio Norway has made a few frequency changes: 1300 on 13800 (ex 11730) and 15605 kHz

(ex 15190), 2100 on 9590 kHz (ex 6015), 2200 on 5905 kHz (ex 6120), 2300 on 6030 kHz (ex 6120) (see also BDXC-bulletin, 11/94). (28-Oct-94/O.M. Grimdalen (R.Norway)/INTERNET)

PAKISTAN Transmissions of *Azad Kashmir Radio* from Muzaffarabad have been extended, now from 0045-0500 and 1000-1808. Both the stations of Azad [Free] Kashmir Radio, i.e. Muzaffarabad and Trarkhal, broadcast an average of 23 hours and 30 minutes daily. Muzaffarabad, with a 110-kW shortwave transmitter [on 7267.3 kHz], covers Azad Kashmir and western parts of Indian-held region, besides Pakistan; while Trarkhal station, with a 10-kW shortwave transmitter [on 3665.1 kHz], covers Indian-held territory and surrounding areas of Bharat and Azad Kashmir. (BBCM)

Azad Kashmir Radio 7267.3 1128 Urdu Id, two anmts, into subcont-style mx @1130. (12-Nov94/AQ)

PARAGUAY AWR's plans for broadcasting to South America include the distribution of programs by satellite and the construction of a new shortwave station, probably in Paraguay. The plans provide for either 50 or 100-kW shortwave transmitters to be installed to cover most of the continent. While three or four transmitters may eventually be required to achieve this, the plans call for an initial facility with only two transmitters. Engineering studies are under way for a location in Paraguay for this newest facility, which it is hoped will start operations before the end of 1995. Government issuance of licenses and frequencies will determine how soon the project can start. (AWR Newsletter)

PERU 4662v *Radio Soledad* heard from 1115-1135 on 06-Nov. presumed to be using old xmtr of Radio Tayabamba. (TIN/RELAMPAGO DX)

5116.4, *Radio Diez*, testing from October 16th from 2300-0100+ from Iquitos, using slogan "Yo soy La Voz Del Campo". (Klemetz, PlayDX 810)

5235.38 *Radio Apurimac* heard in late October from 1034-1100 with morning pgm, "Amanecer Andino." S/on is around 0950-1000 weekdays. (TIN/RELAMPAGO DX)

8324.1, *Radio Emisora Alfa*, first reported as an UNID by Rich McVicar in August, was noted signing off around 0100, tentatively xmitting from Tingo Maria in Peru. (Klemetz, PlayDX #810)

Radio Naylamp in Lambayeque has been off shortwave for a couple of months now, according to Dr. Juan Jose Grandez Vargas, the Director-Gerente of the station. They operate on 4300 kHz and use the slogan "La Diferente". Their address is: Av. Huamachuco 1080, 2do Piso Lambayeque, Depto. de La Libertad. (TIN, NU #1294)

PORTUGAL *Radio Renascenca* sked, all broadcasts in Portuguese:

0015-0115	9600	
0400-0600	6100	M-F
0945-1100	9575	Su
1300-1700	9680	Sa/Su
1700-1900	9680	

(11-Nov-94/BBCM)

QATAR *Qatar Broadcasting Service*, 9750 New Frequency, Man and woman announcers in Arabic, with mx bridges 1920-2004. Six pips and ID noted at 2000. (Orr 10-28, NU #1296)

SAUDI ARABIA BSKSA sked:

0300-0600	Holy Quran	9730 9555
0400-0500	Somali	15335
0400-0600	Turkish	15060
0500-0600	Swahili	17760
0900-1200	Holy Quran	21495 17880
1000-1200	Indonesian	21665
1200-1600	Holy Quran	15280 15165
1200-1400	Urdu	15345
1400-1500	Bengali	15345
1400-1600	Persian	11825
1500-1600	Turkmen	9730
1600-1700	Bambara	17775
1600-1800	Holy Quran	11920 11835 9730
1800-2100	Holy Quran	11935

(18-Nov-94/BBCM)

SINGAPORE 4900nf *SBC*, 1010-1035 and 1110-1132, in CC with ID as "Singapore guangbo diaitai," //6000 (07-Nov-94/Tony Orr/JIHAD DX)

SPAIN *Radio Exterior de España* in English:

0000-0200	9540	N. America
0500-0600	9540	N. America
1900-2000	9675	Africa
2100-2200	6125	Europe

(21-Nov-94/Brian Johnson/SW ECHO)

SWEDEN *Radio Sweden* replaced its 31-mb frequency with new 7120 for their 0230 and 0330 transmissions. (15-Nov-94/Lou Josephs)

THAILAND *Radio Thailand* via Udorn Thani relay station:

0000-0030	English	9680	Asia/Africa
0030-0100	English	11905	ECNA
0100-0200	Thai	11905	ECNA
0300-0330	English	11890	WCNA
0330-0430	Thai	11890	WCNA
1100-1115	Vietnamese	7285	Asia
1115-1130	Khmer	7285	Asia
1130-1145	Laotian	6040	Asia

1145-1200	Burmese	6040	Asia
1200-1215	Bahasa Malay	11805	Asia
1215-1230	Bahasa Indo.	11805	Asia
1300-1315	Japanese	7105	Asia
1315-1330	Mandarin	7105	Asia
1330-1400	Thai	7105	Asia
1800-1900	Thai	11855	Africa/ME
1900-2000	English	9655	Europe
2000-2015	German	9655	Europe
2015-2030	French	11835	Europe
2030-2045	English	11835	Europe
2045-2115	Thai	11835	Europe

(Direct/Jerry Klinck + 31-Oct-94/Juergen Kubiak-GERMANY/SW ECHO)

Radio Thailand [non-Udorn] broadcasts to Asia on 9655Khz and 11905Khz. The English broadcasts are on from 2300-0430, which is followed by a half-hour French transmission, and then another full hour of English language broadcast. There is a mixed language transmission starting from 0915 hrs to 1500 hrs. (06-Nov-94/Ethan Benjamin Randall SINGAPORE/INTERNET)

USA Gene Scott announced **KAIJ** in Dallas has added a second transmitter he has rented 24 hours, 7 days. The announced frequency was 13815, and he said its forward lobe is toward Japan from Dallas. No other frequencies or times were announced. (06-Nov-94/Don Kimberlin/SW ECHO) 13815 will be used for daytime, switching to 5810 at night. (BBCM)

Dave Valko, Kris Field and Hans Johnson paid **WMLK** Bethel a visit on October 28th. Although we arrived unannounced, the engineer who built the station showed us around. They use reel to reel decks but don't have a microphone because "one of the guys was talking stupid" years ago. The whole station has a home-built look and was rather primitive. They are right next to the interstate just outside of Bethel, PA. Future plans call for a new antenna and a 100 kw transmitter. (Johnson, NU #1296)

WRMJ's schedule effective 7th November 1994. All on 9955 kHz:

0030-0300	English	Mo	
0100-0130	English	Tu-Su	"Viva Miami"
0130-0500	Spanish	Tu-Su	"Viva Miami"
1100-1200	Spanish	Su	
1100-1400	Spanish	Mo-Sa	
1200-1400	English	Su	
1400-1500	English		
1900-1930	German	Su	
1900-2000	English	Sa	
1930-2000	English	Su	
2230-2330	English	Sa	
2300-0100	English/ French	Mo-Fr	
2330-0100	Spanish	Sa	

(11-Nov-94/BBCM)

WWCR sked:

0000-0900	English-1	7435
0100-1400	English-2*	5935
1100-0000	English-1	15685
1200-1400	English-3	5065
1400-0100	English-2*	13845
1700-2100	English-3	17525
2100-2300	English-3	12160
2300-0900	English-3	5065

* Dr. Gene Scott—University Network (11-Nov-94/BBCM)

These brief quotes were taken from a op-ed page column of Georgie Anne Geyer published in the 10 Nov 94 The Houston Post. They concern **Radio Marti** and **Radio Caiman**:

"...officials have this fall quietly cut back Radio Marti broadcasts to Cuba from 100 kilowatts of power, which can reach the entire island, to 50, which Castro can easily jam. Spokesmen for Cuban freedom, such as former Cuban Air Force Gen. Rafael del Pino, the island's highest-ranking military defector, have been stopped from speaking on Radio Marti, and a CIA radio, 'Radio Caiman' from Costa Rica, has now been closed...." (10-Nov-94/Jeff Haverlah/SW ECHO) This is interesting. Everyone always thought that Caiman was in Guatemala. So that is why I have not been hearing Caiman the last three weeks. This is the first time I can recall someone's name associated with Caiman. (13-Nov-94/Ulis Fleming/SW ECHO)

As of 30-October, **VOA** dropped all broadcasts in Armenian, Estonian and Lithuanian. (BBCM)

With practically no prior notice, **VOA Bethany** closed down for good on Sunday, 13 November. The final transmission, **Radio Marti** on 11740 and 11815, ended at 1800 UTC. Beginning 14 Nov, one frequency went to Greenville, the other to Delano. (Dan Ferguson) [With such little advance notice, I doubt many SWLs got to log the final broadcast for Vodenik's special QSL card. Looks suspiciously as if the powers-that-be planned it that way. Surely VOA could've better trimmed its budget by eliminating several layers of middle management than by trimming its own on-air output. A fellow on CompuServe overheard two locals at the Bethany McDonalds discussing the closure. One said the government was either going to bank the land, sell it for housing development, or give it to local government for use as a park. The other genius said he wasn't sure about the land as it may contain radiation from all those years of broadcasting!-AQ]

YUGOSLAVIA Radio Yugoslavia schedule effective 30th October 1994 to 26th March 1995. All of Radio Yugoslavia's shortwave transmissions now emanate from transmitters at Bijeljina in northeast Bosnia-Herzegovina. These transmitters also carry

broadcasts from Serb Republic Radio.

0000-0030	Spanish	11835 9720
0030-0130	Serbian	6195 Su
0030-0100	Serbian	6195 Mo-Sa
0100-0130	English	6195 Mo-Sa
0130-0200	Serbian*	6195
0200-0230	English	6195
1330-1400	English	11865
1400-1430	Serbian*	11835
1530-1600	Arabic	15175 11800
1600-1630	Russian	11755 6005
1630-1645	Bulgarian	6100 Mo-Fr
1700-1730	French	15175 6100
1730-1800	German	7215 6100
1800-1815	Albanian	6100 Mo-Fr
1830-1845	Hungarian	6100 Mo-Fr
1845-1900	Greek	6100 Mo-Fr
1900-1930	Russian	7165 6005
1930-2000	English	9720 6100
2000-2030	Spanish	7220 6100
2030-2100	Serbian	9595 6100 Su-Fr
2030-2130	Serbian	6100 Su-Fr
2030-2130	Serbian	9595 6100 Sa
2100-2130	German	6100 Su-Fr
2130-2200	French	6100
2200-2230	English	6185 6100

*relay of Radio Belgrade First Program (18-Nov-94/BBCM)

ZIMBABWE ZBC plans a return to shortwave to improve domestic and regional coverage. Finnish DXer Jorma Mantyla noted Zimbabwe back on shortwave on 19-Nov only. Frequency was 3396 kHz, time 1959 UTC. He suggests checking old Zimbabwe-frequencies (3306, 3396, 4828 etc.) (/17-Nov-94/RN MEDIA NETWORK/INTERNET/22-Nov-94/Chuck Rippe). BBCM reports 3306 was heard testing.

UNIDENTIFIED 4775 UNID 1157 vocals, too weak talk and strange chants. Didn't sound sub-cont though. (07-Nov-94/Hans Johnson/JIHAD DX)

UNID ARAB 10000 @2025 w/Qur'an chants atop WWV, nulled off back of beverage. Still there @2130. (11/14 Chuck Rippe DXpedition, Cape Hatteras, NC)

DX PROGRAMS

USA AWR Worldscan is a new DX show produced by Adrian Peterson is to start over **KSDA**, **TIAWR**, **WRMI**, & **TGMU** on January 1; for **HRJA**, it will be Jan 8; and for **AWR-Europe** it will be January 15. A specially endorsed QSL card will be available for all reception reports dated January, February, or March 1995. These reports should be sent, with appropriate return postage where possible, to: Worldscan, Box 29235, Indianapolis 46229, USA.

The tentative schedule for the new program is as follows:

Sat 0100	9955	WRMI
Sat 1515	9370	KSDA
Sat 2000	15695	HJRA
Sun 0900	9450	AWR-Slovakia 305
Sun 1500	9370	KSDA
Sun 2100+	6055	AWR-Slovakia 305
Sun 2315	11980	KSDA

(13-Nov-94/Ben Krepp/JIHAD DX)

PIRATES—EUROPE SRS NEWS is a weekly newsletter of loggings and info on Europirates. From that newsletter comes this list of Europirates logged during November. Loggings have been edited by me [AQ], with unidentified stations and others broadcasting at impossible-to-NA times deleted. These stations operate only on weekends.

3899	0945	<i>R. Moonlight</i>	EE/DD
3910	1107	<i>R. Jimmy</i>	DD
3912	2323	<i>International Music R.</i>	EE
3913	0001	<i>R. Moonlight</i>	EE/DD
6200	1012	<i>Britain's Better Mx Stn.</i>	EE
6206.5	0930	<i>Dino R.</i>	GG
6206.5	0930	<i>R. Nord</i>	SW
6212.5	0900	<i>R. Dr. Tim</i>	GG/EE/SW
6232	0915	<i>R. Speranza</i>	gospel mx
6235	0900	<i>Jolly Roger R.</i>	EE
6255	0945	<i>R. East Coast Commercial</i>	EE
6260	0915	<i>Welle Wahnsinn/ Crazy Wave</i>	GG/EE
6280	1035	<i>R. Mirage</i>	EE/DD
6282	0936	<i>Star Club R.</i>	GG
6282	0915	<i>R. Popcorn</i>	GG
6290	0917	<i>Overflow R. Int'l.</i>	EE
6298	0946	<i>Trans Atlantic R./ YBC</i>	EE
6299	1009	<i>R. Blackbeard</i>	E
6300	0831	<i>R. Pamela</i>	EE
6300	1025	<i>Ozone R. Int'l.</i>	EE
6399	1025	<i>West+North Kent R.</i>	EE
6399	0828	<i>Angel R. International</i>	EE
6399	0735	<i>Optimod</i>	EE
6915.5	0830	<i>R. Dublin</i>	EE
7294U	0920	<i>R. Europe</i>	II
7294U	0940	<i>R. Marabu</i>	EE
7294U	0840	<i>Onda Caliente</i>	EE/FF/GG
7294U	0805	<i>Sunshine R. Classic Rock</i>	EE/GG
7361	0802	<i>R. 101</i>	GG/EE
7385	1024	<i>International Music R.</i>	DD/EE

7414 0910 *R. Mirage* EE
 7418 0905 *Heavy Dude R.* EE
 7473 0910 *Onda Caliente* EE/FF, via
 R.Waves

(Nov-94/SRS News/Jonny Augustsson—SWEDEN)

Sad news from Germany: This Sunday [13-Nov] the *Radio Popcorn/Star Club Radio* co-site operation were raided by the German GPO officials while transmitting on 6282 kHz. At 1015 UTC the equipment was confiscated and at least one operator was tracked down at the transmitting site. The unlucky guys learned that the GPO had located several further German Shortwave pirates recently with their directional radio control systems. Now it seems that the German Free Radio season has been terminated until further notice! (15-Nov-94/Jonny Augustsson—SWEDEN)

Next transmissions of *Radio Marabu* via the IRRS, 7125 kHz are as follows: December 10th, 1200-1400 UTC, repetition December 16th, 1800-2000 UTC (15-Nov-94/Jonny Augustsson—SWEDEN)

Radio Fan Man is a new station that may pop up soon via the Radio Europe outlet from Italy, 7294 kHz, USB mode. Address is the Wuppertal drop box. (15-Nov-94/Jonny Augustsson—SWEDEN)

PIRATES—NORTH AMERICA *Voice of Scotland's* test transmission to North America on October 1st was indeed a hoax! After talking with reliable sources in the know, it can be said that the broadcast did originate from North America, mostly likely in the central section. So, if you get your QSL for this one, list it as North America. (Lobdell) [Told ya!-AQ]

This month we spotlight the *North American Pirate Relay Service* (NAPRS), just over two years old and probably one of the most active pirates today. The operator calls himself Richard T. Pistek, the actual name of a Chicago area DXer who took his own life in the late 70s. NAPRS has relayed a number of Europirates and domestic stations including Radio Azteca. If you hear a NAPRS relay, reports are promptly QSLed by writing to Box 452, Wellsville, NY 14895. (Lobdell) To have your pirate profile listed here, send it to Chris Lobdell. [Will they get extra-prompt service if they include a crisp new twenty, Chris?-AQ]

PIRATES—SOUTH AMERICA According to a report in PIRATE CONNECTION #9 (A Swedish based publication), Jorge Garcia of *Radio Pirana International* will travel to Argentina in December. He's planning on using a new 120-150 transmitter while there. Possible frequencies to watch are 13950, 15030 or 48 meters. (Campbell, NU #1291)

PLEASE GO AWAY George Otis of High Adventure Ministries will conduct his next tour of the Holy Land from 13 to 23 February. The trip will include a visit to the Voice of Hope at Metulla. More info by calling 805-520-9640 or by writing High Adventure Tours, PO Box 100, Simi Valley, CA 93062. HCJB is another broadcaster that conducts tours. Address for these trips to Ecuador, usually several times a year, in PO Box 39800, Colorado Springs, CO 80949-9800. (Marlin A. Field)

FILE UNDER "EH?"

MY CUTIE WENT QRT, SO NOW I'M DANCIN' WITH MY DUMMY LOAD Andrew Huddleston, G3WZZ, and his wife Lissa Ladefoged have produced an album of songs written especially for and about radio amateurs. Titles on the new album include "Always on the Air," "On the Monday Evening Gray Line," "It's Great to QSO in Morse Again," and "Out In To The Wild Blue Yonder," the latter a tribute to DXpeditioners. The name of the album is SEEK YOU. (20-Oct94/Amateur Radio Newline/Steve Coletti)

AND SPEAKING OF SONGS, here's one Ye Olde Ed wrote just for you:

God rest ye merry DX fiends, and dabblers alike

Let's hope the coming days will bring cool loggings down the pike

We pray that somehow YFR will spend the year on strike

Oh St. Nick, won't you bring a shiny toy—to this old boy

Oh tidings of Watkins-Johnson joy!

Happy holidays and best wishes for a healthy and prosperous 1995 to you all!

FOR SALE: Customized Beam Headings (from/to) and distances (MI/KM) to over 480 WRTH transmitter sites including new Russian Republics. ITU Country Codes included. Send your location or coordinates, \$6.95. NASWA Journals '91 and '93 complete, \$10.50 a year or \$20.00 for both. WRTH '91, \$7.95 '93, \$8.95. "Passport to World Band Radio" '94, \$8.95. All items include shipping (overseas shipping extra). Cashiers check or money order only, please. Al Drehmann, Route 2, Box 3-B, Tryon, NC 28782. Phone (704) 894-3398. No collect calls, please.

QSL Reports

Sam Barto
47 Prospect Place
Bristol, CT 06010



ABU DHABI: UAE Radio 9770, 11885 and 13605 f/d ltr. w/ schedule in 43 ds. for 1 IRC.(Lane). 13605 same in 99 ds.(Mulrean).
ANTIGUA: BBC Caribbean Relay Station 15220 f/d ltr. in 76 ds.(Berish-PA).

ARMENIA: Radio Mitternachtsruf 11790 via **Radio Intercontinental** f/d "paper" cd. in 18 ds. v/s Jonathan Malgo.(D'Angelo).

ASIATIC RUSSIA: VOA 9845 via **Novosibirsk** f/d * cd. w/ schedule in 59 ds.(Humeny-ONT).

Radio Moscow 15480 and 17720 via **Irkutsk** f/d "Friendship House" cd. in 55 ds.(Humeny). 11665 same cd. in 1 1/2 mo. (Barto-CT). 10300 USB f/d "Arbat Square" cd. w/ schedule in 3 mo.(Barto-CT). 15425 via **Petro-pavlovsk - Kamtchatsky** f/d cd. in 1 1/2 mo.(Barto-CT).

AUSTRALIA: VL8A 2310 via **Alice Springs** f/d ltr. in 352 ds. for 2 IRCs. v/s Rae Allen, Regional Programme Manager. Also rcvd. postcard and sticker.(Com-eau-MA). **VNG** 5000 f/d personal cd. and ltr. in 1 1/2 mo. for a taped rpt. and ms. v/s Dr. Richard Brittain.(Rausch-NJ). **Radio Australia** 15415 f/d ltr. w/ schedule in 58 ds. for 1 IRC.(Mulrean). 17860 f/d ltr. w/ schedule in 78 ds. for 1 IRC.(Lane-ONT).

AUSTRIA: Radio Austria International 9870 f/d ltr. w/ sticker and schedule in 12 ds.(Berish). 9655 f/d folder cd. w/ schedule in 15 ds.(Lane).
BANGLADESH: Radio Bangladesh 4879.2 f/d "Classical Dancer" cd. in 2 mo. w/ schedule.(Barto-CT).
BELGIUM: Radio Vlaanderen International 13675 f/d cd. w/ sticker in 27 ds.(Mulrean). 11740 same in 58 ds.(Warren-NJ).
BOLIVIA: Radio Centenario CP66 4855 f/d prepared cd. w/ ltr. in 27 ds. * w/ sticker for a SP rpt. and \$1.00. v/s Napoleon Ardaya Borja, Director.(D'Angelo-PA). **Radio Libertad CP48** 5005 f/d ltr. in 2 mo. for a SP rpt. v/s Lic. Teresa Sanjines L., Directora.(Barto-CT). **Radio Santa Cruz** 6135 f/d personal ltr. w/ pennant and sticker in 4 mo. for a SP rpt. v/s Yolanda Marco, Secretaria.(Field-MI).

The Voice of the OAS
ORGANIZATION OF AMERICAN STATES



BONNAIRE: Radio Nederlands 6165 f/d "Tulip" cd. w/ sticker in 68 ds.(Berish).
BRASIL: Radio Bras 15445 f/d cd. w/ schedule in 2 mo. for \$1.00. (Dybka-TN). f/d cd. w/ sticker in 9 mo. for \$1.00.(Kohlbrenner-PA).



Radio Singapore International
QSL • Farrer Road PO Box 5330 Singapore 9128

Date 9/5/92

Dear Mr. D'Angelo,

Thank you for your reception report on 9330 kHz from 12-03 UTC to 1240 UTC on 3/2/92 which agrees/does not agree with our schedule.

We hope you will continue to enjoy our programmes.

Radio Singapore International



To
Mr. Richard A. D'Angelo
2216 Burkley Drive,
Wyoissing, PA 19610
USA

*
for a SP rpt. v/s Lic. Teresa Sanjines L., Directora.(Barto-CT). **Radio Santa Cruz** 6135 f/d personal ltr. w/ pennant and sticker in 4 mo. for a SP rpt. v/s Yolanda Marco, Secretaria.(Field-MI).

BONNAIRE: Radio Nederlands 6165 f/d "Tulip" cd. w/ sticker in 68 ds.(Berish).

BRASIL: Radio Bras 15445 f/d cd. w/ schedule in 2 mo. for \$1.00. (Dybka-TN). f/d cd. w/ sticker in 9 mo. for \$1.00.(Kohlbrenner-PA).

Radio INTERNACIONAL



in 6 wks. v/s B. Leite da Costa. (Barto). **Radio**

Guaruja 5980.1 p/d "Joaquina Beach" cd. in 2 mo. for a PT rpt. (Barto-CT). **Radio Difusora**

Maranhao 4755 f/d "Certificate" in EG w/ wrong freq. in 253 ds. for a PT rpt. and \$1.00. v/s Jose de Arimatela Araujo, Dir-

NOTES: **Mary Jo Ondrechen** is back from her sabbatical and is settled in with her R8 and 300 foot longwire antenna. This is strung around the attic of the condo unit! I won't tell the management...Sam. **David Berish** is a new reporter and has been a member for about a year. Dave also uses an R8 and Alpha-Delta 60 foot sloper antenna. He anticipates several QSLs and enjoys the QSL Column very much. Thank you for your comments...Sam.

ector. (Mann-NE). f/d form ltr. in 299 ds. for a PT rpt. and \$1.00. (D'Angelo-PA). f/d ltr. in 3 mo. w/ postcard. (Barto-CT).

BULGARIA: Radio Sofia 9700 2 cds. in 49 and 77 ds. (Mulrean).

CANADA: CFRX 6070 f/d cd. w/ personal note in 10 ds. for a FAXED rpt. v/s Stephen Canney (Ondrechen-MA). f/d cd. w/ schedule in 16 ds. for ms. (Berish). **Radio Canada International** 15305 f/d cd. in 17 ds.

RADIO INTERNACIONAL

for 1 IRC. (Dybka). **Radio Korea** 11715 via **Sackville** "Han River" cd. in 87 ds. (Humenyk). **CKZU** 6160 f/d "CBC Centre" cd. in 20 ds. for \$1.00. (returned) v/s Dave Newbury. (Trumm-CANARY ISLANDS: **RNE - Radio** el-MO).

* **Uno** 11430 f/d "Espana 82" cd. in 1 mo. w/ schedule. (Barto-CT).

CHINA, PEOPLES REP. OF: China Radio International 11000 and 15880 f/d cd. w/ stickers and paper cut in 5 wks. (Barto). 15110 f/d cd. w/ sticker and magazines in 81 ds. (Mulrean).

COSTA RICA: Adventist World Radio 5030 f/d cd. w/ personal ltr. and 2 different stickers, calendar and pennant in 7 wks. v/s Dave Gregory. (Barto-CT). same in 1½ mo. for a taped rpt. and ms. (Rausch-NJ). f/d cd. in 2 mo. for \$1.00. Stickers and pennant rcvd. (Kohlbrener-PA).

CUBA: Radio Rebelde 5025 p/d folder cd. in 1 mo. (Trummel). 4758 p/d cd. w/ decal and personal ltr. in 2 wks. for a SP rpt. v/s Iberlize Gonzalez Padua, Dpto. Relaciones Publicas. (Barto-CT) **Radio Habana Cuba** 6010 f/d cd. in 151 ds. for 1 IRC. (Mulrean)

CYPRUS: CBC 6180, 7125 and 9770 f/d "Station Photo" cd. in 7 wks. for \$1.00. (Ondrechen-MA)

CZECH REP: Radio Prague 7345 f/d cd. w/ schedule in 43 ds. Also rcvd. Monitor Klub membership info. (Warren-NJ).

DOMINICAN REP: Radio Amanecer 6025 f/d cd. of the "20th Anniversary of AWR" in 8 mo.



INTERNACIONAL

HRAQO/HONDURAS

Copie a cargo de esta OIG que EL SEÑOR

SAMUEL L. BARTO

de BRISTOL, CT. U. S. A.

efectivamente ha recibido nuestra señal en la frecuencia

4930 kHz en banda de 60 m.

Agradecemos su amable reporte, le felicitamos,

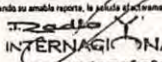

Sur Procter
Vice Presidente (Traf. Heraldo)
Director General

San Pedro Sula, 24 de ABRIL de 1994

BIENAS DE COPAN 20:50-21:03 HORA LOCAL

COPAN ALABE

FOTO: AJAN BENECK



SR. _____

SAM BARTO _____

U.S.A. _____

PRODUCCIONES RADIO INTERNACIONAL S. DE HONDURAS. El presente documento es propiedad de Radio Internacional.

© 1984 - ESCUELA DE DIB. S.A. Reproduction - Printed in Spain

for ms. Report was sent to the Indianapolis HQ. (Millard-TX). same cd. after 4 rpts. to the AWR Special Projects. (Trummel-MO).

ECUADOR: HCJB 9745 f/d cd. w/ pennant in 28 ds.

EGYPT: Radio Cairo 9900 f/d cd. (Yamada-NM).

w/ sticker and schedule in 60 ds. (Mulrean).

ENGLAND: Radio Korea 5965 via Skelton f/d cd.

in 87 ds. (Humenyk-ONT). VOA Wofferton f/d

cd. for 1710 in 2 mo. for \$1.00. (Dybka).

Radio Japan 5965 and 6155 via Skelton f/d cd.

in 5 wks. v/s H. Kawamoto. (Barto-CT).

EUROPEAN RUSSIA: Radio Moscow 12070 via Saint Petersburg

f/d "Moskva River" cd. in 7 wks. (Barto). 7280 f/d

"Kosmos Hotel" cd. in 1 mo. (Barto). 9530 via Armavir f/d

cd. in 1 mo. w/ personal ltr. (Barto-CT).

NOTES: Ross Omeau says that he was extremely pleased with the QSL from Radio Damascus. It only took 20 months with no f/up report. Not bad considering quite a few of us do not even get a response!...Sam Mike Hardester has sent out quite a few reports in the past few months. Now its just a question of waiting. Mike uses an ICOM R-70 and an untuned 200 foot random wire @ 10-12 feet above ground. Carl Mann sent in a news clipping regarding a possible name change for South Africa. Thank you...Sam.

9765 via Armavir f/d "Friendship House" cd. in 1 1/2 mo. (Barto). 15265 via Omsk f/d cd. in 1 1/2 mo. (Barto). 7380 via Ekaterinburg f/d cd. in 1 mo. w/ personal ltr. (Barto). 11675 via Kenja f/d "Moskva River" cd. in 7 wks. (Barto). 11980 via Serpukhov f/d cd. in 7 wks. (Barto). 15495 f/d cd. in 2 mo. (Barto). 17805 via Zhilyuyovsk f/d cd. in 2 mo. (Barto)

15485 via Mos-

cov f/d cd. w/

personal ltr.

in 71 ds. v/s

Mrs. Eugenia

Stepanova. (D'

Angelo-PA).

* Radio Baltica/

GPR2 12070 f/d

cd. w/ personal

ltr., schedule

and sticker for

2 IRCs. v/s

Oleg K. Rudnov.

(Rausch-NJ).

EUROPIRATE: Radio Delta 6275 f/d form ltr. in 6 wks. for 2 IRCs. This was * logged while in Denmark. 80 watts. (Ondrechen-MA). ka-TN).

FRANCE: Radio France International 9800 f/d cd. in 1 mo. for \$1.00. (Dyb-

FRENCH GUIANA: Swiss Radio International 13635 f/d "Appenzello - Shops

in the Main Street" cd. in 43 ds. (D'Angelo-PA).

GERMANY: Deutsche Welle 5960 n/d cd. in 2 wks. (Dybka). n/d "40th Anniver-

sary" cd. in 1 yr. (Trummel-MO). Radio Free Europe 7255 and 5970 via

Holzkirchen f/d cd. in 5 wks. (Ondrechen-MA).

GREECE: Voice of Greece 9380 f/d cd. w/ schedule in 101 ds. (Warren). 9420

f/d cd. w/

schedule in

109 ds. (Dacus)

HAWAII: KWHR 17555

and 17510 f/d

cd. in 5 wks.

(Barto). 17510

f/d cd. in 130

ds. v/s Loren

Holycross. (Mul-

rean). 17780

f/d cd. in 110

ds. (Mulrean).

HONDURAS: Radio

International

4930.6 p/d cd.



FREQUENCIES

B. MALAYSIA	6175 Khz	49 M
ENGLISH	15295 Khz	19 M
MANDARIN	11885 Khz	25 M
INDONESIA	6175 Khz	49 M
ARABIC	15295 Khz	19 M
THAI	6100 Khz	49 M
TAGALOG	1475 Khz	203.4 M
MYANMAR	6100 Khz	49 M

11-2-94 1248-1300 6175/9750.

Date UTC kHz

3ir.

Thank you for your reception report. We have with verify that on the above date + time you received a transmission of our Station (V.O.M.) directed to Indonesia.

The transmitter fed 100 kw into

a HR 2/2/0-38 12d B Antenna.

HAJAH WAN CHIK OTHMAN
 PUBLISHER SERVICE
 THE VOICE OF MALAYSIA



You'll be fascinated



Please address all correspondence to SUARA MALAYSIA (Voice of Malaysia) • P.O. Box 11212 • 50740 Kuala Lumpur • Malaysia. Fax: 800-250733 Tel: 603-275531 Telex: MA 30283 (RADIO)

w/ sticker and schedule in 37 ds. for a SP rpt. and ms. (Klinck NY). f/d "Copan Ruins" cd. w/ postcard, business cd., and different stickers in 5 wks. for a SP rpt. (Barto-CT).

Radio Copan International HRJA 15675 via **WRMI** f/d cd. in 97 ds. for ms. (Wilkins-MS). same in 218 ds. after a f/up rpt for ms. (Mann-NE).

* **La Voz de Centroamerica** 2120 n/d personal ltr. in 4 mo. for a SP rpt. v/s Jose Luis Maldonado, Director. (Field-MI).

HONG KONG: BBC 21715 n/d ltr. w/ schedule in 32 ds. for 1 IRC. (Yamada-NM).

HUNGARY: Radio Budapest 5970 f/d "Baranya National Costume" cd. w/ pennant and stickers in 2 mo. (Barto-CT).

INDIA: All India Radio 13750 via **Aligarh** f/d cd. w/ schedule in 117 ds. (Humenyk). 9950 and 7412 via **Khampur / New Delhi** f/d cd. in 2 mo. (Field-MI). 10330 via **Delhi** f/d "Temple" cd. in 2 mo. (Barto-CT). 13700 p/d "Kandariya

VERIFICATION SIGNERS: Radio Onda

Azul 4800 Mauricio Rodriguez R., Jefe de Programacion. **Radio Horizonte** 5019.9 Maria Dolores Gutierrez Atienza, Gerente or Angel Francisco Simon Pierno, Director Monsenor. **Radio Naylamp** 4300 J.J. Grandez Vargas, Gerente. **La Voz de la Selva** 4825 Julia Jauregui Rengifo, Directora. **Radio Tropical** 4935 Miss Mery A. Rengifo Tenaros, Secretary...via PLAY DX.



Mahadev Temple" cd. w/ postcard in 2½ mo. (Barto). 11715 via **Khampur** f/d cd. in 2 mo. (Barto-CT). 4940 via

Gwahati f/d "Temple" cd. in 6 wks. w/ schedule (Barto-CT). rechen-MA)

IRELAND: WGAS 6275 f/d sheet in 7 wks. for \$3.00. Hrd. in Denmark. (Ond-
ISRAEL: Kol Israel 15640 f/d cd. w/ schedule in 107 ds. (Humenyk). 11603 f/d cd. w/ booklet in 30 ds. (Berish). 7465 f/d cd. w/ pennant and schedule and requesting IRCs w/ rpts. in 28 ds. (Mulrean).

ITALY: Adventist World Radio 7230 f/d cd. in 3 mo. for \$1.00. (Ondrechen)

JAPAN: Radio Japan 5960 f/d cd. w/ schedule in 25 ds. (Lane)... Canada?

KARELO-FINNISH REP: Radio Moscow 5905 via **Kalinigrad** f/d cd. after a rpt. to the State Broadcast Radio Communications Company. (Field-MI).

KAZAKH REP: Radio Nederlands 7365 via **Alma Ata** f/d "CTS" cd. in 7 wks.

KIRIBATI: Radio Kiribati (Barto). 9825 f/d "Shark Fishing" cd. in 1 mo. for \$1.00. (Trummel-MO).

KOREA, PEOPLES DEMOCRATIC REP: Radio Pyongyang 13760 f/d cd. w/ schedule and propaganda in 61 ds. for \$1.00. (Lane). 13760, 15130 and 11335 cd. w/ pennant in 9 wks. (Barto). 6560, 7580 and 6540.2 f/d cd. in 9 wks. (Barto). 2 n/d ltrs. w/ pennant and book in 3 mo. (Trummel-MO).

KOREA, REPUBLIC OF: Radio Korea 11715 & 15575 p/d cd. w/ lapel pin and sked. in 34 ds. for 1 IRC. (Lane). 11715 cd. w/ schedule in 48 ds. for 1 IRC. (Mulrean). 13670 and 15575 "Han River" cd. w/ schedule in 87 ds. (Humenyk).

KUWAIT: Radio Kuwait 11990 f/d cd. w/ schedule in 111 ds. (Warren-NJ). large cd. w/ schedule and key chain in 119 ds. for 1 IRC. (Mulrean). f/d folder cd. w/ key chain and pen in 200 ds. for 1 IRC. (Lane).

AWR



**ADVENTIST
WORLD
RADIO
LATIN AMERICA**



NATIONAL BROADCASTING
AUTHORITY (Research Wing)
NSA HOUSE, SHAHABAG AVENUE
DHAKA, BANGLADESH.

Dear Mr. Adie N. Durden,

Thank you very much for your reception report
of 01/02/79. We are pleased to confirm that the
station you heard is Radio Bangladesh, operating on

15195 KHz. time 1230-1300 UTC.

Yours Sincerely

M. Khair
Senior Engineer
(Research Wing)



PLACE
STAMP
HERE

KYRGYZSTAN: Radio Moscow
17780 via Bishkek f/d
cd. in 2 mo. (Barto-CT).

LEBANON: Voice of Lebanon
6549.7 f/d ltr. in Ar.
for a taped rpt. and a
Hard Rock Cafe T-Shirt
which was hand delivered
by a Lebanese friend for
a visit. (Rausch-NJ).

Voice of Hope 11530 f/d

"Map" cd. in 6 wks. on my second try. v/s
Paul Johnson, Station Manager. (Field-MI).

LITHUANIA: Radio Vilnius 9530 f/d cd. in 30
ds. (D'Angelo-PA). f/d cd. in 32 ds. for 1
IRC. (Mulrean). 11770 f/d "Land of Amber"
cd. in 162 ds. (Mulrean).

NOTES: Father John Eckert says he finally got the new antenna up at the parish. He
prays that he will be able to hear those rare DX stations. Say one for all of us!
John Scruletta has moved his furniture out of the radio room to do some needed
panel work. Hopefully everything will be straightened out by next month. Another
new reporter is Don Dacus from Russellville, AR. He uses a Grundig YB500 and a
random wire antenna. Hope to see more reports from you in the future...Sam

LUXEMBOURG: Radio Luxembourg 15350 f/d cd. in 1 mo. for a taped rpt. &
\$2.00 (returned). (Rausch-NJ). rean).

MALAGASY: Radio Nederlands f/d cd. w/ schedule in 59 ds. for 1 IRC. (Mul-
MALAYSIA: Voice of Malaysia 6175 and 9750 f/d "Traditional Dance" cd. in
7 mo. w/ tourist brochure w/ schedule and sticker. (Barto-CT).

MALI: China Radio International 11717 f/d "Eastern Qing Tombs" cd. in 2
mo. For \$1.00. (Dybka-TN).

MEXICO: Radio Educacion XEPPM 6185 f/d cd. w/ sticker, schedule and in-
fo sheet in 3 wks. (Barto-CT).

MOLDOVA: Radio Moscow 11730 and 15290 via Kishinyov f/d cd. in 6 wks.

MOLDOVA (Pridnestrovia Rep.): Radio Dniester International (Barto-CT).

15290 f/d note w/ ltr. in 118 ds. for 2 IRCS. (Mann-NE). form ltr. in
110 ds. for \$1.00. v/s A. Komar, Chief Editor. (Comeau-MA). (Rausch).

NEWFOUNDLAND: CKZN 6160 f/d cd. in 3 mo. for ms. v/s Shawn Williams.

NEW ZEALAND (Pirate): Shortest Day Radio 7445 via Kiwi Radio smallest
f/d cd. (1 inch by 6/8 inch!) in 1½ mo. for \$1.00. Addr: P.O. Box
3174, Onekawa, Napier, NZ. (Trummel-MO). Kiwi Radio 7445 f/d "Rock of
the South Pacific" cd. w/ stickers and info. sheet in 1 mo. for \$1.00

NICARAGUA: YNPMK Radio Miskut 5770 f/d ltr. w/ prepared cd. (Trummel).
in 10 mo. for \$1.00. v/s Evaristo Mercado Perez, Director. (Trummel).

NORWAY: Radio Norway International 0655 f/d cd. w/ stickers in 72 ds.
(Warren-NJ).

PALAU: Voice of Hope 9965
f/d cd. w/ schedule in
25 ds. for 2 IRCS. (Yam-
ada-NM).

PARAGUAY: Radio Nacional
del Paraguay n/d ltr.
in EE w/ mint Paraguayan
stamps in 9½ mo. v/s Julio
Cesar Cardozo, Jefe de Per-
sonal. (Trummel-MO).

PERU: Radio Nueva Cajamarca
5800 4th f/up on a 1/93
reception. I got a ltr. back
from the PO stating that the
station no longer exists.
Guess I can forget
about this one! At least I got my
dollar back! (Durden-GA).

Adventist World



Latin America

Radio Lira International

Short Wave Band
19, 25, 31, 49 meters

Государственное Предприятие
Радиосвязи и Радиовещания № 2 (ГПР-2) No. 402
подтверждает сообщение о приеме, поступившее
от Mr. Ed Rausch
Дата 13th August 1994
Время 11.00 - 12.00 UTC
Частота 12070 kHz
Thank you very much
for your report!

Государственное
предприятие радиосвязи
и радиовещания № 2
(ГПР-2)
197376, Санкт-Петербург
Ул. Гва. Индиа Паркер, 13а

На данной частоте в указанное время
осуществлялась ретрансляция программы
SPECIAL JOINT TRANSMISSION GPR-2/R.BALTICA
через передатчик мощностью 2 x 200 kW
расположенный в St. Petersburg (Popovka)
антенна curtain/2B3

Служба подтверждений ГПР-2

PERU: Radio San Martin

4810 small p/d cd.
w/ ltr., sticker &
slick magazine in
825 ds. for a SP
rpt. on my 7th f/up
rpt. v/s Fernando
Tafur Arevelo, Ger-
ente General. (Dur-
den-GA).

* **Radio Villa Rica** 4805 p/d "Cer-
tificado de Sinton-
ia" in 576 ds. for
a SP rpt. and 4 f/up
rpts. v/s Fidel Hil-
ario Huamani, Direc-
tor de Programas &
Maritza Pozo Manri-
que, Asoc. de Locu-
tores-Hvca. Also rcvd. photographs of Cerro Potoqchi. (Durden-GA).
PHILIPPINES: FEBC 11995 f/d "Hibiscus Flower" cd. in 3 mo. for 3 IRCs.
PORTUGAL: Radio Portugal Internacional 17745 f/d "Old (Ondrechen-MA).
World" cd. w/ sticker and schedule in 166 ds. (Humenyk-ONT).
RUSSIA: Radio Moscow 9750 f/d cd. in 58 ds. (Mulrean). 11750 f/d cd. in
62 ds. (Lane). **RWM Time Signal Station** 9996 and 14996 2 f/d cds. in 1

NOTES: Jerry Klinck says he is out of control! He has sent out as many reports this
season as he did for the entire last year. Guess he just got the urge. Jerry wishes
everyone a very happy thanksgiving. **Jill Dybka** is a new NASWA member and has sent
in her first report. She is a student and says that writing reception reports lets
her practice her Spanish and Russian.

mo. for \$1.00. (Trummel-MO).

SAUDI ARABIA: BSKSA 5870 and 5875
n/d form ltr. in 3 mo. w/ sked.
(Barto-CT).

**SINGAPORE: Radio Singapore Inter-
national** 9530 f/d "Skyline" cd.
in 4 mo. for 1 IRC. Also rcvd.
sticker, schedule and key chain.
(Millard-TX).

SLOVAKIA: Slovak Radio 5930 f/d cd
in 43 ds. (Mulrean). **Adventist
World Radio** 9465 via **Rimavska
Sobota** f/d "Morse" cd. w/ sked.
in 12 ds. via the Ohio addr.
(Dybka).

SOUTH AFRICA: Channel Africa 5955
f/d cd. w/ schedule in 43 ds.
for 1 IRC (returned). (Warren-NJ).
9730 f/d "Durban Seaport" cd. in
4 mo. (Ondrechen). 9695 f/d cd.
in 39 ds. for 2 IRCs (returned).
(Mann-NE). 9585 f/d cd. in 29 ds
for \$1.00. Sticker and schedule
* rcvd. (Dacus-AR). **Deutsche Welle**
6015 via **Meyerton** f/d cd. w/
site in 29 ds. (Buer-FL).

SPAIN: Radio Exterior de Espana
9620, 6125 and 11945 f/d "Espana
82" cd. in 1 1/2 mo. (Barto). 9540
f/d "Sevilla Exposition" cd. w/
schedule in 2 mo. for \$1.00. on
3rd try! (Dybka-TN). f/d cd. w/
schedule in 83 ds. (Berish).

SPANISH MOROCCO: Radio Medi Un 9575
via **Nador** f/d cd. in 4 mo. for a FR
rpt. and 2 IRCs. (Ondrechen-MA).

PERU
NAYLAMP
REGION ORIENTAL DEL MARAYKA
CIUDAD EVOCADORA
DIOS NAYLAMP
OREJERA SENOR DE SIPAN
CUNA DEL SENOR DE SIPAN
AV. HUAMACHUCO 1080
TELF. 28 33 53



SOCIALIST REPUBLIC OF VIETNAM
RADIO THE VOICE OF VIETNAM

Verification

To.....John Mac Donald, P.H.D......
Thank you for your Reception at 19:00 UTC... on 15.2.80. My...
on.....Daily S.H. 1.994..... All details of
your Report of Reception correspond well with our station log. With the
compliments of the Director of the Overseas Service of the Voice of Vietnam.

Hani August 8/2 1994
OVERSEAS SERVICE, VOICE OF VIETNAM

58 Quan Su Street, Hanoi

NOTES: Jerry Klinck has added a second R-8 to replace the backup R-5000 receiver for the new DX season. He has also constructed a new 25 meter dipole and a second 60 meter dipole. Also placed a balun from Universal at the feed point of the 80 foot longwire fed with co-ax. Great difference in noise control! I expect a verie good DX season....So do I! Thomas Millard is back stateside after a 4 month photo assignment in Australia. I shot in and around Darwin and visited Katherine, Tennant Creek, and Wanneroo. Sounds like you had a great job assignment...Sam.

for \$1.00. (Trummel). f/d cd. w/ schedule, sticker and newspaper in 86 ds. via registered mail. (Warren-NJ). 12085 f/d cd. w/ schedule in 118 ds. (Mulrean).

**RADIO MAGIC IS FREE BROADCASTER
AND FREE RADIO LISTENER**

QSL #13

TO: Chris Ledell USA
FQ: 7385 USB to WAPA?
DATE: 17-4-84
TIME: 00:30:00 CEST
SINRO: 455



RM

RM, BOX 1461
PERM 614036
RUSSIA
"Star"

w/ ltr. and schedule in 39 ds. for \$1.00. (Klinck-NY). same in 5 wks. v/s Mrs. Amporn Samosorn, Chief of the External Service. (Kohlrenner).

TURKEY: Voice of Turkey 9445 f/d cd. w/ sticker and schedule in 45 ds.

UKRAINE: Radio Moscow 15380 via Simferopol f/d "Moskva River" (Lane). cd. in 7 wks. (Barto-CT). 15290 f/d cd. in 71 ds. (D'Angelo-PA).

USA: WRMI Radio Miami International 9955 f/d cd. in 22 ds. for ms. v/s Jeff White. (Buer-FL). f/d cd. in 3 mo. for SASE. (Trummel). f/d "Palms and Ocean" cd. in 17 ds. (Mann-NE). La Voz de la Fundacion 9955 via WRMI f/d cd. w/ sticker and info sheet in 1 mo. v/s Jeff White. (Barto-CT). WNZE748 Roosevelt Island Operating Corp. 1619.9 p/d ltr. in 3 wks. v/s Barry Chafetz. Addr: 591 Main St., Roosevelt Island, NY, NY 6 watts! (Barto-CT). KTBN 15590 f/d cd. in 120 ds. (Mulrean).

SWAZILAND: Trans World Radio 7125 f/d "Transmitter Site" cd. w/ schedule in 1 mo. for \$1.00. (Trummel). 5055 same cd. in 26 ds. for \$1.00. (D'Angelo-PA).

SWEDEN: Radio Sweden 15240 f/d cd. w/ schedule and sticker in 13 ds. (Berish). 6195 f/d cd. in 17 ds. (Klinck-NY).

SUDAN: Radio Omdurman 9550 f/d form ltr. in 1802 ds. for 2 IRCs. after 2 f/up rpts. v/s Mohd. El-mahdi Khalil. (Mann-NE).

SYRIA: Radio Damascus 15095 f/d cd. w/ sticker, flag and schedule in 1 yr.

TAIWAN: Voice of Free China 17750 f/d cd. w/ sticker and schedule in 31 ds. for 1 IRC. (Lane).

TAJIKISTAN: Radio Nederlands 9860 f/d "Staff" cd. in 4 mo. for 2 IRCs. (Rausch-NJ).

TANGIER: RTVM 17595 f/d "Map/Logo" cd. in 1 yr. for \$1.00. (name?) 9530 f/d cd. w/ sticker in 10 ds. (Berish).

THAILAND: Radio Thailand 11845 f/d cd. w/ schedule in 34 ds. for 1 IRC. (Yamada-NM). same w/ ltr. in 6 wks. (Field-MI). 15370 p/d cd.



RADIO REBELDE

La Habana,
Cuba

¡Al Ritmo de la Vida!





American Dissident Voices 7395 f/d cd. in 100 ds. (Pasz-kiewicz). 7355 via **WRNO** f/d cd. in 1 mo. w/ catalog. (Trummel). **Voice of the OAS** 15160 p/d cd. in 214 ds. for \$1.00. Also rcvd. magazine and pennant. (Comeau-MA). very informative and colorful magazine w/ white pennant in 5 wks. but no QSL. (Barto). 15160 same w/ f/d cd. in 7 mo. for \$1.00. (Kohlbrenner). **WEWN** 13615 f/d cd. in 18 ds. w/ schedule, 1 tr., and sticker. (Dybka-TN) 7425 f/d cd. w/ personal ltr. in 23 ds. for SASE. v/s Gary Gagnon (KE4XLI). (Klinck-NY). **KJES** 11715 cd. in 3 wks. (Field-MI). **WJCR** 7490 f/d cd. w/ schedule in 64 ds. for ms. (Berish). **WCSN** 7465 f/d prepared cd. in 9 mo. for SASE. (Trummel-MO). 9455 f/d cd. in 1 yr. for a rpt. to the Costigan, ME addr. v/s Frank L. Hoskins Jr. (Trummel). **WWV** 15000 f/d cd. in 12 ds. for ms. (Berish). f/d cd. in 16 ds. (Weissborn-TX). **WRNO** 15420 p/d cd. in 38 ds. for SASE. v/s Gerri Powell. (Berish) 7355 n/d "Willie Nelson" cd. in 3 wks. (autographed) for a rpt. on the Outlaw for Peace program. (Dybka-TN). **VOA Bethany** 9575 f/d cd. in 28 ds. (Berish). **VOA Greenville** 7405 f/d "Sunrise" cd. in 54 ds. (Comeau-MA). **WYFR** 11830 f/d cd. in 12 ds. for ms. (Weissborn).

USA (Pirates): Caribbean Sound System 7385 f/d cd. in 2 wks. via Stoneham addr. (Trummel). f/d cd. in 25 ds. for 3 ms. (Comeau-MA). **K2000** 7385 f/d sheet in 1 mo. (Trummel). 7470 f/d cd. in 22 ds. for 3 ms. (Comeau). **RKNA** 7375 f/d "Bill Clinton" sheet in 32 ds. for 3 ms. (Comeau). **WEED** 7465 n/d sheet in 8 mo. via Huntsville addr. (Trummel). 7385 same in 100 ds. (Pasz-kiewicz). **KNOM** 7385 f/d QSL #3 in 59 ds. for ms. (Pasz-kiewicz). **Altered States Radio** 7470 f/d sheet in 1 mo. via Merlin addr. (Trummel). **6YVOS The Voice of Smoke** 7386 f/d color cd. w/ large and small pennant in 1 mo. via Wellsville. (Trummel). f/d sheet in 44 ds. for 3 ms. (Comeau) **KDED** 13900 f/d large cd. in 25 ds. for 3 ms. Also rcvd. personal ltr. (Comeau). **Up Against the Wall Radio** 7385 f/d cd. w/ personal ltr. in 39 ds. for 3 ms. via Wellsville addr. (Comeau). **Heavy Dude Radio** 7415 via **NAPRS** f/d card w/ stickers in 6 mo. (Trummel). **The Joint** 7384 f/d sheet in 1 mo. for a log in ACE. (Trummel). **Radio 13 International** 7385 f/d cd. in 1 mo. for a log in ACE. (Trummel). **WRFW Radio Free Wisconsin** 7378 2 f/d sheets in 2 mo. (Lobdell). **The Voice of Broadcast Freedom** 7412 f/d sheet w/ ltr. in 1 mo. via BRS addr. (Lobdell-MA).

UZBEKISTAN: Radio Tashkent 17745 and 15420 f/d "Map" cd. w/ personal note in 4 mo. v/s Mrs. Nadira Babajanova. (Ondrechen). **Radio Nederland** 17655 via **Tashkent** f/d cd. in 39 ds. after a f/up rpt. (Buer-FL).

VENEZUELA: Radio Rumbos 9660 f/d "Caracus" cd. in 37 ds. for a SP rpt & \$1.00. Also rcvd. postcard. (Dybka-TN).

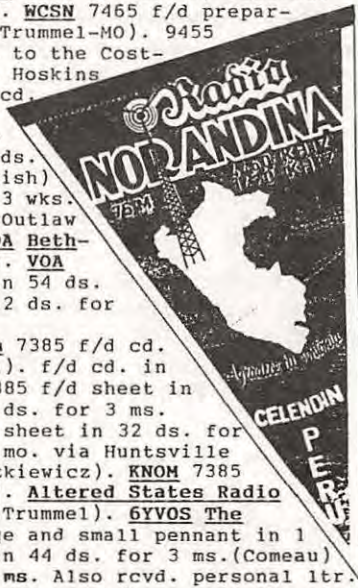

MITTERNACHTSRUF

Empfangsbestätigung von Radio MITTERNACHTSRUF
 CS1 8130 Pöhlhorn 21
 Schulstrasse 28
 Postfach 210
 Telefon (0)1 950 10 42
 Telefax (0)1 950 11 00

WEST IRIAN:
RRI Serui
 7173.2 f/d
 1 tr. in 2
 mo. for an
 IN rpt.
 (Barto-CT).
YUGOSLAVIA:
Radio Yugo-
slavia
 9620 f/d
 cd. in 1
 mo. (Barto)



"Er sendet Seine Rede auf Erden, Sein Wort kühlt schneet." Ps. 147,15

Hiermit bestätigen wir Ihnen Ihren Empfangsbericht: Sie hörten Radio MITTERNACHTSRUF über AR-Intercontinental 11790 kHz / UTC 21.00' - 21.30 Uhr

Plättikon, 6. Oktober 1994

Wir danken Ihnen für Ihr Schreiben. Mit separater Post erhalten Sie noch mehr Info-Material über den Verlag und Radio Mitternachtsruf. Mit freundlichen Grüßen

Jonathan Malgo
 Jonathan Malgo

Herrn
 Richard A. D'Angelo
 2216 Burkey Drive
 19610 Wyomissing PA
 U.S.A.

Till next month....73s

Contributors' Page

John Schmid
P.O. Box 86
Line Lexington, PA 18932

LOGGINGS CONTRIBUTORS - December 1994 - DEADLINE 10th of MONTH

The following members contributed loggings:

- Brian ALEXANDER , Mechanicsburg , PA
Jerry BERG , Lexington , MA
Julianna L. BICKUS , Herndon, VA
William BROWN, Independence, MO
Joe BUCH, Cape Hatteras, NC
David M. CLARK, Newmarket, ON
Richard D'ANGELO , Wyomissing , PA
William DAVENPORT , Nashville , TN
Walter FAIR, Houston, TX
Marlin FIELD, Hillsdale, MI
Bill FLYNN , Cave Junction , OR
Harold FRODGE, Midland, MI
Harold FRODGE, Anyar, West Java, INDONESIA
Harold FRODGE, Brighton, MI
Tony GERMANOTTA, Cape Hatteras, NC
Pete GRENIER, Sparks, NV
Mike HARDESTER, Jacksonville, NC
Scott JERRIS, Morgantown, WV
Rufus JORDAN, Pittsburgh, PA
Marv KAMINSKY , Flanders , NJ
Jerry KLINCK, West Seneca, NY
Fred KOHLBRENNER, Philadelphia, PA
Fred KOHLBRENNER, DXpedition, PA
Marie LAMB , Brewerton , NY
- Ernest LAWRENCE , Perry, NY
Harold LEVISON , Philadelphia , PA
John LYON , White Bear Lakes , MN
William McGUIRE , Cheverly , MD
Bob MONTGOMERY, Levittown, PA
Don MOORE , Davenport, IA
Ed NEWBURY, Bridgeport, NE
Tony ORR, Reston, VA
Marina PAPPAS, Huron, SD
Sheryl PASZKIEWICZ, Manitowoc, WI
Ed RAUSCH, Cedar Grove, NJ
Chuck RIPPEL , Cornland, VA
Chuck RIPPEL , Cape Hatteras, NC
Doug ROBERTSON, Oxnard, CA
Betsy K. ROBINSON, Clinton, TN
Mike RYAN , Bangkok , THAILAND
Giovanna SERRA, Rome, ITALY
Todd SMITH, Norwalk, CT
James STREITMATTER, Elkhart, IN
Nick TERRENCE, Huntington, NY
Jack THOMPSON , New York , NY
Robert TUCKER, Savannah, GA
Errol URBELIS, Kings Park, NY
- NRD 535D Vs Longwires
R8 R390A HQ180A 150' LW
R8 Eavesdropper Indoor Vertical
R8
Lowe Europa 2010 FT890AT 400' & 500' wires
2-R8s 2-R7s HQ180C Beverages
R8 FL3 AD Sloper Farley Loop
DX380 ICF7601 AN1
R71A 65' wire
NRD535D Eavesdropper
R8 R7A 500' loop 83' Dipole
R71A MFJ956 80' & 185' RW's
INDONESIA ICF2002 30' RW
R71A MFJ956 500' RW
Lowe Europa 2010 FT890AT 400' & 500' wires
FRG7 ATS803A MFJ1020A 120' loop
R70 200' LW
SW77 random wire
DX302 Transoceanic indoor wire
NRD535D Random Wire
2 R8's HQ180 80' LW Dipoles
R8 NRD525 AD Sloper Datong FL3
R8 NRD525 FL3 mini beverages
HF150 ATS803A DX375 MFJ10610 60M LW Indoor
Dipole
NRD525 DX440 Dipole LW
R8 R70 D2999 Indoor LW
TS940S HF225 MFJ949D 40-10 M Dipoles 8JK
DX380
NRD525 FL3 ARA60 Active Antenna
R8 2 400' mini-beverages
R8 R5000 70' Windom
R70 HF150 R1000 MFJ16010 70' 100' randoms
R8 DX400 indoor random
NRD515 NRD525 60' LW Eavesdropper
R5000 2010 MFJ959 Eavesdropper 300' Dipole
Yaesu FT1000 Lowe Europa R390A SP600JX1 51S1
Lowe Europa 2010 Yaesu FT890AT 400' & 500' wires
DX302 FRG8800 FRA7700
Sony 2010 Indoor Telescopic Antenna
2 Sony 2001DS's
NRD525 AD Sloper
SW60
R8 LW's
Grundig YB400 ICF SW33
ATS803A
TS940SAT FT980 100' end fed LW Antron 99 vertical

Hello again and greetings to all. I had the pleasure of talking with Andy Sennitt and Bart Kuperus, the editors of the WRTH, at the Nov. NASWA meeting in Kulpsville. I got the real inside story on how the book is put together and an appreciation of their efforts to keep it as up to date and accurate as possible. These guys do a great job! Happy Holidays! See you next year..

Tropical Band Loggings

Sheryl Paszkiewicz
1015 Green Street
Manitowoc, WI 54220



- 2310 AUSTRALIA VL8A 10/15 1207 30s mx //others (Frodge-MI2)
 2325 AUSTRALIA VL8T 10/15 1207 30s mx (Frodge-MI2)
 2390t GUATEMALA LV de Atitlán 9/22 0250 tlk, mx, noisy! (Flynn-OR)
 2485 AUSTRALIA VL8K 10/15 1207 30s mx (Frodge-MI2)
 3200 SWAZILAND TWR 10/27 0300 rel not //3240 (Field-MI)
 3200h USA 10/16 1131 Q94.9 promo, pops, poor (Frodge-MI2)
 3230 SOUTH AFRICA Orion 10/22 2215 pops, RTTY QRM (Brown-MO)
 3249.9 KALIMANTAN Banjarmasin 10/29 2204 nx, ID, tnx Valko (D'Ang)
 3260 NEW GUINEA Madang 10/23 1130 PNG chorus, fair (Brown-MO)
 3266 SUMATRA RRI Bengkulu 10/16 1140 pop, nx, speech (Frodge-MI2)
 3283.8p ECUADOR Rio Tarqui 10/6 1031 non-stop tlks (D'Angelo-PA)
 3289.9 ECUADOR R Centro 10/10 1016 rapid nx, TCs, ads (D'Angelo-PA)
 3304.8 TIMOR RRI Dili 10/16 1135 EZL, SCI, weak (Clark-ON)
 3305 NEW GUINEA R Western 10/9 1047 lcl mx, PD tlk (Klinck-NY)
 3315 INDIA Bhopal 10/29 0114 Hindi vlcs, TP 0130 nx (D'Angelo-GP)
 11/9 1145 Hindi tlks, //4920 (Rippel-VA)
 3322.2 TOGO R Kara 10/22 2251 chorus, NA to 2301* (Brown-MO)
 3323 INDIA Simla 11/5 0110 SC mx poss //3365 (Rippel-VA)
 3324.8 GUATEMALA R Maya 10/28 1054 rel, ID, calls (Kohlbrenner-PA)
 3325p SUMATRA Palangkaraya 9/29 1420 slow tlk, ment Palang. (Flynn)
 3340 PERU R Altura 10/4 *0930 NA, ID, flute, rooster (Rausch-NJ)
 10/22 0956 OA mx, tlk, IDs (Klinck-NY)
 3345 INDIA Jaipur 10/29 0120 Hindi IDs, sitar, poor (D'Angelo-GP)
 3345p NEW GUINEA R Northern 10/15 1142 chor, pops, OM (Frodge-MI2)
 3355 NEW GUINEA Simbu 10/23 1153 C&W, OM DJ (Brown-MO)
 3356 BOTSWANA RB 10/19 0326 EG tlk, pop, nx, low mod (Serra-ITALY)
 3360 GUATEMALA LV Nahualá 10/28 1119 tlk, brief mx, ID (Klinck-NY)
 3365p BRAZIL RC Araraquara 10/15 1132 PT OM w/EG oldies (Frodge-MI2)
 3365 INDIA Delhi 11/5 0140 Hindi tlks, SC mx (Rippel-VA) 10/30
 0057 Hindi, ID, TP nx, fair (D'Angelo-GP)
 3365 NEW GUINEA Milne Bay 10/9 1126 EG mx, ID (Klinck-NY)
 3366 GHANA GBC 10/22 2130 Big Band mx, hets (Brown-MO) 10/26 0451
 EG instl, Rod Stewart, ID, chor, tlkg drums, nx (Lamb-FL)
 tent 10/22 0522 tlk, pops, poss EG (Serra-ITALY)
 3375 ANGOLA RN 10/27 *0358 drums, ID not //4950 (Field-MI) 10/15
 0438 in lang w/Afropops, ID, fair (Frodge-MI2)
 3375 BRAZIL unid 10/27 0330 PT mx, off abruptly 0355 (Field-MI)
 3380 GUATEMALA R Chortis 10/9 0150 SP concert, good (Newbury-NE)
 3380.6 MALAWI MBC 11/13 0305 EG vlcs/percuss, ID (Streitmatter-IN)
 *3450U PIRATE R Bob's Commnet 10/23 0300 ID, Pgm 4, Atl addr (Frodge)
 3810 ECUADOR HD2IOA 10/4 0740 SP ID, hrd till past 1200 (Montgomery)
 3905 IRIAN JAYA Merauke 10/30 1148 EZL, SCI (D'Angelo-GP) Nice
 3912 CLAND Vo People (S KOR) 10/3 1434 KR pgm, jammed (Flynn-OR)
 3915 SINGAPORE BBC 10/22 2230 Big Ben, IN nx, (Clark-ON)
 3925 JAPAN R Tanpa 10/27 1232 JP tlks, ARO QRM (Grenier-NV)
 3945 INDIA Delhi *1330-*1545 Delhi relays, no site ID (Ryan-THAI)
 3955 SOUTH AFRICA Channel Afr 11/9 0339 Chichewa mx, ID, cochannel
 BBC Skelton, tnx Sheryl (Lamb-BY)
 3985 CLAND S KOR 10/31 1418 KR mx bridges, ID, tlk (Robertson-CA)
 4010 KYRGYZSTAN Kyrgyz R 9/29 1740 vlcs, ballads, ID Biskekden
 Soylobuz (Ryan-THAILAND)
 4409.3 BOLIVIA Eco 10/26 2318 ballads, IDs, ad string (Kohlbrenner)
 4460 CHINA CPBS Beijing 10/31 1435 CH mx pgm, pres ID (Robertson-CA)
 4505 PERU R Horizonte 10/12 1016 OA mx, IDs (Klinck-NY)
 4600 BOLIVIA Perla del Acre 10/11 0957 long tlk, rustic vcl (D'Ang.)
 10/12 1027 lcl mx, IDs, TCs (Klinck-NY)
 4635 TAJIKISTAN Tajik R 10/11 1600 IS ID, tlks to 1900* (Ryan-THAI)
 4712.6 BOLIVIA R Abaroa 10/9 1005 mx, IDs, amnts (Klinck-NY)
 4747.5 PERU Huanta 2000 10/26 2344 IDs, atenciones, QTH (Kohlbrenner)

10/12 1030 OA mx, clear IDs, anmts, gone 1047 (Klinck-NY)
 4753 SULAWESI Ujung Pandang 10/16 tlk, EZL //others (Frodge-MI2)
 4755 BRAZIL R Ecuc Rural 10/9 0155 contemp mx, poor (Newbury-NE)
 10/30 1441 PT tlk/mx, 1451 ID (Robertson-CA)
 4755.2 BRAZIL Rdf Maranhao 11/2 0601 PT anmts, IDs (Klinck-NY)
 4760 ANDAMAN AIR Pt Blair 10/29 1138 SC, tlks (Clark-ON) 10/9
 1230 Delhi EG nx //4800 (Ryan-THAILAND)
 4760 LIBERIA ELWA 10/26 2207* Quiet Time, ID, NA (Kohlbrenner-PA)
 10/9 2203* EG ltrbox, messages, addr, rel ID (D'Angelo-PA)
 10/27 1753 EG pops, TC, ID, poss nx, rel song (Serra-ITALY)
 4765 BRAZIL R Rural 10/23 0251 vcls, ID, TCS, Brasil (Paszkiwicz)
 10/27 0837 Braz pops, promo, ID, addr (Lamb-FL)
 4765 CONGO R Congo 11/7 0402 FR IS, ID, mx (Fair-TX)
 4775 INDIA Imphal tests often *1130-1700* ID, Delhi relays (Ryan)
 4779.8 GUATEMALA Cult Coatan 11/9 0043 IDs, vcls, rel (Paszkiwicz-WI)
 10/23 0147* tlks, ID, rel mx, weak (Alexander-PA) 10/27 *1101
 IDs, mx (Kohlbrenner-PA) 10/26 0030 tlk, IDs, mx, FC (Field-MI)
 11/2 1126 mx, anmts, ID, addr (Klinck-NY)
 4780 N KOREA Pyongyang 10/27 1238 KR pop mx (Grenier-NV)
 4780 UKRAINE RU 11/13 0545 tlk lang, EZL, IS (Paszkiwicz-WI) 11/15
 0104 EG nx, Ukraine Today, Close UP, //others (Lamb-NY)
 4782.9 MALI Rdf Malienne 10/22 2235 FR hilife, nx (Montgomery-PA)
 4785 PERU R Cooperativa 11/3 0029 ID, OA mx, anmts (Klinck-NY)
 4785.7 COLOMBIA Ecos del Combeima 10/28 0958 ballads Super IDs (Kohl.)
 4790 PERU R Atlántida 10/11 1005 rooster, ID, vcls (Davenport-TN)
 10/12 1035 tlk, IDs, armchair copy (Klinck-NY) 10/16 1028
 Andean mx, TCS, anmts (Frodge-MI2)
 4797.7 GUATEMALA Buenas Nuevas 11/2 1134 rel, ID, TCS (Klinck-NY)
 4800.1t LESOTHO RL 11/7 0345 mx, chants, weak (Fair-TX)
 4805 BRAZIL Rdf Amazonas 11/6 0004 ballads, pops, ID (Streitmatter)
 4810 SOUTH AFRICA R 2000 10/28 0335 sports tlk EG/AK (Grenier-NV)
 10/3 2335 EG elevator mx, best copy ever (Montgomery-PA) 10/4
 0220 EZL, folk mx in AK, good (Newbury-NE) 11/7 0305 AK tlk
 EZL, AK nx (Fair-TX) Afrikaans Stereo after 0300
 4810.2 PERU San Martin 10/11 1016 tlk, TC, ID, promos (Davenport-TN)
 4815 BRAZIL Rdf Londrina 10/30 1453 PT mx, tlk, pres ID (Robertson)
 4820v HONDURAS HRVC 11/2 1104 rel pgm, mx, fair (Pappas-SD)
 4823.7 PERU LV de la Selva 11/6 0152 IDs, Happy B'day (Streitmatter)
 10/14 1015 LA mx, promos, ID, good (Newbury-NE)
 4830 BOTSWANA RB 10/22 0430 UN nx, ID, good (Davenport-TN) 10/27
 0353 EG/Setswana Beatles mx, soul, ID, nx, Bad Company (Lamb-FL)
 4830 VENEZUELA Táchira 10/24 0109 nx, jingles, ads (Montgomery-PA)
 10/14 1040 salsa mx, ID, promos, good (Newbury-NE) 10/16 1044
 campesino mx, YV calendar, lite instls (Frodge-MI2) 11/7 0245
 anmts, ads, TC, ID (Fair-TX) Tnx for yr input!
 4831.8 COSTA RICA Reloj 11/7 0435 LA mx, ID (Fair-TX)
 4835v GUATEMALA Tezulutlán 11/2 1134 lang names, mx (Pappas-SD)
 10/30 0200 tlk, ID (Kaminsky-NJ)
 4840 VENEZUELA R Valera 10/27 0352* LA mx, IDs, state & NA (Lamb-FL)
 4845 GUATEMALA Kekchi 11/6 0214 IDs, slow vcls, fair (Streitmatter)
 tent 11/7 0035 rel, maybe not SP, Mauritania QRM (Fair-TX)
 10/30 1458 tlk, ID to 1500* (Robertson-CA)
 4845 MAURITANIA ORTM 10/22 0059 Koran mixing w/Fides (Brown-MO)
 11/7 0045 AR Koran, under unknown SP (Fair-TX)
 4855.4p PERU R La Hora 10/27 1018 mx pgm (Field-MI)
 4870 BENIN ORTB 10/24 2217 FR tlk/mx, 2300* mx, NA (Montgomery-PA)
 11/2 0553 FR tlk, mx bridges, ID (Klinck-NY) 10/26 0518 FR ID
 nx, kids singing, drums (Lamb-FL)
 4870t ECUADOR Centinela del Sur 10/29 0200* mx, NA (Alexander-PA)
 4875 BRAZIL Rdf Roraima 10/16 0350 chor, ment Conga, ID (Flynn-OR)

4875t GEORGIA Tbilisi Georgian? 10/19 0404 nx, pops (Serra-ITALY)
 4880 BRAZIL Rdf Acreana 10/20 0954 PT mx bridges, ID (Klinck-NY)
 4883.2 BANGLADESH RB 10/23 1250 SC vcls, ute QRM (Brown-MO)
 4884.3 COLOMBIA Ondas del Meta 10/28 2300 mx, ads, fone #, ID (Terr.)
 10/16 1100 ID promo, ballads, instl (Frodge-MI2) pres 10/26
 0527 pops, tlk, pres ID, ment Villavicencio (Lamb-FL) 10/16
 0320 SP tlk, LA mx, ID (Kaminsky-NJ)
 4885t KENYA KBC 9/30 2039 Phil Collins, lang tlk (Serra-ITALY)
 4890 GABON RFI 10/22 0415 Afr mx, FR tlks, nx (Davenport-TN)
 4895 SARAWAK Kuching 10/23 1256 long tlk, ute QRM (Brown-MO)
 4904.5 CHAD RNT 10/11 2111 FR discuss by 2M (Klinck-NY) 10/7 0501
 FR tlk, Afropops, static (Serra-ITALY)
 4904.8 PERU La Oroya 10/28 1034 huayños, TCs, IDs (Kohlbrener-PA)
 10/11 1012 OA mx, anmts, IDs, TCs (Klinck-NY)
 4909.7 ZAMBIA ZNBC 10/9 0355 Afr hilife, ID, nx (Klinck-NY) 10/27
 0328 EG/lang mx, reggae, ID (Lamb-FL)
 4910p CAMBODIA Natl Vo Camb. 11/9 1155 SEAs mx, tlks (Rippel-VA)
 4914.5 PERU R Cora 10/11 1031 tlks, TC, ID (Davenport-TN) 10/15 1040
 anthem, shouted Peru, tlk, fair (Newbury-NE)
 4915 CHINA Guangxi PBS 11/5 1500 CH tlks, TP (Grenier-NV)
 4915 GHANA GBC-1 10/21 0045 EG nx, ID, NA (Davenport-TN) 09/29 2225
 choral rel mx, TC, ID, heavy static (Newbury-NE) 10/2 0550
 native vcls, ID, EG nx (Frodge-Mil) 10/3 1948 tlk, tribal mx,
 tam-tam IS, TP, ID, EG nx (Serra-ITALY)
 4920p INDIA Madras 11/5 0130 SC mx, tough copy (Rippel-VA)
 4925t SUMATRA RRI Jambi 10/30 1132 IN nx?, lcl mx (Klinck-NY)
 4930.6 HONDURAS R Internacional 10/29 2329 ads, ID, good (Terrence-NY)
 10/15 0445* IDs, pops, ballads, 4-note melody (Alexander-PA)
 10/20 0130 IDs, TC, ballads (Davenport-TN) tent 9/27 0226
 hymns, tlk, poor (Flynn-OR) 11/7 0225 pop & marimba mx, anmts
 ID (Fair-TX) Sorry, I'm not online, Walt.--sp 10/19 0414 ads
 slogans, romantic mx (Serra-ITALY)
 4931.5t CHINA Honghe PBS 9/27 1402 CH trad mx, poor (Flynn-OR)
 4940 INDIA Guwahati 10/4 1530 Delhi EG nx //others (Ryan-THAILAND)
 4955 PERU Cultural Amauta 10/29 *1006 NA ID, OA vcls (D'Angelo-GP)
 10/12 1045 Quechua? tlk ID, gone by 1100 (Klinck-NY)
 4957.5 AZERBAIJAN R Baku 10/25 1737 FR tlk, mx, tent ID (Serra-ITALY)
 4959.9 DOM REP R Cima 10/15 1110 tlk, folk mx (Newbury-NE)
 4960.3 HONDURAS HRET 10/15 0313* tlk, rel, IDs, addr, tune (Alexander)
 10/27 0313* SP/lang Christian concert, ID, rel (Lamb-FL)
 4965.9 PERU San Miguel 10/11 1016 OA vcls, IDs, TCs (D'Angelo-PA)
 4970 SABAH RTM Kota Kinabalu 10/30 1135 Malay tlk/mx (Klinck-NY) ID?
 4976 UGANDA RU 11/6 0400 EG ID, nx, static (Streitmatter-IN) 10/28
 0411 EG nx, cmtry w/baby sfx (Kohlbrener-PA) 10/28 2059* Bye
 Bye Love, Lonesome Me, ID (D'Angelo-PA) 10/28 0347 EG nx, cmtry
 on Rwanda (Klinck-NY)
 4980 VENEZUELA Ecos del Torbes 10/11 1100 Sat pgm, bank ads (Daven.)
 11/5 0045 kids greetings, comment stn for helping kids (Bickus)
 4985 BRAZIL Brasil Central 10/12 0120 echo anmts, ID, TC (Davenport)
 4990 ARMENIA Yerevan 10/26 1747 AR nx //4810, fair (Serra-ITALY)
 4990v NIGERIA R Nigeria 1 10/7 0445 tlk, rel? ID, chant (Serra-ITALY)
 4991 PERU R Ancash 10/27 0856 folk, ID, addr, jingle, ads(Lamb-FL)
 4991.1 BOLIVIA R Animas 10/4 0828 mx, ads (Montgomery-PA) ID?
 5004 RIO MUNI RN Batá 09/30 0524 SP tlk, Afr mx, fair (Newbury-NE)
 9/30 2014 Afropops, tlk, feature (Serra-ITALY)
 5005 NEPAL R Nepal 10/29 1150 TP 1215, tlk //7165.2 (Clark-ON)
 5010 CAMEROON R Garoua 10/15 2237 FR Afr mx, NA to 2258*(Frodge-MI2)
 5015 TURKMENISTAN Turkmen R 10/22 1820 vcls, flute, ID Gepleyar
 Asgabat (Ryan-THAILAND)
 5019.6 COLOMBIA Ecos del Atrato 10/8 0002 weak ID, poor mod (Terrence)

10/10 0215 HJ brassy ballads, ID, nice production (Jordan-PA)
 5020 NIGER LV du Sahel 10/23 2203* Koran, flute IS, chor (Brown-MO)
 10/11 2111 FR lcl mx, tlk (Klinck-NY) 10/11 2011 lang tlk, kids
 chant, FR DJ (Serra-ITALY)
 5020p SOL ISL SIBC 10/16 1105 EG nx, variety mx (Frodge-MI2)
 5025 BHUTAN BBS 10/29 1150 lcl mx, tlk o/Cuba (Clark-ON)
 5025v CUBA Rebelde 10/24 0140 sports coverage (Davenport-TN)
 5026 UGANDA NU 10/9 1900 EG nx, cmtry, vcels, xylo mx, NA (Ryan-THAI)
 5034.1 CENT AFR REP RTV 9/30 2005 FR Afropops, tlk (Serra-ITALY)
 10/19 0458 lang tlk, FR mx, nx & pops (Serra-ITALY)
 5035 BRAZIL Aparecida 10/17 0135 Stardust, Clapton, ID (Lamb-FL)
 5040 COLOMBIA LV de Yopal 10/29 2340 LA mx, ID (Terrence-NY) Tnx!
 10/4 0155 soft rock, ID 0300, good (Newbury-NE) 10/16 0318
 Padron... Colombiana, pgm w/Record, etc, HJPV (Flynn-OR) 11/7
 0420 LA & rock mx, IDs (Fair-TX)
 5040 ECUADOR LV del Upano 10/11 0200 upbeat mx, IDs, QTH (Jordan-PA)
 5047 TOGO Rdf Togolaise 10/22 2313 hilife mx, good (Brown-MO)
 10/7 2311 pops, FR DJ (Serra-ITALY)
 5049 ECUADOR R Jesús 11/5 0100 El Condor Pasa, etc, ID (Bickus-VA)
 11/14 2315 SP rel, Richard Clayderman piano, ID (Lamb-NY)
 5050 TANZANIA RT 10/28 *0329 ID, NA, brief EG nx, pops (Kohlbrenner)
 5060 UZBEKISTAN Tashkent 9/30 1959* mx, tlk, addr, ID (Serra-ITALY)
 5065 USA WWCW 11/6 1500* rel, ask for rpts, //9955 (Pappas-SD) 10/10
 1056 EG Brother Stair starts off 1st US stn to enter trop band
 (Montgomery-PA) 10/10 1301* EG preacher, IDs (Jordan-PA)
 5075 COLOMBIA Caracol 11/4 0541 SP IDs, tlks (Grenier-NV) 10/4 0837
 US pops, tlks, ads, fair (Montgomery-PA) 10/23 0446 mx, Caracol
 anmts, ment Colombia (Davenport-TN) 9/25 0530 Amanacer en
 America pgm, ref WRMI, fair, HJGC (Flynn-OR) 11/5 0121 hotel &
 bank ads, Xmas lotto, sports call-in pgm (Bickus-VA) 10/7 0437
 nx, IDs, ads (Serra-ITALY)
 5097.3 PERU R Eco 10/27 1046 SP tlk, OA mx (Klinck-NY)
 5620.9 PERU R Ilucán 11/16 to 0256* anmts, TC, flutes, ID (Pasz.)
 10/27 2258 NA? ID w/echo, tlks, poor (Kohlbrenner-PA) 10/30
 1103 rustic vcels, TCs, IDs, fair (D'Angelo-GP)
 5810 USA VOFC 10/22 2240 EG rel (WYFR), CH lessons, ID (Alexander)
 5810 USA KAIJ 11/14 0315 EG Gene Scott pgm, tnx Jones (Lamb-NY)
 5850 USA Monitoradio 10/12 0210 analysis of Iraq, exc (Newbury-NE)
 5860 CHINA Vo Jinling 11/15 1147 CH jazzy vcels, ID (Streitmatter-IN)
 10/31 1514 CH tlk, pres ID (Robertson-CA)
 5880 CHINA CPBS 10/31 1518 CH tlk, pres ID (Robertson-CA)
 5885 BRAZIL SRI Relay 10/10 0110 EG nx, ID, fair (Newbury-NE) 10/15
 0123 EG abt Swiss Army, Vatican QRM (Frodge-MI2)
 5894.7t PERU Paucartambo 11/7 0445 SP mx, vy weak (Fair-TX)
 5900 ISRAEL Kol Israel 10/29 1357 AR tlk, chant //9815 (Serra)

Eldon Electronics, Box 713, Port Coquitlam, BC V3B 6H9 Canada
 offers special loop antennas for AM broadcast band reception
 (540-1700 kHz) Also handles tubes. Write for price lists and
 description. Xmas sale saves money for Americans w/exchange
 rate.

MARIE, I see you and I found a couple of the same stations this time.
 DAVE CLARK's logs are the last from the "DX Barn" in Newmarket. Hopes
 to have a new setup by Xmas. Nice turnout this time. Thanks to every-
 one, newcomers and the old faithful. MARINA PAPPAS is working on her
 advanced class ham ticket. Her call is KBOMZZ.

This month reporters from 14 states again, 1 province & 2 countries.
 MARIE LAMB sent some logs from her brother's home in Seffner, FL.
 Merry Christmas to all - next deadline December 23.

Please support your favorite NASWA columns.



International Band Loggings

Wallace C. Treibel
357 N.E. 149th Street
Seattle, WA 98155

- 5920 CROATIA Croat R in CR 1120, orch mx, ID, folk chorus songs, //9830 (Serra ITALY 10/16)
5930 RUSSIA Murmansk R in RS/EG 1523, mostly RS, occas EG, ID (Robertson CA 10/30)
5940 RUSSIA V of Russia in EG 0220, new name for R Moscow, ID, nx, jazz, //7105 (Rausch NJ 11/3)
5950 RUSSIA RMI Petropavlovsk in EG/RS 1535, "RS for Business People", ID, IS (Robertson 10/31)
59808 GUATEMALA AWR Union R in SP 2340, Bible reading, ID (Rausch NJ 11/6)
6010 MEXICO R Mil in SP 0728, songs including "Thanks for the Memory", ID, f (Pappas SD 11/5)
6020 NETHERLANDS RN in EG 1945, nx, wx, ID during nx (Serra ITALY 10/11, Grenier NV 11/11)
6035 BELGIUM R Vlaanderen Int in EG 0036, Belg press review, ID, mail, pop mx (Tucker GA 10/2)
6070 CANADA CFRX Toronto in EG 0604, MW relay, local nx, wx, traffic rpts (Grenier NV 11/3)
6095 VATICAN STATE VR in SP 0330, church nx, sound bite of Pope, g (Lamb FL 10/25)
6110 PHILIPPINES VOA relay in EG 1634, nx in EG at slow speed, ID (Grenier NV 11/11)
6140 MOROCCO VOA relay in EG 0700*, ID, "VOA Sunday Morning", mx, ID, f-g (Lamb NY 11/6)
61498 THAILAND Amporn Sathan Or Sor in THAI 1130-1200*, non-stop vcls (Ryan THAI 10/25)
6155 SINGAPORE SBCC Radio One in EG 1500, pop mx, YL w/nx, ID (Grenier NV 11/3)
62352v DOMINICAN REPUBLIC R Quisqueya in SP 2255, uptempo LA mx, ID, QTH (Rausch NJ 11/12)
6560 IRAQ Rep of Iraq R in Kurdish? 0340, ID?, ezl & Iraqi amx, tlks, f w/QRM (Lamb NY 10/25)
7110 TIBET PBS Lhasa in lang 1300, IS, ID, tlks(nx?), lcl vcls, //4035 (Ryan THAILAND 10/5)
7125 RUSSIA R St Atlantika Murmansk in RS 0156, ID, nx?, disco bridge, tlks, f-g (Jordan PA 10/30)
7150 LITHUANIA R Vilnius in EG 0000, IS?, ID, QTH, nx?, classical mx, vp (Jordan PA 10/10)
7185 RUSSIA Golos Rossii in RS 2130, nx, tlk, mx bridge, IS, Kremlin chimes, ID (Ryan THAI 10/6)
7225 SOUTH AFRICA Channel Africa in PT *1958, IS, ID, TC, nx, African mx, f-g (Lamb NY 10/16)
7300 RUSSIA V of Russia in EG/SP 2258, instrml mx, ID, fqys, "Moscow Nights", IS, f (Lamb 10/31)
7370nf CROATIA Croat R in CR 0255, ezl mx, pips, ID, nx, CR pop mx, ex 7375, f (Lamb NY 11/9)
7375nf COSTA RICA TIAWR in SP 0314, relig tlk, classical mx, ID, QTH, //9725, f (Lamb NY 11/9)
7412 INDIA AIR in EG 1755, Hindu songs, ID, nx, //9950, 11620, f (Serra ITALY 10/24)
7415nf USA KVOH in SP/EG 0050, first day of bcst on new freq, relig pgm, ID (Rausch NJ 10/31)
7465 ISRAEL Kol Israel in SP 2206, nx, ID, QTH, romantic song, //7405, 9435 (Serra ITALY 10/22)
9022 IRAN VOIRI in EG 1928, IS, ID, NA, //11965, f-p (Serra ITALY 10/27)
9370 GUAM KSDA Adventist World R in EG 1527, ID, QTH, relig mx (Grenier NV 11/5)
9400usb COSTA RICA RFPI in EG 1749, "F.I.R.E." pgm, ID, sked, promo, f-g (Lamb FL 10/24)
9420 CZECH REPUBLIC R Prague in EG *1759, IS, ID, nx re CZ embassy in Angola, f (Lamb 10/24)
9435 ISRAEL Kol Israel in EG *2000, nx re bomb in Tel Aviv, Lebanon border, f-g (Jerris WV 10/21)
9480nf ARMENIA R Intercontinental in GM/lang 2205, speech, relig vcls, ID, fqy, QTH (Jordan PA 11/4)
9480nf ARMENIA Araks R Agency in EG/FR 2300, tones, IS, ID, lcl nx, into FR 2315, f (Jordan PA 11/4)
9535 JAPAN RJ Tokyo in EG 1404, University festivals & Halloween in Japan, ID, g (Pappas SD 11/5)
in EG 1733, ID, interview w/Korean YL contralto w/mx, into smx in JP 1800 (Robertson CA 10/11)
9580 YUGOSLAVIA RY Belgrade in EG 0111, Bosnian/Balkan nx, cmntry, ID (Tucker GA 11/1)
9620nf MOLDOVA R Dniester Int in EG 2130, ID, lcl upbeat vcls, farm rpts, p-vp (Jordan PA 10/9)
9645 COSTA RICA TIFC San Jose in SP 1327, relig tlk, ID, ezl mx, f w/het (Lamb FL 10/25)
9655 NEW ZEALAND RNZI in EG *1257, IS, ID, world nx (Rausch NJ 11/14)
9655nf COLOMBIA RN de Colombia in SP 1621, reactivated station, rock nx, nx, bells, ID, Colombian mx, slogan "para el pais y mundo", f-g (Lamb NY 10/24)
9670nf RWANDA Deut Welle relay in EG 1928, press review, election quiz, sports, African nx, "Monday Special", site ID in FR (Lamb FL 10/24) Note: This is a reactivated site after earlier closedown.
9690 SPAIN China R Intl relay in CH 0250*, nx?, tlks, mx clock, orch mx w/voice over (Jordan PA 11/9)
9700 BULGARIA RB in EG 2200-2300, IS, full EG sked, nx, rx mx, mailbag, f-g (Jordan PA 10/9)
9700 NEW ZEALAND RNZI in EG 0803, "Saturday Scrapbook", "Quote Unquote", g (Pappas SD 11/5)
in EG 0955-1100, multi-lang ID, pop mx, world/Pacific nx, exc (Jordan PA 11/9)
9710 MALI China R Intl relay in EG *0300-0400*, nx, jazz festival, mail, ID (Jordan PA, Tucker GA)
9720 SRILANKA SLBC in EG 1530, ID, pop mx, Melody Time w/classical mx, exc (Rausch NJ 11/13)
97202 ANGOLA V of the Resistance of the Black Cockrel in PT *0456, rooster & vibraphone IS, ID, QTH SW & MW fqys, polit tlk w/memts of UNITA & Angola (Rausch NJ 11/11)
9780 KAZAKHSTAN KR in RS 1315, folk ballads, ID, mentioned Alma Ata (Rausch NJ 11/14)
9820 CUBA RHC in EG 0343, "Dxers Unlimited" w/Arnie Coro, //6010 (Tucker GA 10/30)
9830usb/nf CUBA RHC in EG 0355, Cuban mx, IS, ID, fqys, "Tuesday Edition", f-g (Lamb NY 11/9)
9860 AUSTRALIA RA in EG 0652, lite mx, ID, IS, fqy, ancmts, pips, world nx, f (Serra ITALY 10/9)
9870 SAUDI ARABIA BSKSA in AR 2200-2301*, long discussions, 5+1 pips, ID, nx, f-g (Jordan 11/7)
9895 MADAGASCAR R Netherlands relay in EG 1352, ID, "Research File" (Rausch NJ 11/14)
9990 EGYPT R Cairo in IT 1834, "Vita Scientifica", ID, AR mx, f w/bd audio (Serra ITALY 10/17)
99351 GREECE RS Makedonias in GK 0835, GK folk mx w/lk after each song, ID (Serra ITALY 10/29)

- 9965 CHINA CRI Baoding in IT 1835, nx, wx rpt, ID, CH mx, lang lesson, //7470 (Serra ITALY 10/13)
- 10621nf? AUSTRALIA Aus Def Forces R in EG 1405, pop mx, tlk, ID, //8743, f (Serra ITALY 10/16)
- 110925usb ST. HELENA RSH in EG 2031, many call-ins & songs, p (Pappas SD 10/14) in EG 2231 f/in but very weak, ID(p), gone by 2300 (Robertson CA 10/14) f/in 2009, ID, QTH, refs to St Helena's specl annual day, tech details, p (Jordan PA 10/14) hrd 2015-2130, interview, het QRM, p (Hardester NC)
- 11515 CHINA CRI Beijing in CH 1803, M w/long monologue, ID 1829, f (Robertson CA 10/11)
- 11625 VATICAN STATE VR in EG 2017, church nx, ID, choral mx, "Reflection", IS, g (Lamb NY 10/16)
- 11650 FRENCH GUIANA Swiss R relay in FR/GM/IT *2215, polit & econ nx, pips, ID, f-g (Jordan 11/5)
- 11655 NETHERLANDS RN in EG 1744, "Newline", "Media Network" (Grenier NV 11/10)
- 11655 MADAGASCAR R Nederlands relay in EG 0049, "Newline", ID (Tucker GA 10/28) in EG 1950, nx w/correspondents, ID, feature pgm, //6020, 15315, 17605 (Serra ITALY 10/11)
- 11670 FRENCH GUIANA R France Int relay in SP 0130, L Am mx, ID, tlk in SP (Tucker GA 11/1)
- 11675 SEYCHELLES FEBA in Pushtu(p) *0228, IS, ID, Indian subcont mx, relig tlk, f (Lamb NY 10/25)
- 11740 GREECE VOA relay Kavalla in Amheric(p) 1834, nx, ID, IS, editorial?, f-g (Lamb FL 10/24)
- 11765 ASCENSION IS R Roma relay in IT 0230*, tlks, interviews, pop mx, ID (Jordan PA 11/1)
- 11770 PORTUGAL R Liberty relay in RS 1847, Clinton sound bites, ID, IS, nx, g (Lamb FL 10/24)
- 11775 SPAIN REE Madrid in EG 1901, lineup, ID, nx, SP pop mx, "Panorama", f w/QRM (Lamb FL)
- 11835nf THAILAND RT via VOA relay xmtr in EG 2030, natl nx, ID, fgy, QTH, pips, into Thai lang 2045 (Jordan PA 10/9) in GM/FR/EG/TH *2000, ID, nx on rejection US mil depot (Lamb NY 11/14)
- 11835 GREECE VOA relay Kavalla in Farsi(p) 1959*, IS, headlines, editorial, QTH, ID (Lamb NY 11/14)
- 11885 JAPAN RJ Tokyo in EG 0535, pgm re Halloween in Japan, ID, into JP 0600 (Rausch NJ 11/5)
- 11900 SOUTH AFRICA Channel Africa in EG 0519, pop song, business nx, ads, ID (Serra ITALY 10/7)
- 11965 IRAN VOIRI Teheran in EG 1930, NA, fgy, ID, tlk, chant, //9022, f (Serra ITALY 10/27)
- 11990 KUWAIT RK in EG 1935, pop mx, ID, pgm re Arab theaters, Koran (Serra ITALY, Jerris WV)
- 13605 RUSSIA Golos Rossii in EG 2100-2200*, 4-note IS, Kremlin bells, ID, nx, mx, features (Jordan PA)
- 13605 AUSTRALIA RA in CH *2200, s/on after Russia s/off, IS, tlks, nx?, ID (Jordan PA 10/21)
- 13615 BANGLADESH RB in EG 1235, vx, cmntry, mailbag, vocals, muddly modul (Ryan THAILAND)
- 13690nf? SWEDEN RS in EG 1856, discussion on Swedish vote whether to join EEC, g (Jerris WV 10/21)
- 13730 AUSTRIA RAI in EG 1250, "Report from Austria", ID, polit cmntry, class mx (Serra ITALY 10/29)
- 13750 INDIA AIR Aligarh in EG 1812, cmntry on US-N Korea tlks, g (Jerris WV 10/21)
- 15120 INDIA AIR Aligarh in EG 1330, nx, UN Radio pgm (Sats only) UN nx mag (Ryan THAILAND)
- 15200 GUAM KTRW TWR in EG 0806, relig sermon & mx, ID, QTH, f (Serra ITALY 10/29)
- 15320 UNITED ARAB EMIRATES Dubai in EG 1046, feature on Islam, ID, into AR 1055 (Serra ITALY)
- 15325 CANADA RCI Sackville in RS/EG 1825, tlk on sail racing, pop mx, ID, f (Robertson CA 10/10)
- 15325 BRAZIL R Gazeta in PT 2230, tlk re Brazil, nx, ID, political tlk (Paszkievich WI 10/14)
- 15335 MOROCCO R Marocaine in AR 1233, Moroccan mx w/tlk in AR, //15345 (Tucker GA 10/24)
- 15400 ASCENSION ISLAND BBC relay in EG 1836, "Focus on Africa", TC, ID (Serra ITALY 10/27)
- 15400 FINLAND RF in EG 1336, nx re the Baltic states, ID, g (Jerris WV 10/23)
- 154202 USA WRNO New Orleans in EG 1657, Rush Limbaugh, bad QRM (Hardester NC, Tucker GA)
- 15475 GABON Africa #1 in FR 1634, FR rap mx, US urban & gospel mx, ID, TC, f-g (Lamb NY 11/5)
- 15490nf ECUADOR HCJB Quito in EG 1703, L Am & world nx, ID, "DX Partylene", f-g (Lamb NY 11/5)
- 15625 PAKISTAN RP in EG 1101, internl nx, cricket & sports nx, ID, fgy, slo speed EG (Serra 10/14)
- 15640 ISRAEL Kol Israel in EG 1420, "DX Corner", ID, g-exc (Jerris WV 10/23)
- 17490usb ECUADOR HCJB Quito in EG 1306, relig pgms, //12005, 15115, f on 17490 (Pappas SD 11/6)
- 17605 NETHERLAND ANTILLES RN relay in EG 1954, feature mx pgm, //15315, 11655 (Serra ITALY)
- 17630 FRENCH GUIANA R France Int relay in FR 1815, football scores, ID, pops, nx, g (Lamb FL 10/27)
- 17750 BRAZIL R Nacional in PT 1810, BZ songs, political tlk, ID, slogan, QSB (Serra ITALY 10/28)
- 17785 MOROCCO VOA relay in FR 1825, nx re Clinton visit to M East, ID, remote rpt, f-g (Lamb FL)
- 17820 CANADA RCI in EG 1424, "Sunday Morning", story re US prison population (Tucker GA 10/30)
- 17860 RWANDA Deut Welle relay in FR 2000*, up-tempo mx, site ID, nx (Jordan PA 10/28)
- 17885 SEYCHELLES BBC relay in EG 0737, "The Jive Zone", ID, //15400, f-p (Serra ITALY 10/9)
- 18870 RUSSIA R Rossii in RS 1353, polit tlk w/ment of M Thatcher, pops, UK anthem, ID (Serra 10/15)
- 21520 GABON R France Int relay in FR 1103, nx, ID, pops, //15315, 17620, 17850, 21580 (Serra 10/16)
- 21580 PAKISTAN RP in EG/lang 0640, cricket match cmntry, muddly audio, //17560 (Ryan THAILAND)
- 21585 RUSSIA Golos Rossii in RS 0500, IS, Kremlin chimes, interlude mx, vcls, nx (Ryan 10/14)

CLANDESTINE STATION

- 9922v GUATEMALA La Voz del CID in SP 0100, typical polemics w/ments of Cuba & USA, station has been hrd also on 99245, 99208, and 99414, f w/slo fades (Jordan PA 10/29)

 No doubt you have noticed that this column is shorter than usual. I regret to inform you that the loggings sent to the Distribution Editor did not arrive at this QTH even though John Schmid mailed them ten days ago. Even via "Snail Mail" they should have been here within 5 days of mailing. I've kept my deadline for mailing to Bill Oliver several days past the usual time I allow for timely arrival in Pennsylvania but I had to finally go ahead with what material I had received directly. In order to meet the publishing deadline, Bill authorized me to send my columns via Express Mail so I hope they arrive on time despite the Thanksgiving holiday. Hopefully, the lost loggings will turn up

English Schedules

Tom Sundstrom

P.O. Box 2275

Vincentown, NJ 08088-2275

Fax: 609-859-3226

Internet: 2446376@mcimail.com

Genie: T.SUNDSTROM



Prepared 11/24/94 at 10:28 AM.

Thanks to Dr. Kim Elliott (VOA), Dan Ferguson (VOA), Jonathan Marks (RN), Dr. Adrian Peterson (AWR), and Andy Sennitt (WRTH).

Changes keep coming. On October 28 at 1158 UT, Radio Moscow changed its name to the Voice of Russia. After listening to Radio Moscow for the past 42 years, the new name surely sounds strange to me.



As reported on *Media Network* and *World of Radio*, on November 13 the VOA Bethany site closed for good and some of the Greenville transmitters were turned off. John Vodenik has been posting the gory details into the FidoNet Shortwave echo. The campaign to keep Bethany open and Greenville at full capacity unfortunately fell on deaf ears, even though the overseas sites continue to expand — at the risk of intervention by foreign governments and factions.

Via Kim Elliott, the new 30-minute *Communications World* on the VOA is now scheduled UT Saturday 1030, 1230, 1730, 2130 and UT Sunday 0030 (to the Caribbean). And Dan Ferguson and I figured out that R Ukraine is the culprit tearing up the VOA 03-04 on 7405. I found R Ukraine on parallel 5915. And Radio Moscow... err... Voice of Russia is competing very well with the VOA's "Daybreak Africa" on 7105 circa 03 UT.



All India Radio's outlet on 13750 to w&nAf at 1745 is surprisingly good here, second to 11620 (to wEu); at 1330 the GOS 13732 has been putting in a good signal.

R France Intl has added a half-hour of English to east Africa at 1700 UT. Heard on 9485 and 11700, the signals are quite readable here. As usual, frequencies aren't announced but I think



these are the only two of the set continuing from 16-17.

I can hear almost all of China R Intl's releases to Eu, Af, sPac and NAM. The 1200 UT 9655 to eNAM, announced, just cannot be heard through or underneath the Columbian on the frequency. If CRI is on another frequency in the 19, 22, 25 or 31m band, I can't find it even though there is good propagation; other CRI and Vietnam frequencies are heard well.



— Dr. Adrian Peterson advises that Adventist World Radio is starting a new DX program in January. The 15-minute *Wavescan* will replace all DX programs (e.g., DX Asiawaves) currently on the air from the different AWR stations. As logistics are worked out, the program will expand to a half hour. There will be four editions starting between January 1 and 15: Asian via KSDA: Sa 1515 and Su 1500 on 9370, Su 2315 on 11980. European via Slovakia: Su 0920 on 9450, Su 2120 on 6055. American: Sa 0100 via WRMI 9955, Sa 2000 via HRA 15675. The Latin American edition will air Sa on TIAWR, Su on TGMU; the air times are not known at the time we go to press. The program was originally to be called *Wavescan* but it seems that Larry Magne says that was a registered name to IBS Ltd, publishers of PWBR.

And Radio Sweden acknowledges "problems with 9850" so there have been tests on 9895 and, starting November 14, on 7120. These moves affect the 0230 and 0330 releases to NAM. So far 7120 produces the best signals of all, better than 49m that gets buried.



The VOIRI, Tehran, is on new 9670 (ex-11790) at 0030 and can be heard reasonably well in

PC Software by W2XQ

English Language SWBC Schedules Receiver Control: JRC, Kenwood, Lowe HF-150, Watkins-Johnson HF-1000 TRS Time for Windows™

Request a catalog from GILFER SHORTWAVE or download TRS_CAT.EXE from the Pics OnLine! BBS at (609) 753-2540. Type SWL at a main menu prompt. Get weekly updated full schedule and DX show data whenever you want it by making a 4 minute phone call; no cutting and pasting pages. See p.594 1994 WRTH.

TRS CONSULTANTS, PO Box 2275-NA, VINCENTOWN, NJ 08088-2275

parallel with 7100 and 9022. The 41m outlet clearly still provides the best signals of all here.



- With R Havana Cuba's start to NAM pushed back to 01 UT, Arnie Coro's *DXers Unlimited* has been retimed: UT Su 0230, 0430, 0630; UT We 0130, 0330, 0530. The other times are UT Sa and Tu at 2130 (Eu) and 2230 (Carib).

Spectrum's Monday repeat has been dropped per the November 7 program update from WWCR. The show has also been missing from WIFI-1460 Florence, NJ (northeast of Philadelphia, south of Trenton, about 8 miles north of me).

Speaking of medium wave, don't forget the next DX test from HCJB on 690 kHz. The test will take place UT December 24, 1994 from 0515 to 0545 UT. (That's late December 23 local time if you live in western North America and further west to the dateline.) Listen for more details on *DX Party Line* (to NAM UT Su 0109, 0509) and *The Latest Catch* (to NAM UT Th 0200, 0600).



catalog requests should be directed to Gilfer. If you visit the store, you can see our software in operation. The details:

Gilfer Shortwave
52 Park Avenue
Park Ridge, NJ 07656
800-GILFER-1 (orders only)
201-391-7887 (inquires/technical help)
201-391-7433 fax
Hours: Mo-Fr 10a-8p, Sa 10a-5p

A new software catalog may be downloaded from Genie's Radio RT or from Pics OnLine BBS. On the BBS, type SWL at a main menu prompt. Use the phone number best suited to your modem:

609-753-2540 - 9600-1200 Baud
609-753-2618 - V.32/V.42
609-753-2605 - 16.8k HST, V.32bis
609-753-1534 - 28.8k V.34, V.FC



The 1995 edition of the *World Radio TV Handbook* production has been going quite well, according to Andy Sennitt

and Bart Kuperus. By the time you read this it will have been delivered to the printer. Don't forget to order your copy now, as Gilfer Shortwave, Universal Radio and other SWL mail order houses should receive their shipments starting January 3.

Whatever holiday you celebrate, I wish you Seasons' Greetings.



GILFER SHORTWAVE

I am pleased to announce that Gilfer Shortwave — see their ad on the inside back cover — will be the exclusive dealer of our PC software. Our software includes the award-winning English language SCHEDULES program and receiver control software for the Japan Radio Company NRD-535, NRD-525, JST-135, the Kenwood R-5000, the Lowe HF-150, and the Watkins-Johnson HF-1000. Effective now, all orders and

Tom Swartz

SOLAR FLUX & A-INDEX: SEP-NOV 1994

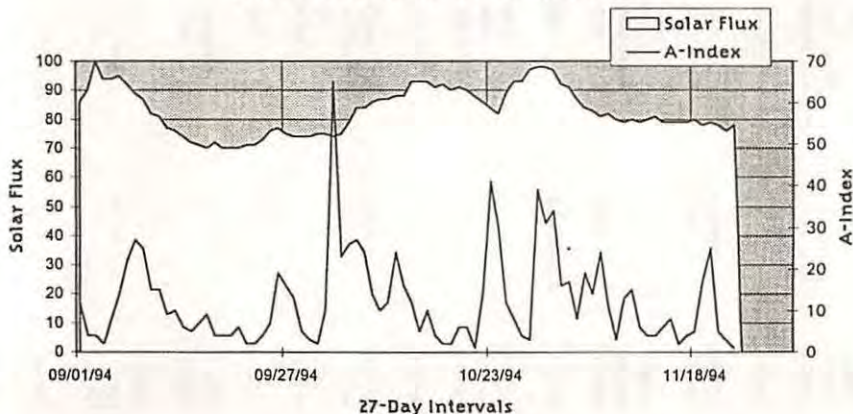

SCHEDULES

START END	COUNTRY	STATION	FREQUENCIES (kHz)	TARGET AREA	NOTES	LAST UPDATE
0000						
0055	China	R Int'l	11715 9710	eNAM		11/11/94
0100	USA	WFHA	9853	AU/Aus/6As	Mo-Sa	11/19/94
0030	Yugoslavia	R Yugoslavia	6185 6100	Eu		11/09/94
0030						
0130	Iran	V of Islamic Rep of Iran	9670 9022 7100	NAM		11/13/94
0300	USA	WRMI	9955	CAmr/Carib	Mo	11/05/94
0050						
0110	Italy	RAI	11800 9645	NAM		11/12/94
0100						
0200	Cuba	R Havana	9830U 6000	eNAM		11/07/94
0200	South Korea	R Korea	15575 7550	Am		11/19/94
0330	USA	WFHA	7465	AU/Eu/6As		11/19/94
0130	Yugoslavia	R Yugoslavia	9580 6195	eNAM	Mo-Sa	11/11/94
0130						
0140	Greece	V of Greece	9935 9420 7450	Aus/NAM		11/13/94
0200						
0500	Cuba	R Havana	9830U 9820 6000	eNAM/eNAM		11/07/94
1400	USA	KAUJ	9815 5810	NAM		11/05/94
0230	Yugoslavia	R Yugoslavia	6190	NAM		11/12/94
0230						
0300	Sweden	R Sweden	9850 6195	NAM	#1: testing 7120	11/16/94
0300						
0330	Mongolia	R Ulan Bator	12015 7290	NAM	Tu-We	11/14/94
0400	Russia	V of Russia	9850 7345 7105 5940	World Service		11/11/94
0400	USA	WSHB	9455	eAF		11/01/94
0330						
0400	Mongolia	R Ulan Bator	12000 7290	NAM	Fr-Su	11/14/94
0400	Sweden	R Sweden	9850 6200	NAM	#1: testing 7120	11/16/94
0340						
0350	Greece	V of Greece	9935 9420 7450	Aus/NAM		11/13/94
0400						
0455	China	R Int'l	9730	eNAM/wNAM		11/11/94
0500	Russia	V of Russia	9850 7345 7105 5940 5905	World Service		11/11/94
0500	USA	WSHB	9840	e&eAF		11/01/94

SCHEDULES

START END	COUNTRY	STATION	FREQUENCIES (kHz)	TARGET AREA	NOTES	LAST UPDATE
0500						
0555	China	R Int'l	9595	WNAm		11/05/94
0600						
0700	South Korea	R Korea	11945	WNAm		11/19/94
0640						
0820	Monaco	Trans World Radio	7120	UK	Sa-0835 Su-0845	11/02/94
0700						
0730	Georgia	R Georgia	11805	Eu		11/03/94
0745	Vatican State	Vatican Radio	15210 11740 9645 7250 6245 3945 1530 527	ME/EU/WCIS	Mo-Fri European 1st p	11/06/94
0800						
0900	N Mariana Is	KHBI	15665	eEu		11/01/94
1100	USA	WVHA	5850	Eu		11/19/94
0900						
1000	N Mariana Is	KHBI	9430	Japan/Kor/CIS		11/01/94
0910						
0940	Mongolia	R Ulan Bator	12000 7290	Aus		11/14/94
1000						
1100	N Mariana Is	KHBI	9430	China		11/01/94
1100	Russia	V of Russia	12015 11675	World Service		11/12/94
1100	USA	VOA	11915 9590 6165 930	Caribbean		11/22/94
1100						
1130	Georgia	R Georgia	11815	Eu		11/03/94
1200	N Mariana Is	KHBI	9355	Japan/Kor/CIS		11/01/94
1300	USA	WVHA	11695	Eu		11/19/94
1120						
1130	Vatican State	Vatican Radio	17585 15210 11740 6245 1530 527	neA/ME/Eu	Mo-Sa European 1st p	11/06/94
1200						
1255	China	China R Int'l	15440 11795	sPac		11/11/94
1300	France	R France Int'l	11840	seAs		11/12/94
1230	Mongolia	R Ulan Bator	12015 12000 7290	Pac	Mo, We, Th, Sa	11/14/94
1300						
1355	China	China R Int'l	15440	sPac		11/13/94
1400	N Mariana Is	KHBI	9355	India		11/01/94
1400	Russia	V of Russia	15560 15480 15470 15460 15320 12065 9875 9810 9540 7295	World Service		11/19/94
1400	USA	WVHA	11695	A/EU	Sa	11/19/94

SCHEDULES

START End	COUNTRY	STATION	FREQUENCIES (kHz)		TARGET AREA	NOTES	LAST Update
1330	Yugoslavia	R Yugoslavia	11865		Aus		11/16/94
1345	Vatican State	Vatican Radio	15585 11625		As/Aus/NZ		11/11/94
1400	France	R France Int'l	17560		ME		11/12/94
1500	N Mariana Is	KHBI	9355		India/China		11/01/94
1500	Russia	V of Russia	15560 15480 15465 15320	12065 12015 9875 9810	World Service		11/19/94
1500	South Korea	R Korea	11740 7275 5975		GOS		11/19/94
1500	USA	WWHA	15665 11695		A/EU	#1:Su-Tu-Th #2:Sa	11/19/94
1430	Portugal	R Portugal	21515		ME/FE	Mo-Fr	11/12/94
1445	Mongolia	R Ulan Bator	12000 7290		sAs		11/14/94
1500	China	China R Int'l	7405		wNAw		11/05/94
1600	Russia	V of Russia	15465 12065 12015		World Service		11/17/94
1700	USA	WWHA	15665		Eu	Su-Tu-Th-Sa	11/19/94
1600	France	R France Int'l	15530 12015 11700 11615 9485		AI		11/12/94
1700	South Korea	R Korea	9870 9525		ME/AI		11/19/94
0000	USA	KTBN	15590		eNAw		11/01/94
1620	Vatican State	Vatican Radio	11640 9500		eAI/As/Aus/NZ	SajMass	11/14/94
1700	China	China R Int'l	11575 9535 7405		eAs/AI		11/13/94
1730	France	R France Int'l	11700 9485		eAI		11/12/94
1800	N Mariana Is	KHBI	9355		eAI		11/01/94
1800	USA	WWHA	17613 15665		A/EU	#1:Mo-We-Fr #2:Su-Tu	11/19/94
1745	India	AIR	15075 13750 11935 11620 9950 9650 7412		GOS/eAs&AIw/Eu/ME		11/05/94
1800	Algeria	R Algiers Int'l	17745 11715 1422		Eu/ME/AI		11/05/94
2000	N Mariana Is	KHBI	9355		Eu/ME		11/01/94
2000	USA	WWHA	17613 9930		A/EU	#1:Mo-We-Fr #2:Su-Tu	11/19/94
1900	Yemen	Rep of Yemen R	9780		ME		11/24/94

SCHEDULES

START End	COUNTRY	STATION	FREQUENCIES (kHz)	TARGET AREA	NOTES	LAST Update
1900						
1930	Albania	R Tirana	9730 7260 1395	Eu		11/19/94
1955	China	China R Int'l	9440 6955	w&nAfr		11/12/94
2100	USA	WWCR	11970	Eu/NE/nA	tx #3	11/21/94
1930						
2030	Iran	V of Islamic Rep of Iran	9022 7260 1404	Eu		11/12/94
2000	Mongolia	R Ulan Bator	13650 7290	Eu		11/14/94
1945						
2000	Belarus	R Minsk	7210 7105 5940	Eu	Tu	11/02/94
2000						
2055	China	China R Int'l	15110 11715 9440	w&nAfr/e&sA		11/12/94
2015	Honduras	HRJA	15675	neNAm	Sa	11/10/94
2300	USA	WYHA	5850	Eu	Sa	11/19/94
2050						
2110	Vatican State	Vatican Radio	5882 3945 1530 527	Eu	European 1st ppm	11/06/94
2100						
2130	China	China R Int'l	15110 11715	w&nAfr/e&sA		11/12/94
2200	Cuba	R Havana	11720	Eu/Af/ME		11/07/94
2200	USA	WSHB	7425	eNAm		11/01/94
2200						
2300	Cuba	R Havana	6180	Carib&USA		11/07/94
2300	N Mariana Is	KHBI	9430	China		11/01/94
2300	USA	WSHB	13770	Brazil		11/01/94
2203						
2208	Croatia	Croatian Radio	9830 7370		News/English	11/15/94
2230						
2330	USA	WRMI	9955	C&Am/Carib	Sa	11/05/94
2300						
2400	N Mariana Is	KHBI	9430	China		11/01/94
2400	USA	WYHA	9853	Af/US		11/19/94

Solar Flux Monthly Hi-Lo-Average: 1978-1994

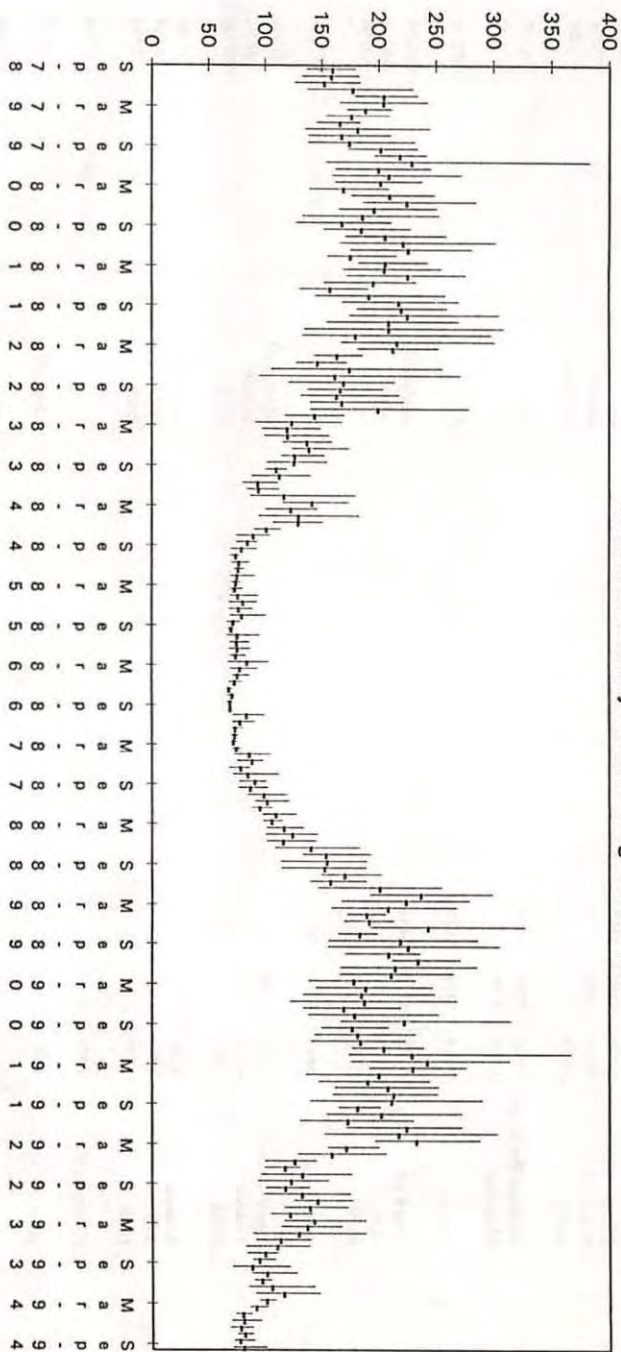

SOLAR FLUX & A-INDEX: AUG-OCT 1994

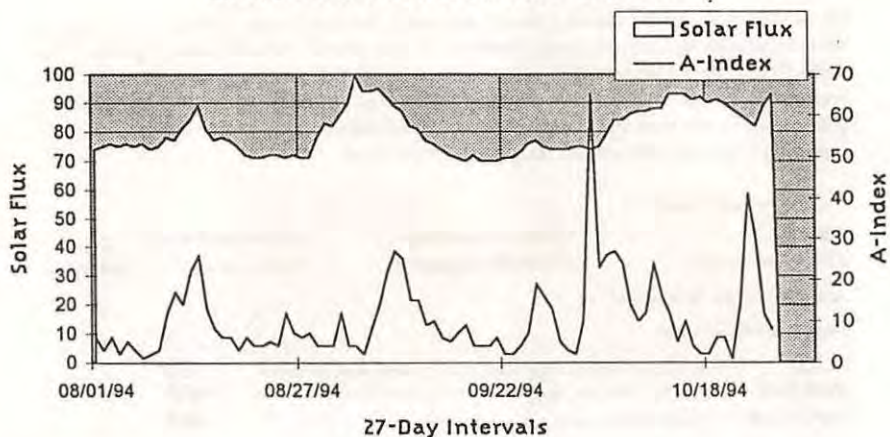

1994

SOLAR FLUX & A-INDEX: 1994

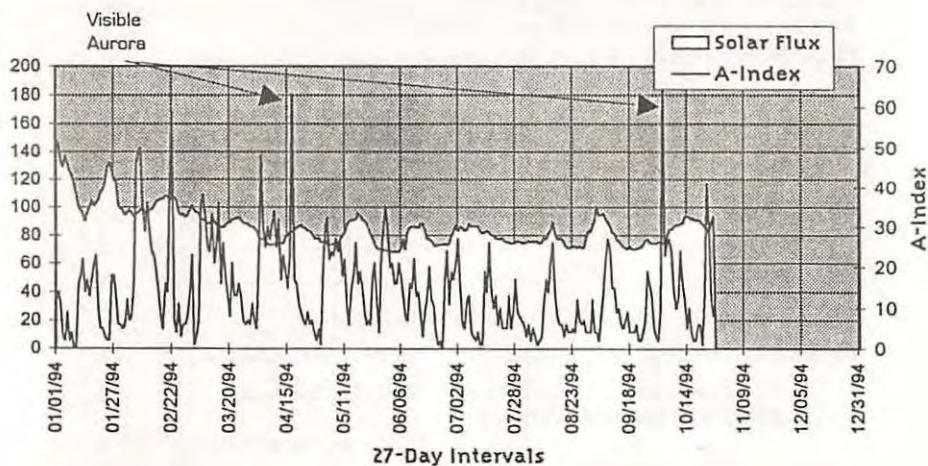

8th
Annual

Winter SWL Festival

March 16-18, 1994

Holiday Inn

Sumneytown Pike

Kulpsville, Pennsylvania

We will officially open the Eighth Annual Winter SWL Festival Forums on Friday morning and continue all day Saturday. As usual, there will be door prizes, station freebies, (please bring items to be donated for the silent auction), and a banquet on Saturday night. New this year, bring items for sale or swap for an equipment swap meet on Friday afternoon. Also new, bring your receivers and have their specs checked by two experts. Ben Hester and Joe Buch will report their findings and compare receiver specs in a forum.

The Forums will include:

- QSLing
- DX Accessories
- Intro to Scanning
- Pirate Broadcasts
- Intro to Utilities
- Interpreting Receiver Specs

And More To Be Announced...

Registration Options-

- FULL — Includes forums, hospitality room, lunch and banquet — \$35
PARTIAL — Includes forums, hospitality room but NO meals — \$17
SPOUSE — Includes hospitality room and meals — \$19

GRAND PRIZE To be announced

SPECIAL Register early and win a SW portable! Your registration received by midnight February 11, 1995 will allow you one FREE entry towards this early bird registration door prize.

Please bring items for the Silent Auction. Proceeds are donated to charity.

Checks should be made payable to WINTER SWL FEST. Registration for hotel rooms should be made directly to the Holiday Inn at (215) 368-3800 As soon as possible! Special rates - \$59 single, \$64 double. Our function code with the hotel is WINTER SWL FEST. Please refer to this to get the special room rates. Listen to the ANARC SWL NET on 7.240 LSB at 10 AM Sundays for up to the minute info.

The Holiday Inn is located at EXIT 31 of the PA Turnpike Northeast Extension-Lansdale Interchange. Improved access from the south with the Blue Route—ask for details. Limo service is available from Phila. Intl Airport directly to the Holiday Inn.

Please submit the following form with your registration amount or send for more information to:

Winter SWL Festival
PO Box 591
Colmar, PA 18915

Name _____

Address _____

City _____

Circle: FULL PARTIAL SPOUSE (Spouse Name: _____)

Banquet - Check: Roast Beef _____ Chicken _____ Registration Fee Enclosed: \$ _____

I wish to purchase _____ raffle tickets Tickets Fee Enclosed: \$ _____
(\$1 ea./ 6 for \$5/ Special 13 for \$10)

Total check/money order enclosed: \$ _____

Registration cancellations after 2/28/95 cannot be refunded, however we will refund raffle ticket money if you have to cancel.

FIRST IN SHORTWAVE

GILFER SHORTWAVE—AMERICA'S OLDEST SWL CENTER—INVITES YOU TO DISCOVER THE EXCITING WORLD OF INTERNATIONAL RADIO!

RF systems High quality, high performance antennas and accessories.



Magnetic Longwire Balun — Effectively isolates the antenna element from the coaxial feedline to reduce electrical noise.

MLB (Magnetic Longwire Balun only) \$59.95 (+\$4) Order #R02200
MLBA MK1 (12.5 meter longwire kit w/MLB) \$89.95 (+\$6) Order #R02201
MLBA MK2 (20 meter longwire kit w/MLB) \$109.95 (+\$6) Order #R02206

DX-7 Active Antenna (shown at left) — Compact helical HF receiving antenna covers 50 kHz — 35 MHz. Elliptical polarization helps minimize selective fading distortion. Mount indoors or outdoors.

DX-7 HF Active Receiving Antenna \$299.95 (+\$10) Order #R02207
IDX-7 Indoor Control Unit for DX-7 \$199.95 (+\$6) Order #R02209

Magnetic Transfer Antenna — A unique passive vertical antenna for outdoor use. Low noise and immune to the overloading problems that can plague active antennas, the MTA is perfect for users who do not have the real estate for longwire antennas. Only 7 feet tall, but covers 500 kHz — 30 MHz; special GMDSS version covers 100 kHz — 25 MHz.

Magnetic Transfer Ant. (Standard version) \$229.95 (+\$10) Order #R02202
Magnetic Transfer Ant. (GMDSS version) \$229.95 (+\$10) Order #R02205

T2FD & DX Listener Antennas — T2FD is a broadband, low noise tilted, terminated folded dipole covering 3 — 35 MHz. DX Listener is a T2FD with extra indoor control unit which allows antenna to receive down to 100 kHz. Antenna length just 45 ft.

T2FD Antenna \$239.95 (+\$10) Order #R02211
DX Listener Antenna \$389.95 (+\$10) Order #R02212

Also in stock: **DX-1PRO Active Antenna, SP-1 & SP-2S Antenna Splitters, and many other products from RF Systems!**

1995 WRTH BOOK SPECIALS!

1995 World Radio TV Handbook — All new and updated, this is the encyclopedia for radio and TV stations around the world. Includes frequencies, schedules, call signs, transmitter power, addresses and more! Reg. \$24.95

SPECIAL PRE-PUBLICATION PRICE: \$21.95 incl. shipping.

1995 WRTH Equipment Buyers Guide — From the staff of the WRTH comes the long awaited second edition of the book that tells it like it is about receivers, antennas and accessories. A perfect companion to the WRTH. Reg. \$24.95

SPECIAL PRE-PUBLICATION PRICE: \$21.95 incl. shipping.

Books sent via US Mail as soon as they become available from the publisher. For UPS delivery (faster!) add \$2.00 per book. NJ RESIDENTS PLEASE ADD 6% SALES TAX. Don't delay—Offer valid through 1/31/1995



NEW HOURS:
M-F 10am-8pm
Sat. 10am-5pm

GILFER
SHORTWAVE

52 Park Avenue
Park Ridge, NJ
07656

TOLL FREE ORDER LINE: (800) GILFER-1
NJ & Technical: (201) 391-7887 • Fax: (201) 391-7433

North American Shortwave Association
45 Wildflower Road
Levittown, Pennsylvania 19057

First Class Mail
U.S. Postage
PAID
Levittown, PA
Permit No. 319

FIRST CLASS MAIL



The Journal of the
North American Shortwave Association

ISSN 0160-1989

Executive Director: Richard A. D' Angelo, 2216
Burkey Dr., Wyomissing, PA 19610
Publisher / Business Manager: Bill Oliver, 45
Wildflower Road, Levittown, PA 19057
Executive Council: Jerry Berg, Ralph Brandi,
Bob Brown, Dr. Harold Cones, Rich D' Angelo,
Kris Field, Bill Oliver

EDITORIAL STAFF

Managing Editor: Bob Brown, KW3F
238 Cricklewood Circle, Lansdale, PA 19446
Desktop Publishing/Graphics: Ralph Brandi, 128
Greenoak Blvd., Middletown, NJ 07748
Shortwave Center: Hans Johnson, 7529 Red Cravat
Court, Columbia, MD 21046
Easy Listening: Richard Cuff, PO Box 4512,
Timonium, MD 21094-4512
NASWA Portraits: Jerry Klineck, 43 Lein Road,
West Seneca, NY 14224
Listener's Notebook: Al Quaglieri, P.O. Box 888,
Albany, NY 12201-0888; Chris Lobdell, P.O. Box
146, Stoneham, MA 02180-0146
Technical Topics: Joe Buch, N2JB, 2008 Mozart
Circle, Virginia Beach, VA 23454
QSL Report: Sam Barto, 47 Prospect Place,
Bristol, CT 06010
Distributing Editor: John Schmid, P.O. Box 86,
Line Lexington, PA 18932
Tropical Band Loggings: Sheryl Paszkiewicz, 1015
Green Street, Manitowoc, WI 54220
International Band Loggings: Wallace C. Treibel,
357 N.E. 149th St., Seattle, WA 98155

Scoreboard: Jerry Lineback, 6943 Parkway Dr.,
Douglasville, GA 30135
NASWA Awards: Dr. Harold Cones, 2 Whits Court,
Newport News, VA 23606
English Schedules: Tom Sundstrom, W2XQ
P.O. Box 2275, Vincentown, NJ 08088-2275
Listener's Library: Skip Arey, WB2GHA
P.O. Box 644, Waterford Works, NJ 08089
Destinations: Don Moore, 11434 140th St.,
Davenport, IA 52804-9538; Al Quaglieri,
P.O. Box 888, Albany, NY 12201-0888
Equipment Reviews: Alan Johnson, N4LUS
6001 Goldsboro Rd., Bethesda, MD 20817
The Company Store: Kris Field, 705 Gregory Dr.,
Horsham, PA 19044
MEMBERSHIP FEES:
North America (First Class Mail) \$25.00
Overseas
Central America, Caribbean, Venezuela
& Colombia \$29.00
South America and Europe \$29.00
Asia, Africa and Pacific \$32.00

All remittances must be in U.S. funds and mailed to:

NASWA
45 Wildflower Road
Levittown, PA 19057
U.S.A.

