

NASA

the JOURNAL

NORTH AMERICAN SHORTWAVE ASSOCIATION

Volume XXXIII, Number 3

March, 1993

50 VOICE OF AMERICA
YEARS OF BROADCASTING TO THE WORLD
1942 - 1992

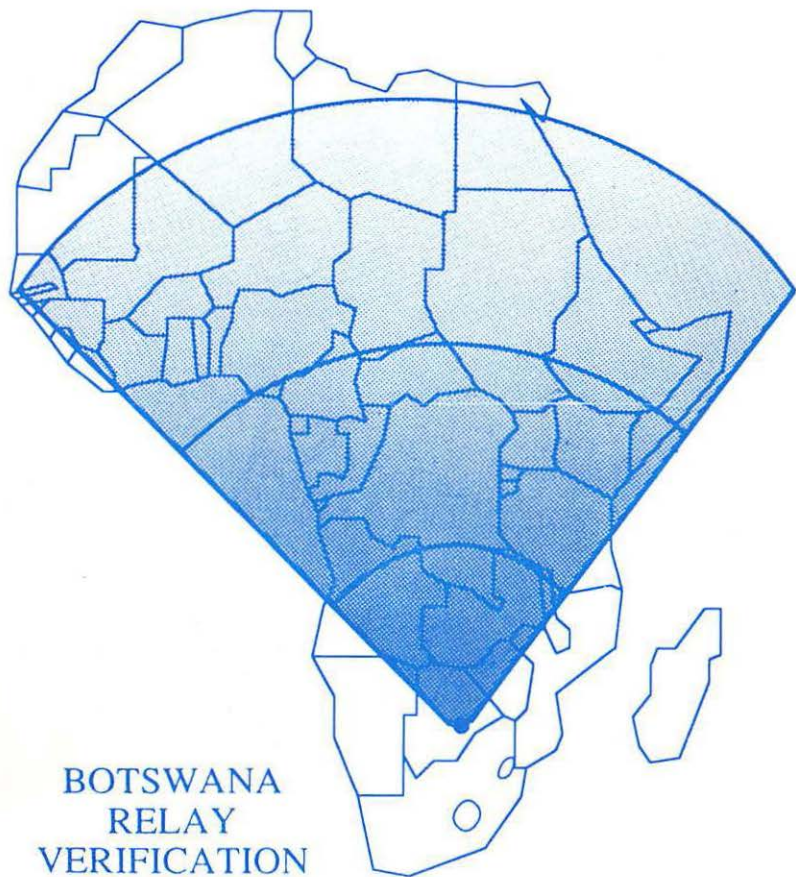

BOTSWANA
RELAY
VERIFICATION

New Arrivals at Universal Radio!

YAESU

FRG-100



The new Yaesu FRG-100 receiver provides the performance of a quality communications receiver at an affordable price. It provides solid coverage from 50 kHz to 30 MHz in CW, SSB and AM modes (FM mode with optional #0816). The latest microprocessor technology is used to merge performance and reliability with easy operation and functional simplicity. The FRG-100 incorporates features that both the casual and serious shortwave listeners will appreciate. Reception modes and most receiver functions are push-button selectable from the front panel. A crisp back-lit LCD with adjustable brightness provides frequency read-out and important operational status at a single glance. Selectable tuning steps of 10 Hz, 100 Hz and 1 kHz are standard, with other tuning steps programmable by the user. Fifty tunable memories store frequency, mode and filter information. Two additional memories provide band-edge information used for scanning. The FRG-100 has programmable 12/24 hour clocks and sleep timers to enable you to automatically switch the receiver on/off to record your favorite broadcasts. Multi-function scanning (memory, band, selectable group or priority) with carrier or time-delay is supported. A special broadcast band mode enables convenient setting of 16 pre-programmed international broadcast bands. The FRG-100's adjustable SSB carrier offset permits you to custom tailor the receiver's audio response. CW enthusiasts will enjoy the reverse BFO offset and selectable CW sideband. Installation of the 250 or 500 Hz narrow filter further enhances CW reception and interference rejection. Other features include adjustable AGC, RF attenuator, noise blanker, all-mode squelch, and signal strength meter. The Yaesu CAT system provides a direct link to the CPU in the FRG-100, allowing a personal computer with the optional Yaesu FIF CAT interface. This can provide computer controlled customized scanning and remote control of most receiver functions. Other options include: TCXO-4 Hi-Stability Osc, FM-100, and CW filters.

SPECIFICATIONS

Dimensions	9" W x 3 6" H x 9 3"
Weight	6.6 Lbs. (9 Lbs. ship)
Frequency Range	50 - 30000 kHz
Power	11-13.5 VDC 1.2A
Antenna Impedance	50 or 450 ohm
Selectivity (-6dB)	AM-W 6.0 kHz AM-N 4.0 kHz SSB/CW 2.4 kHz FM (opt.) 15.0 kHz
Sensitivity	< 25 μ V 1.8-30 MHz SSB < 1 μ V 1.8-30 MHz AM (S+N/N=10dB)
Freq. Stability	< \pm 10 p.p.m. 0-50°C
Intermediate Freqs.	1st IF = 47.21 MHz 2nd IF = 455 kHz
Audio Output	1.4 Watts at 8 Ohms
Squelch Sensitivity	< 2 μ V 1.8-30 MHz (CW, SSB, AM) < 32 μ V 28-30 MHz (FM)
IF Rejection	> 70 dB (1.8-30 MHz)
Image Rejection	> 60 dB (1.8-30 MHz)
Standard Steps	10Hz/100Hz CW/SSB 100Hz/1kHz AM/FM
Circuit Type	Dual Conv Superhet

FRG-100 List Price \$599.00
FRG-100 Discount Price
 Order #2786 **\$549.95 (-\$49)**

Quality US
Tech

8A



The World Access Radio model 8A was completely designed and built in the United States. Over 75% of the total dollar value of the components are made in America. This continuous coverage, LED digital receiver tunes 100 kHz to 30 MHz to include longwave, medium wave and all of shortwave. The 8A also receives the FM broadcast band! The dual conversion circuit provides good sensitivity and image rejection. A 7 kHz bandwidth is supplied. You can tune the 8A with the manual tuning knob or by the built-in keypad. Shortwave tuning resolution is user selectable at 1 or 5 kHz. Sixty non-volatile memories store frequency and band (AM/FM or SW). The 8A can band scan or scan presets. It has a telescopic antenna plus you can also attach a long wire antenna for extra pulling power on FM and shortwave. A full featured (12 or 24 hour) clock-timer circuit is featured with a 12 event timer. A rear mounted DIN jack is provided for record-out and recorder activation. The 8A comes with a power adapter (115VAC to 9 VAC) and is ready to play. In attractive light oak wood-like grain cabinet. Optional wood cabinets available soon. 12" W x 7" H x 5" D.

World Access Radio 8A

List \$289.95

Order #1483

\$239.95 (+\$6)

WORLD RADIO TV HANDBOOK 1993 Edition

Considered the SWL's Bible with schedules, frequencies and addresses of shortwave broadcast stations. Organized primarily by country. Also includes a by-frequency listing of SWBC stations. 47th Ed. ©1993 Billboard. 270 p.
 Order #2000 \$19.95 (+\$1 shipping)

THE 1993 WRTH EQUIPMENT BUYERS GUIDE

By W. Bos & J. Marks. A complete and objective buyer's guide to the current shortwave receiver market. Designed for the new or experienced worldband listener. Coverage includes portables and communications receivers, plus antennas, auto units and computer control software. ©1993 Billboard. 270 p.
 Order #1993 \$19.95 (+\$1 shipping)

DISCOVER DXING! - AN INTRODUCTION TO TV, FM AND AM DXING

By John Zondlo. This book provides a readable introduction into DXing AM, FM and TV. Topics include: propagation, seasonal conditions, equipment, antennas and reference materials. There is an excellent section on "best bets" for hearing fifty states on AM. ©1992 Universal Radio Research.
 Order #0010 \$4.95 (+\$1 shipping)

➤ **HUGE 1993 catalog available on request!**
 ➤ **Used Equipment List available on request!**

SANGEAN

ANT-60

The Sangean ANT-60 portable "roll-up" shortwave antenna will improve the reception of any portable worldband receiver. The antenna wire may be extended up to 23 feet (7 m). Unlike other reel antennas, the ANT-60 terminates with a mini-plug. (3.5 mm). This will plug into the external antenna jack of most portables. If your receiver does not have a mini external antenna jack, an adapter plug is provided to clip the ANT-60 to your telescopic whip. Works with all brands of portable radios.

Sangean ANT-60

List \$15.95

Order #3184

\$10.95 (+\$3)



Universal Radio, Inc.
 6830 Americana Pkwy.
 Reynoldsburg, Ohio
 43068 U.S.A.

➤ 800 431-3939 Orders
 ➤ 614 866-4267 Info.
 ➤ 614 866-2339 FAX

NASWA Notes

Bob Brown KW3F
238 Cricklewood Circle
Lansdale, PA 19446
CompuServe 74756,1557
GEnie R.BROWN106
Packet KW3F @ WB3JOE



Hi Gang! Please excuse the abbreviated column this month. The Brown family is on vacation. It was a great Fest! I'll be back next month with all the details.

Welcome to the following new NASWA members -

- | | |
|---------------------------------------|---|
| James Earl Barker III, Washington, DC | Stephen Levick, Philadelphia, PA |
| Jon Bevilacqua, Queens, NY | Theodore K. Martin, Petersburg, IL |
| Bruce W. Churchill, Escondido, CA | Edward P. Muro III, N. Woodmere, NY |
| Joe DiLeo, Waterbury, CT | Francisco Orosco, Oakland, CA |
| Ralph Dunham, Yorba Linda, CA | Mike Parrish, Paris, KY |
| Richard T. Eddie, St. Louis, MO | Bill Petkoglou, Toronto, ONTARIO |
| George Farah, Punchbowl, NSW, | Reggie G. Pruitt, Shelby, NC |
| AUSTRALIA | Jeff Reichl, Jonestown, PA |
| Tony Germanotta, Chesapeake, VA | David Ringold, Hamden, CT |
| Donald M. Getzug, Vista, CA | Jon Schwartz, Mercer Island, WA |
| Carolyn Gritzmaker, Maypearl, TX | Maurice Smith, West Sacramento, CA |
| John Harmicar III, Youngstown, OH | Don Storms, Riverdale, GA |
| Robert J. Hill, Burlington, MA | Paul J. Tooker, Babylon, NY |
| Dwight A. Keen, Fair Grove, MO | Chris Tyle, New Orleans, LA |
| Fred Kleppick, Pittsburgh, PA | Alexander Vargas, San Diego DelAlcala, CA |
| Daniel Koutalakis, W. Springfield, MA | Kenneth J. Villone, Conesus, NY |
| A. J. Lambert, Highlands North, | Charles Vollmer, St. Charles, MO |
| REP. S. AFRICA | S. Wild, Queens Village, NY |
| Gustavo Leidhold, San Salvador, | |
| ARGENTINA | |

Calendar Of Events

- Mar 5 - Meeting, Boston Area NASWA Chapter, GTE Labs, Waltham, Mass. 7:30 PM For additional information please contact Paul Graveline (508) 470-1971, or via modem on Tom's BBS, (617) 698-8649 (300/1200/2400 baud), (617) 698-8734 (9600).
- Mar 7 - The Tidewater SWLs meet on the first Sunday of each month at 6:30 PM. Location is the Steak & Ale Restaurant, 5764 Virginia Beach Blvd. (corner of Va. Beach Blvd. and Military Hwy.), Virginia Beach, VA. For info, call Joe Buch, (804) 721-2782.
- Mar 16 - Meeting, N.E. Ohio SWLs. Cuyahoga County Library, 9089 Brecksville Rd., Brecksville, OH (Rt. 21, just South of Rt. 82). 7:00 PM. For info send SASE to: NE Ohio SWLs, c/o Donald J. Weber, P.O. Box 652, Westlake, OH 44145-0652
- Mar 19 - Meeting, Philadelphia Area NASWA Chapter. Kulpville Holiday Inn, Kulpville, PA. 7:30 PM Contact Dan Cashin (215)446-7831
- Mar 20 - The Miami Valley DX Club (All band orientation) meets on the third Saturday of each month at 1 PM. Locations vary but are announced in advance. For info, call the MVDXC (614) 471-9973 Or, send a SASE to MVDXC, Box 292132, Columbus, OH 43229-8132

Members are invited to submit items to be included in this calendar to Bob Brown.

Our Motto is - "Unity and Friendship"

Easy Listening

Richard D. Cuff
213 Parkview Avenue
Allentown, PA 18104-5323
GENie R.CUFF
MCI Mail 375-4854
CompuServe 71207,1604
Prodigy NCHT70A

If You Weren't There, You Missed A Great Time

The Sixth (!) Annual Winter SWL Festival is now history, as another good time was had by all in Kulpsville, PA. It was great to talk to many folks who read the Easy Listening column each month. Thanks for the words of encouragement - they do help!

It was also a lot of fun to present a forum on Easy Listening. I know I barely scratched the surface of the world of Easy Listening, but the information seemed to be well received.

Let's see...how many more days until the Seventh (!) Annual 'Fest....

Radio Japan Expands Relays to North America

Joe Hanlon tipped me off to this at the 'Fest, and Sheldon Harvey provided me with the Radio Canada International (RCI) engineering schedule that corroborates the tipoff: Radio Japan will double its use of RCI relays to North America as of April 1st. The additional hours will be 0400 - 0600 and 1300 - 1500 UTC. NHK's existing 0100 - 0300 (0200 - 0400 when Daylight time becomes effective April 4th) and 1000 - 1200 (1100 - 1300 summers) relays will continue.

Provided Radio Japan doesn't change its schedules, and provided the relay continues to feed the General Service, English broadcasts will be heard from 0500 to 0600 and from 1400 to 1500 UTC. Frequencies are shown as 9725 for the 0400 relay, and 11735 for the 1400 relay.

As for programs, I'm working off the November - January schedule. I don't know if there any changes took effect in February; I'll try to update the schedule as needed. Both the 0500 and 1400 use the same program cycle, and this cycle differs from the 0100/0300 and 1100

releases.

This includes some programs not previously heard in the North American relays, and I'll have some program details in the May *Journal*.

BBC World Service Highlights

March continues the World Service's Spotlight on South Asia, with features on the region's politics, music, language, religion, books, conversation, women, the military, tigers, and tourism.

John Figliozzi reminded me at the 'Fest that, even when particular series run their course, their replacements are normally courses from the same genre. For example, new quiz shows replace old quiz shows that have finished their run.

News and Features

Regular feature: From The Weeklies surveys the British newsweekly publications. Like the American newsweeklies *Time* and *Newsweek*, the British newsweeklies step back a bit and analyze the factors behind the week's news. Perhaps the most famous British newsweekly is *The Economist*. From the Weeklies airs Saturdays 0030, 1045, and 1945.

Mondays beginning March 2nd, 2315 - Sparks from a Precious Stone profiles women from several walks of South Asian life and examines the challenges facing women in these societies today. You'll meet a policewoman, a journalist, a doctor, and a unionist during this six-part series. Repeated Tuesdays at 0445 and 0930.

Sundays beginning March 14th, 0415 - India's Children of Courage is a new installment of the popular *Children of Courage* which premiered

Radio Japan Program Notes

:00 - :15 News

:15 - :50 Radio Japan Magazine Hour, with
 In Conversation, Let's Practice Japanese (Mondays)
 Asian Hotline, Environment Update (Tuesdays)
 Japan Close-up, People (Wednesdays)
 Travelog, Story Reading, Book Trends (Thursdays)
 Music Mix (Fridays)

:50 - :55 Commentary

:55 - :00 Tokyo Pop In

Weekend programming differs slightly:

:00 - :15 News

:15 - :00 This Week (Saturdays)

:15 - :55 Hello from Tokyo, Radio Japan Guide (Sundays)

:55 - :00 Viewpoint (Sundays)

last year. This four-part series focuses on the Indian Council on Child Welfare and its awards for gallantry. In addition to the awards, college scholarships are provided. You'll hear stories about hyenas, leopards, and bandits. Repeated Mondays 1930, Tuesdays 0915.

Monday, March 15th, 0101 - **It's All A Plot** traces the historical origins of conspiracy theory and examines why conspiracy theory is so captivating. According to conspiracy theorist Mary Seal, an elite group of 300 people, capable of causing earthquakes and rainstorms at will, seek to wipe out the middle class and control the planet by controlling banks, oil companies, and pharmaceutical companies. Then there's the JFK conspiracy... Repeated 1515; also airs Saturday March 13th at 1901.

Wednesdays, beginning March 17th, 0130 - **A Bad Press?** looks at the way so-called "villains of history" were profiled over the years, and considers how their reputations may have been unjustly tainted. While King Richard III of England has long been considered particularly ruthless, the succeeding monarch Henry VII displayed similar ruthlessness but was never vilified as much as his predecessor. Sir Francis Drake, for instance, is seen as a naval hero in England, but as an ogre in Spain and Latin America. Repeated 0930 and 1715.

Friday, March 19th, 1230 - **Paradise for Some?** **Tourism in South Asia** is a program looking at the stresses on the indigent developing economy caused by the influx of tourists to Indian coastal

resorts, motivated by the tropical weather. Lands are being converted into resorts; water is diverted from farming to hotels. (Sounds somewhat like issues in Mexico here in North America). Also airs 0730 and 1930 the same day.

Monday, March 22nd, 0101 - **Marking Time** profiles John Harrison, who 300 years ago developed the first clock that could keep accurate time at sea for months on end. The technology greatly expanded overseas trade and facilitated military campaigns. Martin Redfern creates a dramatic account of Harrison from notes and records from the period, focusing on his work and his struggle for recognition. Repeated 1515; also airs Saturday, March 20th at 1901.

Friday, March 26th, 1230 - **Sustainable Technology** looks at some of the quirks of Indian business that seem to perpetuate technologies that have long since been jettisoned elsewhere. For instance, spare parts for the 1950s automobiles Morris Minor and the Royal Endfield Bullet are still made in India, and a large number of the cars are still on the road today. Other Indian technologies - fuel-efficient stoves, hydroelectric generators, and microelectronics (in Bangalore) are also profiled. Also airs 0730 and 1930 the same day.

Sunday, March 28th, 1401 - **Heritage** is a new five-part series looking at issues of cultural and historical heritage in a variety of locales. On its debut Sunday, the program looks at the risks posed to historic buildings in Kathmandu, Nepal. The population explosion, unchecked development, and

poverty all conspire to threaten historic structures in the city. Repeated Mondays 0630 and 1001.

Music/The Arts

Regular feature: *A Taste of Soul* features a mix of jazz, gospel, pop, and blues. Robbie Vincent hosts. Airs Sundays, 0445, with repeats Mondays 1445 and Wednesdays 0815.

Mondays, beginning March 8th, 2215 - Indian film songs have become the pop music of South Asia, and the six-part series *Music for the Millions* traces the development of the most popular form - Hindi film music. The distribution of movies in the South Asian region has helped this musical form become dominant. If you're a fan of South Asian music, check it out. Repeated Tuesdays 0630, Wednesdays 1615, and Fridays 1030.

Monday, March 22nd, 0101 - *Images of Debussy* marks the 75th anniversary of the composer's death by looking at Debussy's work and how he used orchestral color and sonority to evoke a feeling similar to the play of light on waves. Debussy claimed he was searching for ways to reach "the dream within the dream". Debussy is profiled by Michael Berkeley. Repeated Monday 1515; also airs Saturday 1901.

Fridays, beginning April 2nd, 0030 - *In the Steps of Rachmaninoff* profiles the life and career of the Russian composer on the occasion of the 50th anniversary of Rachmaninoff's death. The six-part series looks at Rachmaninoff's music and visits places familiar to Rachmaninoff and people who knew him. Repeated at 1715 UTC; also airs Tuesdays at 1030.

Drama

Fridays beginning March 5th, 0230 - *The Man In Black* features the spine-chilling short stories told by Edward de Souza; *Green and Pleasant* on the 12th by Bert Coules tells of a man kidnapping a rock star to teach her a lesson about the environment; *Dead Man's Boots* by William Ingram on the 19th that looks at a bargain home purchased and how the purchasers received more than they bargained for. Also airs Thursdays at 1130 and 1715.

Sunday, March 14th, 0101 - *Play of the Week* features *The Hole in the Top of the World*, written by Briton Fay Weldon. What's unusual is that this was recorded in Los Angeles with an all-American cast, including Walter Matthau, Valerie Lansbergh, and Barbara Bain. *The Hole in the Top of the World* is about a scientist (Matthau) stationed in Antarctica and torn between his young, attractive research assistant (Lansbergh) and his ex-wife (Bain).

ZAP!!

Oh well...I inadvertently touched the antenna of my beloved Sangean ATS-803 while I had a static charge, and the radio went deaf in the shortwave bands. The column is a bit short this month due to my lack of a decent radio, but the situation should be rectified in time for next month.

Until then,

73 DE Richard

NOTICE PLEASE

SINCE WE HAVE A LITTLE SPACE TO FILL HERE, IT MIGHT BE A GOOD IDEA TO REVIEW THE GUIDE FOR ADS FROM MEMBERS. NASWA WILL PRINT ALL SUCH ADS PROVIDING SPACE IS AVAILABLE AT NO CHARGE. SEND YOUR ADS TO NASWA, 45 WILDFLOWER ROAD, LEVITTOWN, PA 19057. IF YOU DON'T TYPE, PLEASE BE SURE THAT THE AD IS LEGIBLE. WE CANNOT RUN ADS FOR MORE THAN ONE MONTH AT A TIME. A REPEAT AD HAS TO SENT AGAIN. THIS IS TO AVOID USING SPACE TO ADVERTISE ITEMS THAT HAVE ALREADY BEEN SOLD. IF THE ITEM IS FOR SALE, PLEASE SPECIFY WHO IS TO PAY THE POSTAGE INVOLVED.

DON HOLGER AND RADIO ZARACAY

By Don Moore

Mention the country of Ecuador to a shortwave listener, and the probable response will be about HCJB and the high Andes mountains. Although The Voice of the Andes does overshadow everything else in the country, (at least to DXers!), Ecuador is home to dozens of smaller shortwave broadcasters. For years, one of the easiest to hear was Radio Zaracay on 3395 khz in Santo Domingo. About two years ago Radio Zaracay sold its shortwave transmitter to the Santo Domingo branch of Ecuador's Radio Catolica branch. Radio Zaracay plans to concentrate on its FM service, which is the most popular radio station in Ecuador today. Radio Zaracay may not be on SW anymore, but it is very typical of many modest sized Latin American stations so let's take an in-depth look at the station.

SANTO DOMINGO

About halfway between Quito and the Pacific Ocean lies Santo Domingo. The Andes mountains are miles away - this is Ecuador's flat low coastal plain - banana and sugar cane country. Originally an agricultural center, today Santo Domingo is one of the boom towns of Ecuador because of its importance as a transportation center. The city is on the midpoint of the Quito-Guayaquil highway, linking Ecuador's two largest cities and other paved highways run to the port of Esmeraldas, on the north coast, and the fields of Manabi province to the west.

The official name of the city is Santo Domingo de los Colorados. Los Colorados refers to the Colorado

Indians, who have lived in this region for hundreds of years. Once they were in the majority here, but today the few thousand Indians are a minority in their homeland. But, unlike many indigenous groups, they have political and economic power far greater than their numbers might indicate. The tribe is very well organized, and elects its own governor and council, who watch out for the tribe's interests. Most of the Indians own prosperous small farms along tropical streams outside Santo Domingo.

The Colorados are easily recognizable by the mens' traditional dress: a striped cloth wrapped around the waist, and hair dyed and molded flat with a paste made out of achiote (paprika). A Colorado witch doctor was pictured on HCJB's March-April, 1984 QSL card. A local joke is that the Indians do this so that they can season their food by shaking their head over it.

RADIO ZARACAY

In early 1985, my wife and I visited Santo Domingo while spending several weeks in Ecuador so that I could visit Radio Zaracay. Finding the station was no problem; I spotted it on the bus coming into town. Radio Zaracay is in a six story building, one of the city's tallest, and there is huge sign which can be seen all over the downtown on the roof. After we checked into a cheap pension, I made my way to the station's offices on the sixth floor of their building and explained my interests as a visiting DXer to the secretary. She ushered me back a long hall to the entrance to a small studio.

Station owner/manager Don

Holger Velastegui was busy reading the afternoon comunicados. When he was done, the secretary introduced me, and Don Holger invited me into his office. His office walls were paneled and covered with plaques and certificates that the station had received over the years. And on one side, near the ceiling, were two stickers. One was for "WRSC Radio 1390" in State College, PA, and the other for the Nittany Lion football team of Penn State, in the same city. I almost dropped over. I had sent those to the station a few years earlier, along with a reception report. Nothing else from overseas listeners was to be seen, only the stickers I had sent. It was an unbelievable coincidence.

RADIO ZARACAY

Don Holger talked endlessly about the station and gave me a great tour. Radio Zaracay uses the top four floors of the building. That's more room than they really need, so the offices and studios are huge. The studios are among the most modern in Ecuador. The first floor is rented out to small shops, and Don Holger's family lives on the second floor. With the boss so close, no one better be late for work! The programming on Radio Zaracay is typical of many Ecuadorian broadcasters, although it is probably more professionally done than most. Music, especially Ecuadorian folk music, forms the bulk of the programming. Otherwise, the station broadcasts news, sports, advertisements, and local announcements.

One of the most unusual aspects of Ecuadorian radio, to a *gringo* is how provincial Ecuadorian stations like Radio Zaracay get their news. In North America, listeners are accustomed to hearing late-breaking news on the radio. Daily newspaper provide background details, but it's the radio that keeps people up-to-date. In Ecuador, it's a little different. Provincial stations don't broadcast national and international news until the daily newspapers from Quito and Guayaquil arrive. Then the

papers are rushed to the studio, and the announcer leafs through the paper, reading headlines and summarizing major stories for listeners.

Unusual, yes. But, that doesn't mean there aren't good reasons. Small radio stations in Ecuador can't afford to subscribe to wire services, even if they are available. The only alternative would be to continuously monitor the major stations in the capital, or the big international broadcasters on SW. That is done during a crisis but, on a day-to-day basis, it's time consuming.

The newspapers don't mind, since people still buy the papers, to read the articles more in-depth, or maybe just to look at the ads. Most who don't buy the papers, have very good reasons for not doing so. About forty percent of the population is illiterate. Obviously, they're not going to buy a paper. Also, Ecuador has no rural delivery, so people in small villages and farms can't buy a paper unless they make a trip into town.

At Radio Zaracay, the first morning newscast is taken from the pages of Quito's "El Comercio", and read by Don Holger. In fact, it's a tradition, and Don Holger has a story showing it may have become more of a tradition than he ever imagined. Once on a flight to the Galapagos, he wasn't feeling well, and began pacing up and down the aisle, holding a newspaper he had purchased before boarding. When someone asked him what was wrong, a friend's voice piped up "He's looking for a microphone, so he can read his newspaper."

COMMUNICADOS

The news isn't the only thing on Radio Zaracay that North American listeners might find unusual. When Radio Zaracay broadcasts local announcements, they may seem far more personal than any broadcast on radio stations in the US and Canada. But in Ecuador, and elsewhere in Latin America, local announcements, usually called comunicados or anuncios de servicio social, take on a somewhat different role. They sound personal, because that's exactly what they are meant to be.

Comunicados are the personal classifieds of the airwaves of Latin

America. In most countries of Latin America, many smaller and villages and towns have no phone service. Even in towns with telephones, many people don't have them because either they can't afford one, or there is a long waiting list and their name hasn't come up yet. So radio stations fill the gap with comunicados.

A comunicado is a personal announcement broadcast over a station. The person who wants to send the message pays to have it read over the air. It's a small fee, usually less than fifty cents. The message can be anything.

Comunicados are the personal classifieds of the airwaves of Latin America.

Perhaps Mom wants to take the kids and visit Aunt Elena in a nearby village this weekend. She doesn't want to surprise the dear old lady, so she sends little Antonio over to the local station with some money and the comunicado message written on a piece of paper. Even if Aunt Elena doesn't hear it, one of her neighbors surely will. Maybe Don Fernando wants to send a message to the workers on his plantation, but doesn't have the time to drive out today. He just drives over to Radio Zaracay to have them do a comunicado. Most stations read comunicados at specific times of day, usually over the meal hours. Everybody wants to listen to the comunicados. Even if they aren't expecting one for themselves; it's like a partyline with all sorts of possibilities for juicy gossip.

Comunicados go out several times a day at Radio Zaracay. Don Holger likes to host the mid-afternoon airing. Reading comunicados helps him keep up with events in the community - and also gives him some interesting stories to tell. You never know what people are going to come with.

For example, there was the time a man came in with a an urgent comunicado for his mother in

Esmeraldas, 100 miles away. The message? It was "Mother, will you please come to Santo Domingo tomorrow. I am getting married. Much love, your son Rigoberto." Then there was the comunicado heard on Radio Zaracay from a Jacinto Delgado to his wife, asking her to send another hen, as the last one flew out the car window! Another time, a listener dropped off an obituary to be read, which listed the names of all the survivors, but forgot to mention who died.

One of Don Holger's favorite stories is how once a pair of young lovers came to him and asked if, according to local custom, he would be the patron (godfather) of their marriage. He agreed on the condition that the marriage had been approved by their parents. They said it was, and gave him three hens as a gift, and Don Holger saw to it that the impending wedding was announced on the air. Later that day, the father of the girl sent a message to the Don Holger, saying that he was opposed to the union. A few days later, the no-longer-happy couple stopped by and asked for the hens back.

RAGS-TO-RICHES

The story of Radio Zaracay is the rags-to-riches story of owner and founder Holger Velastegui. He was born in the village of Quisapincha in Tungurahua province on December 30, 1934, the eldest son of his family. As a teenager, he walked thirteen kilometers each way between home and high school in nearby Ambato. Graduating from high school in 1953, he moved to Guayaquil, where he worked his way through college as an announcer for Radio Ortiz, and later for Radio Cent. In 1957, he moved to Quito to continue his studies, meanwhile earning a living by working for Radio Central, Radio Nacional Espejo, and Radio Reloj.

In 1959, Don Holger finished his studies. One of his former employers, Señor Luis Rivera, manager of Radio Central, was considering expanding his operations into a provincial town that at the time had no radio station of its own. Rivera offered to help Don Holger set up a station in Santo Domingo de los Colorados.

With six years experience, Don Holger certainly was no novice at radio broadcasting. Still, this was going to be, at least in part, his own station. He wanted it to be as professional as possible. In the 1950s, the most modern and professionally run radio stations in the region were in Colombia. Don Holger wanted to see first hand how one of these Colombian stations operated. An agreement was made so that Don Holger would travel to Colombia while Señor Rivera took charge of equipping the new radio station.

In Cali, Don Holger found temporary work at one of Colombia's premier stations, La Voz del Rio Cauca. He spent two months learning everything he could at La Voz del Rio Cauca, and visiting other nearby stations, always looking for someone who would answer his questions on program production, studio operations, and managing a radio station.

When he returned to Ecuador, the equipment wasn't ready yet. There wasn't much Don Holger could do in the meantime, so he decided to get to know his own country. For the next two months, he traveled across Ecuador, visiting towns, villages, and rural farms. He talked to the people & asked them what they liked to hear on the radio. He found that the average Ecuadorian preferred his own folk music to any other type of music. Everyone liked to listen to the news, but people preferred news that reflected positively on mankind. Sports was very popular, and there was actually a demand for broadcasting volleyball games on the radio. Everything Don Holger learned helped him form his own philosophy of what radio programming should be like.

When Don Holger returned to Quito, though, disaster struck; Señor Rivera backed out of the project. Without someone to bankroll the new station, Don Holger could never get in on the air by himself. But, the people of Santo Domingo wanted their own radio station. Maybe new support could be drummed up there. After several weeks of talking to leading citizens of Santo Domingo, several agreed to lend Don Holger money for the new station. Modesto Jarrin, owner of La Voz de los Lagos in Otavalo, agreed to rent them

his twelve watt backup transmitter. Santo Domingo had no electricity in those days, but a local family agreed to rent them a generator to power the station. However small and makeshift, Santo Domingo, and Don Holger, would get a radio station.

FINALLY ON THE AIR

Called Ecos del Occidente, the new station finally made it on the air on August 29, 1959, and a month later, on September 29, it was officially inaugurated. Initially, the station only broadcast from six to ten pm daily, on 3485 khz. But the townspeople were proud; Santo Domingo finally had its own station. Perhaps local pride in the station helped make it a success. Just seven months later, in March, 1960, Don Holger bought the station a new five hundred watt transmitter from the Rosenkranz shop in Ibarra. In those days, transmitters were known by who made them. This one was designed and built by Señor Segundo Obando.

With the raise in power, Don Holger decided to change the station name to something that truly reflected the region around Santo Domingo. Radio Zaracay was chosen, in honor of Joaquin Zaracay, who until his death in 1942 was tribal governor of the local Colorado Indians. He was still admired and loved by the people of Santo Domingo. The new transmitter changed a few other things too. For the first time, the station became officially licensed. Also, the first of thousands of overseas reception reports began to filter in.

Not long afterwards, another important change happened at the Radio Zaracay; Santo Domingo was hooked up to the Quito area power grid and began to receive electrical service from 6-8 A.M. and 6 P.M. to midnight every evening. The generator was no longer needed, and transmission time could be increased.

In the 1960s, technical advancements came regularly. In 1962, medium wave was added on 965 khz, using a 250 Telco watt transmitter. In 1965 a new Telco transmitter was purchased to increase the power on shortwave to one kilowatt. In 1966, the station was able to extend programming

all day long when the power company began providing Santo Domingo electricy 24 hours a day. Of course, technical advancements at the station were only possible because of popular programing, which brought in advertisement revenue. Don Holger's philosphy of radio programming was paying off. In fact, Radio Zaracay had become so popular that a Japanese company contracted the name Zaracay for a brand name of radios to be marketed in Ecuador and southern Colombia. Zaracay radios are still sold there today.

In 1968 the shortwave frequency had to be changed to one in the sixty meterband when 3485 khz became part of a band reserved for emergency aeronautical use. However a mistake had been made in Quito, and Zaracay assigned the same frequency as La Voz de

Esmeraldas, just 100 miles away. After a month of mutual interference, and numerous phonecalls to Quito, Radio Zaracay was reassigned to its present 3395 khz frequency. Apparently there were no hard feelings between the stations, as in 1970 La Voz de Esmeraldas' engineer, Al Horvath, built a new five kilowatt shortwave transmitter for Radio Zaracay.

On September 12, 1972, Radio Zaracay moved into its new, present, location, the six story "Coliseo Zaracay" building. The station continued to prosper in 1976 when a ten kilowatt CONTEL transmitter from the US was purchased for 3395 khz. It was installed at a new transmitter site five kilometers outside Santo Domingo. This gave the station truly national coverage. In 1981, a 12.5 kilowatt Ecuatronic transmitter was added for 965 khz. This was a modulated pulse transmitter, which supposedly gave FM quality on MW.

HEMISPHERE'S HIGHEST ANTENNA?

By the late 1970s, FM was the future of serious radio broadcasting in Latin America. Urban audiences were beginning to expect more quality than AM or SW could give. So, in 1979, Don Holger applied to a government for an FM license, under the name Estereo Zaracay. His application was turned down, because it involved putting the antenna on Bomboli Hill, just outside Santo Domingo. IETEL (the Ecuadorian telephone company) and the Ecuadorian armed forces already had installations on Bomboli Hill, and it was feared Estereo Zaracay would cause interference to them.

Undaunted, Don Holger decided to think even bigger. He reapplied with plans to put the FM transmitter site on the side of Mount El Atacazo, where it would be in line of site of Santo Domingo, Quito, and much of the northern half of the country. This time his application was approved.

However, there were already several other companies using the mountain, including IETEL, Texoco, and two television stations.

These companies had a monopoly, which made them owners of all electrical service on the mountain. An agreement was worked out where Estereo Zaracay would be provided with electricity, only if the antennas were constructed several kilometers from the other installations, and at a much higher altitude. That would be no easy task.

The Ecuatronic company was commissioned to study the possibilities. They chose a remote site on top of the mountain, at 4200 meters above sea level. Don Holger hired a Mexican oil company, with experience in building roads in rugged conditions, to build a road to the site. The equipment was instatted at 4,200 meters above sea level. Señor Velastegui says this makes Estereo Zaracay the highest radio station above sea level in the Western hemisphere. The new FM station was officially inaugurated on June 12, 1981. The



transmitter on Mount El Atacazo is a 12.5 kw one, built by Ecuatronix. Additionally, ten repeater stations have been strategically placed on various mountains to receive the signal from Atacazo and relay it further. As a result, Estereo Zaracay covers all of Northern and Central Ecuador, and even a portion of Southern Colombia.

ANTENNA SITE

The station visit was over, Don Holger offered to take Theresa and I on a tour of the area. I headed back to our room, and about 30 minutes later Don Holger came by in his jeep. First he drove us out of town for a first hand look at the Colorado Indians. One of Don Holger's best friends was a Colorado witch doctor. We soon arrived at the witch doctor's spacious clean thatch house which was surrounded by lush vegetation and flowering vines. It was a sort of Eden-like paradise. The biggest surprise, however, was the witch doctor - he and his wife are the two Colorados on the HCJB QSL card! For about an hour he explained his people's medicinal uses of the various plants around his house, as well as the incantations necessary to make them work. As we drove away, Don Holger confided that while he really found it hard to believe in much of what we had heard, he had seen a lot of it work.

After visiting the witch doctor we visited a few less climatic local attractions and stopped for some fresh picked pineapple. One of the many interesting things we learned while driving around was that Santo Domingo is a sister city with Bowling Green, Kentucky. On various occasions, officials and prominent citizens of Bowling Green had visited Santo Domingo, and those from Santo Domingo, including Don Holger, had visited Bowling Green. Don Holger, in fact, had been there on several occasions and one of his four sons was going to school at Western Kentucky Universtiy in Bowling Green. The others would go when they finished high school.

Lastly, we stopped by Radio Zaracay's brand new transmitter site. Radio Zaracay's AM and SW transmitters had just been moved to this

new site, several miles outside the city. Part of the reason for the move was to put up a new SW antenna, directional towards the Galapagos Islands. Although Estereo Zaracay already had an FM repeater there, Don Holger wanted to be sure the inhabitants of the Galpagos had no problem hearing both of the Zaracay stations. Radio Zaracay on shortwave was the most popular mainland station in the islands. Many Ecuadorian families who had relatives on the Galapagos, used Radio Zaracay whenever they needed to send a comunicado.

In place of remote control at the transmitter site, Don Holger employed an elderly man as a caretaker. His primary job was to turn the transmitters on and off. The old man had his own little apartment, furnished by Don Holger, in the transmitter building. The old man pointed out that he had a refrigerator, TV, and fan, so he lacked nothing except company. Few people come out to the transmitter site to visit him. He spent most of his time either watching TV or taking care of the corn he had planted under the antennas.

Our visit was over, and it was late when we got back to town. Don Holger dropped us off by our pension, and we waved good-bye. Early the next morning we were on another bus on our way to another town and another station. Because of Don Holger's immense hospitality, the visit to Radio Zaracay has also remained one of the most memorable of my station visits. In the years since, I would frequently tune them in on 3395 kHz and remember Don Holger sitting at the microphone, reading comunicados, or the old man at the transmitter site growing corn under the antennas. Radio Zaracay may be gone now, its future in FM Estereo Zaracay, Ecuador's most popular station. But regardless of who is on the frequency, to me, 3395 kHz is always going to remind me of Radio Zaracay and Don Holger Velastequi, the man who set out to make the best radio station in Ecuador and succeeded.

African Destinations

Bill Kurrasch
5607 Lincoln Road
Ontario, New York 14519
GENIE W.KURRASCH

You will remember that in our last African Destinations we highlighted the country of Liberia. Up until that time that nation was one of the hot spots on the continent. Things haven't cooled off there very much, but now with Somalia in the forefront, the media has altered its focus. This months column will provide some background information on the troubled nation of Somalia.

Somalia, or sometimes referred to as the Somali Democratic Republic, is a republic of East Africa. It is bounded on the north by the Gulf of Aden, on the east and south by the Indian Ocean, on the southwest by Kenya, on the west by Ethiopia and on the northwest by Djibouti. The total land area encompasses 246,201 sq.mi.

Land and Resources: Somalia has a very long coastline, extending for approx. 1700 miles. Unfortunately it has only a few natural harbors. A sandy coastal plain borders on the Gulf of Aden in the north. A series of mountain ranges with average elevations between 3000 and 7000 feet is prevalent in the northern portion of the country. To the south, the interior consists of a rugged plateau. Also in the south along the Indian Ocean exists a wide coastal plain which consists of many sand dunes. The country's two major rivers are found on the southern plateau, namely the Juba in the south and the Webi Shabelle in the south central section.

Climate: The climate of Somalia ranges from tropical to subtropical and from arid to semiarid. Temperature averages around 82°F but it does occasionally drop as low as 32° in the mountain areas and as high as 116° along the coast. The seasons are ruled by the monsoon winds which bring a dry season from September to December and a rainy season from March to May. The average rainfall is only about 11 inches annually.

Natural Resources: Somalia has few natural resources. The grasslands are suitable for grazing livestock and the fertile land along the river valleys of the Juba and Webi Shabelle and in some coastal areas is used for agricultural crops. Mineral resources are quite diverse but have not been widely developed. Known deposits include copper, petroleum, gypsum, iron ore, manganese, marble, meerschaum, tin ore and uranium.

Population: The majority of the population consists of Somali, a Cushitic people. A minority of Bantu speaking people live in the southern part of the country. Other minority groups include Arabs, Indians, Italians and Pakistanis. The majority of the people are nomadic or seminomadic pastoralists. The rest are either crop farmers or inhabitants of the few urban centers.

The population of Somalia is approximately five million. The overall population density is approximately 20 persons per sq. mi. The principal cities are Mogadisho, the capital, with a population of about 390,000 and Hargeysa, with about 75,000 inhabitants.

Religion and Language: Islam is the state religion in Somalia, and most of the people are Sunni Muslims. The official languages are Somali and Arabic. English and Italian are also used.

Education: Education is provided free but is not compulsory. The literacy rate increased from about 5% in the early 1970s to about 75% in the early 1980s following an intensive government-sponsored literacy campaign. The principle institution of higher learning is the Somali National Institution in Mogadisho, with a student body of about 3700.

Economy: The economy of Somalia is based on livestock raising. Crop farming is of importance only in the south. Droughts in recent years have seriously hampered efforts in these areas. Efforts to diversify and modernize the economy are directed by the government through a series of development plans, extensively assisted by foreign grants and loans. In the early 1980s annual budget figures showed revenues of \$307 million and expenditures of \$394 million.

Manufacturing: Manufacturing in Somalia is in the early stages of development. A cement factory, a cotton mill, a meat and fish cannery and a textile plant have been established in recent years. Other industries include oilseed and fruit processing plants, leather and shoe factories and petroleum and sugar refineries.

Currency and Banking: The unit of currency is the Somali shilling which is used by the Central Bank of Somalia. Other banking institutions include the Commercial and Savings Bank of Somalia, Somali Development Bank and branches of foreign banks.

Foreign Trade: In the early 1980's, exports totaled approximately \$141 million annually and imports about \$275 million annually. The chief exports are livestock and bananas. Other exports include meat, fish, leather and hides, and wood. The principle imports are chemicals, machinery, foodstuffs, textiles and petroleum. The country's principle trading partners are Saudi Arabia, Italy, Great Britain, and Germany.

Transportation and Communications: Somalia has no railroads. It does have almost 12,000 miles of roads but only about 6% of which are paved. Mogadisho is the leading port. A government-owned airline and several foreign airlines provide international service.

Several radio stations operate in Somalia. Try for Radio Mogadishu on 7200 and 9475 kHz. English has been reported at 1830 hrs UTC. An opposing broadcaster is occasionally heard broadcasting on 6968 kHz. Reception of these transmissions have not been widely reported in North America. WRTH reports that another station, Radio Hargeisa, transmits on a frequency of 7120 kHz at 1000 to 1230 hrs UTC and 1500 to 1700 hrs UTC using a 1 kW mobile transmitter. I would imagine that reception from this station would indeed be extremely rare in North America.

History: The history of the region, now included in Somalia dates from antiquity, when the land was known to the ancient Egyptians as Punt. From the 2nd to the 7th century A.D., parts of the area belonged to the Ethiopian kingdom of Aksum. Arab tribes in the 7th century settled along the coast of the Gulf of Aden and established the sultanate of Adel, which centered on the port of Zeila. The Somali people began to slowly migrate into this region from Yemen in the 13th century. The sultanate disintegrated during the 16th century into small independent states, many of which were ruled by Somali chiefs. Zeila became a dependency of Yemen, which was then a part of the Ottoman Empire. The first European power in the region was Great Britain. In order to protect the British trade routes and provide safe anchorage for ships, Great Britain took possession of Aden (now in the People's Democratic Republic of Yemen) on the Arabian coast in 1875. Egypt, disregarding Turkish claims, occupied some of the towns on the Somali coast and parts of the adjacent interior. When the Egyptian troops left the area in 1882 to stem the revolt of the Madhi in the Sudan, Great Britain occupied the territory in order to safeguard the route to India through the Suez Canal which was opened in 1869. In 1887 a British protectorate, known as British Somaliland, was proclaimed. Initially under the dependency of Aden, was placed under the administration of the British foreign office in 1898 and under the colonial office in 1905.

Italian interest in the Somali coast developed in the late 19th century. By treaties with the Somali sultans and conventions with Great Britain, Ethiopia, and Zanzibar, Italy acquired a foothold along the coast of the Indian Ocean. British control of the interior was challenged by native revolts between 1899 and 1910. In 1910 the British abandoned the interior and withdrew to the coastal regions. They finally subdued the rebels in 1920. During this period Italy extended control over the area inland from the Indian Ocean. In 1936 Italy merged Italian Somaliland, Eritrea and the newly conquered Ethiopia into the colonial state of

Italian East Africa. After the Italian entrance into World War II in 1940, Italian troops invaded British Somaliland and succeeded in expelling the British. Britain reconquered its protectorate in 1941.

By the terms of the Italian peace treaty adopted in 1947, Italy was forced to renounce title to the possessions in Africa and responsibility for the disposition of these colonies was allocated to the "Big Four" (U.S., Britain, France, USSR). In 1948 the Big Four, having failed to reach an agreement on the disposition, referred the matter to the General Assembly of the UN. A plan granting independence to Italian Somaliland after ten years as a UN trust territory under Italian administration was approved by the General Assembly in 1949. On April 1, 1950, after Italy accepted the terms of the UN trusteeship agreement, the British military government was replaced by a provisional Italian administration. The territory was designated Somalia.

Independence: On July 1, 1960 by agreement with the UN Trusteeship Council, Somalia was granted independence. It then merged with the former British protectorate which Britain had granted independence to on June 26. The first president, Aden Abdullah Osman Daar, elected in 1960, was defeated for reelection in 1967 by former premier Abdi Rashid Ali Shirmarke. On Oct. 15, 1969 Shirmarke was assassinated and within days a military group, led by Maj. Gen. Muhammad Siad Barre, seized power. Barre declared Somalia a socialist state, and in the following years most of the modern economy was nationalized. A drought in 1974 & 75 caused widespread starvation. In mid 1977 ethnic Somalis in the adjacent Ogaden region of Ethiopia initiated open warfare aimed at ending Ethiopian control of the area. The rebels were armed by Somalia, which also contributed troops to the effort. The Somalis captured most of the Ogaden by late 1977, but Ethiopia, with the help of Cuba and the USSR, reasserted control over the region by early 1978, as Somalia's army suffered heavy losses. Subsequent guerrilla fighting in Ogaden and the bombing of villages in the region by Ethiopian planes precipitated a flood of refugees into Somalia. The number of homeless swelled to over two million and many were near starvation. The U.S. gave both humanitarian and military aid and in return was granted use of the naval facilities at Berbera, previously a Soviet base. Hostilities with Ethiopia erupted again in mid 1982.

Severe drought and starvation along with an unstable political climate has led to the current problems and US / UN involvement in Somalia on a humanitarian aid level.

Back in June!

Listener's Library

T. J. "Skip" Arey WB2GHA
P.O. Box 644
Waterford Works, NJ 08089
Genie T. AREY1

We all listen to shortwave frequencies for different reasons. For years the hobby appeared as if it was divided into two camps. DXers, folks who lived for the hunt of unlogged countries and stations, and SWL's, folks who tried to experience the world through shortwave programming. I don't think the delineation was ever really that clear. Most shortwave users are part DXer and part SWL.

The pressing issue for anyone in the hobby, DXer, SWL or both, is what to listen to, where to hear it, and when to turn the radio on. Stations change frequencies, and programming rapidly. Heck, in recent years the countries have been changing almost as fast. Keeping track of all those signals is a Herculean effort. Several folks have made it their career to do this very thing. The Shortwave frequency guide has become a very competitive business in recent years. For this reason I thought we should take a look at the current crop of books available to the hobbyist. Just like there are few pure DXers and solely dedicated SWL's, each of these texts have something to offer everyone. This will be, perhaps, my most challenging column as a "book critic" since I know and respect the editor's of all three publications. I know some of the more experienced readers will want to squawk about devoting this column to such basic texts. If you have been paying attention to the growing list of new members in Bob Brown's NASWA NOTES, you can see that many newer folks need this information.

WORLD RADIO TV HANDBOOK

1993 EDITION

Editor: Andrew G. Sennitt

608 Pages

\$19.95

Billboard Books

ISBN: 0-8239-5924-3

For many years the WRTVH was the single best source of information for shortwave hobbyists. Its comprehensive data on countries, station addresses, transmitter information and program listings make it essential reading for hard-core DXers. The Handbook contains far more information than most radio hobbyists will ever need. Still, I think it's really neat to be able to look up KYRGYZ RADIO's Telex number.

Speaking of Kyrgyzstan, since the Berlin Wall fell, updating a book of shortwave frequencies has become fairly intense. Given that the WRTVH provides so much additional information it is no surprise that the 1993 edition appeared at my doorstep a few weeks later than usual. The hard data section of this book is divided into regions and then into countries. Each country listing gives the local time (+ or - UTC), and demographic information including primary languages. Also listed are the names of key administrative personnel as well as current addresses, phone numbers, fax and telex lines. (Hey, has anyone tried to FAX their reception reports?)

Stations are by frequency and transmitter power level. Details of operating hours and programming languages are also included.

Since confirmation is so important to DXers, verification policy and information are included in each station listing. Station policy coupled with addresses and staff information make the WRTVH invaluable when seeking QSLs.

If you are really digging for those hard to catch signals, you will benefit from the data on transmitter locations, antenna beam headings and target coverage areas. Another helpful feature is a listing of Shortwave Stations of the World by frequency. This will help the listener narrow down the possibilities when monitoring an unknown signal. Also included is a listing of International broadcasts in English by time. This listing will look familiar to NASWA readers because it is compiled in cooperation with The BBC Monitoring Service and our own ENGLISH SCHEDULES Tom Sundstrom's TRS Consultants.

Beyond the station data, the WRTVH provides the hobbyist with other useful information including a complete list of DX and Media programs, Standard Frequency and Time signal Stations, Broadcasting and Religious Organization lists. A good list of world wide radio hobby clubs is also included. Also each edition is filled out with the Listen to The World section, a collection of articles of interest to radio hobbyists including equipment reviews. The WRTVH has never been exclusively for shortwave hobbyists. Medium wave listeners and people with interests in international television and world satellite broadcasts will find important, supportive data.

Editor: Lawrence Magne
416 Pages
\$16.95
International Broadcasting Services, Ltd.
ISBN: 0-914941-40-2

The New York Times calls Passport the "TV Guide for world band radios." As far as this is possible, Passport certainly fills the bill. Given the regular changes that occur throughout the shortwave world, Passport remains my preferred text for just trying to find out what might be interesting to hear when I'm not trying to dig out the internal service of Radio Freedomia. If you don't feel like wasting your brain cells in front of the television you can take advantage of the hourly programming suggestions listed in the "What's On Tonight?" section. You can also fall in love with the picture of BBC's Katty Kay on the page that precedes this section but that is another story.

Passport presents a great deal of information about stations, frequencies and programming in a format that is far less threatening to the beginner than the WRTVH. Passport goes out of its way to make the novice listener at home with the quirks of shortwave broadcasting that more experienced hobbyists take for granted. This book also introduces the newcomer to the verification process. Station addresses and QSL information are included in a separate section called Addresses Plus.

Passport's Blue Pages harken back to Larry's earlier publication Radio Database International. They give a graphical presentation of what can be heard throughout the shortwave broadcast spectrum. The format of this section takes a little getting used to but it remains one of the fastest systems for tracking activity by frequency and time as opposed to consulting separate listings. A complete listing of Worldwide Broadcasts in English (listed by country) is also included. Another section entitled Voices From Home lists for folks with ties to lands beyond the US of A.

Frequency and programming data are only about half the picture. Magne has long been known for his MAGNE TESTS column in Monitoring Times magazine and his RDI WHITE PAPERS. These are comprehensive laboratory analysis of the dominant shortwave receivers in the hobby. Passport includes Larry's investigation of the current crop of portable and desktop receivers. Anyone planning to purchase a new receiver without glancing at Passport's recommendations could be in for financial losses well in excess of Passport's cover price. This 1993 edition also includes an article on getting started in RTTY monitoring by Fred Osterman and an extensive study of world time clocks by Jock Elliot.

Editor: Kannon Shanmugam
176 Pages
\$15.95
Grove Enterprises, Inc.
ISBN: 0-944543-06-5

Kannon Shanmugam is the program manager of Monitoring Times magazine's SHORTWAVE GUIDE. Over the years, Kannon discovered that many shortwave listeners were most interested in programming. Developing a program based guide is no easy task. Thousands of programs air each week. Putting this information into an easy to understand format requires some original thinking.

Kannon accomplishes this task by way of three lists. The first list includes all the major broadcasters and their regular operating frequencies. This list is used together with two program lists, one for October through March and the other covering April through September. This is to account for routine changes in programming caused by summer and winter time adjustments. The program lists let you find out when your favorite programs are on by time and day of the week. You do need to flip back and forth between the frequency and program listings but there really is no better way to get access to over 20,000 program listings from 100 or so different stations. The first ten pages of the book guide you through the most efficient use of the rest of the text.

The 1993 edition shows real improvement over the 1992 edition including a separate listing of programs of interest to radio hobbyists. Unlike the above mentioned books, this text does not include receiver reviews or hobby related articles.

THE BOTTOM LINE

You really can't choose any one of these texts over the other. They are all shortwave frequency guides, but each has its own appeal. Hard-core DXers out to hear and verify every station on the bands will gravitate toward the data intensive World Radio TV Handbook. Most general interest listeners and beginners will get the most bang for their buck out of Passport to World Band Radio. Listeners who only want to find out when their favorite programs are on will lean toward the Guide to Shortwave Programs. Your own listening habits will dictate which book will serve you needs.

SPECIAL NOTE

Longtime radio hobby writer EDWARD M. NOLL's book EASY UP ANTENNAS FOR RADIO LISTENERS AND HAMS is once again available from MFJ Enterprises, Inc. PO Box 494, Mississippi, MS 39762 at \$9.95 plus shipping. I will be reviewing this and other Ed Noll classics in next month's column.

REDUCING FADING

Fading is the most important cause of distortion that detracts from the enjoyment of program material transmitted on shortwave. Fading occurs on strong signals and weak signals. Increasing the transmitter power does little to improve the distortion caused by fading. An analysis of the different causes of fading is presented this month along with some ideas on measures broadcasters and listeners can take to reduce the effects of fading.

What causes fading ?

There are two primary causes of signal fading on shortwave, multipath cancellation and polarization rotation. Each type of fading results from different mechanisms and each has its own remedies. These effects can be minimized by appropriate design of transmitting antennas, receiving antennas, receiving techniques, and redundancy in the receiver configuration.

Multipath propagation results in the signal being received by the listener over two or more paths. A typical circuit is shown in Figure 1. One path consists of a single, low-angle hop from the transmitter to the receiver. The other path consists of two hops at a higher angle. The two-hop path is physically longer than the single hop path. When the two waves combine at the receiver, they can be in phase. In this case the waves act to reinforce one another making the received

signal stronger. Because the delay difference is a function of the path length difference, the waves can just as easily arrive out of phase causing cancellation or what we normally call fading.

Wavelength is inversely proportional to frequency. The bandwidth of an AM transmission is normally about 10KHz. Sidebands extend above and below the carrier frequency by 5KHz or more. Waves arriving via multiple paths can cancel at one frequency but not at another. This effect gives rise to what is called "selective fading". Selective fading can result in the carrier fading while the sidebands remain strong. The result is severe distortion similar to overmodulation. Selective fading can also result in one sideband fading while the other remains strong. Distortion also results from this condition.

The polarization of the signal after it passes through the ionosphere is rotated by a phenomenon known as "Faraday Rotation". Normally, the signal transmitted by the broadcaster is horizontally polarized. (WWV is an exception to the rule; they use vertical polarization.) This means that the electric field is parallel to the surface of the Earth. When the wave transits the ionosphere, the presence of free charged electrons and the Earth's magnetic field combine to cause the electric field vector to

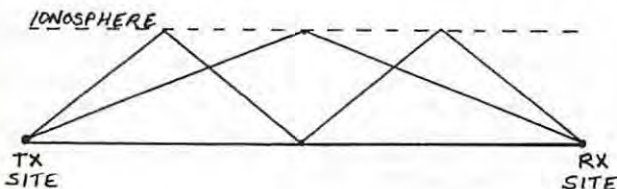

Figure 1. Multipath propagation causes fading when waves arrive out of phase.

rotate. Thus, the wave returns to Earth with the electric field oriented randomly. When the receive antenna wire is aligned parallel to the electric field vector, maximum energy is captured from the passing wave. When the wire is oriented perpendicular to the electric field vector, no energy transfer occurs. As the orientation of the electric field vector shifts, the signal fades up and down. The amount of rotation of the electric field vector at any instant is a function of frequency so selective fading can occur at different frequencies within the signal bandwidth.

How can the situation be improved ?

International broadcasters already attempt to minimize multipath propagation by concentrating radiated energy at the horizon. Curtain antenna arrays and rhombic antenna designs used by the big guns attempt to minimize high angle minor lobes to reduce the amount of energy reaching the receiver via more than one path.

FM broadcasters have found that automobile reception fading is reduced by transmitting circularly polarized waves. Circular polarization can be thought of as simply horizontal and vertical radiation with a 90 phase shift between the two polarizations. Although such transmissions would seem to be beneficial in reducing polarization-induced fading on HF paths, no international broadcasters are known to be using this technique.

The effects of selective fading can be minimized by the use of single sideband (SSB) and synchronous detectors. Single sideband reception of a double-sideband, AM signal allows the operator to select either the sidebands above the carrier frequency (USB) or below the carrier frequency (LSB). Ignoring the other sideband allows that sideband to fade without contributing to distortion. The SSB receiver also reconstructs the carrier. Selective fading of the carrier does not contribute to SSB distortion because the carrier is filtered out before the detector.

High fidelity reception of SW signals using the SSB technique is not possible for two reasons: 1. The frequency of the reconstructed carrier is not exactly the same as the frequency of the transmitted carrier; 2. The frequency of the signal as received will wander due to path length variations which result in Doppler shift. Listen on 5MHz some night when YVTO and WWV are both competing. Beats of three or four Hz are clearly evident even though the frequencies of both stations are controlled to better than one-thousandth of a Hz by atomic standards. The

Doppler shift varies erratically with time in an unpredictable manner. Three or four Hz error does not bother voice intelligibility but would be noticeable to a good ear on music.

Doppler shift can be eliminated by allowing the reconstructed carrier to track the incoming signal. This is where the synchronous detector shines. Signals demodulated by a sync detector are not subject to selective fading of the carrier as long as there is enough carrier present to keep the detector locked. Long time constants on the carrier-tracking, phase-locked loop allow the synchronous detector to "fly-wheel" through short carrier fades without losing lock.

These distortion-causing effects can also be reduced by the use of diversity reception. Harold Beverage of Beverage antenna fame died on January 27, 1993 at the age of 99. He had over 90 patents to his credit but the two he was most proud of were the wave antenna, as he called it originally, and diversity reception. There are three types of diversity reception techniques which the SWL can use to minimize fading and distortion:

1. Frequency diversity;
2. Spatial diversity; and
3. Polarization diversity.

In all three cases the same information is received via redundant paths and combined at the receiver site into a high quality signal.

Define what is meant by frequency diversity.

In frequency diversity reception the same program material is received simultaneously on two or more frequencies. If the frequencies are separated by more than 100KHz, the paths will likely fade at different times. Let's say the BBC can be heard on 12.095 and 15.070 MHz. You will need one receiver on each frequency. Combine the outputs and you have frequency diversity reception. One caution must be observed. The transmissions should originate from the same site. Relay stations are typically fed by satellite circuits. Each satellite hop to geosynchronous altitude results in a round trip time delay of 1/4 second. An annoying echo effect is all that will be heard if the two frequencies do not originate at the same site.

How are the signals combined ?

There are two general methods, pre-detection and post-detection, for combining diversity signals. Pre-detection combining can have some

signal-to-noise ratio advantages but requires complex circuits and phase-stable paths. Because ionosphere-reflected signals continuously shift in phase as the path length changes, post-detection combining is the most practical technique for the SWL. One approach could use the AGC voltage from each of two identical receivers to control the switching logic. The logic would select the stronger signal at any instant.

A simpler approach would be to feed each receiver into the separate inputs of a stereo audio system. The combining is then done in the listener's brain. As fading occurs the aural image of the sound will appear to wander between the two stereo speakers.

This wandering effect might at first be annoying but with a little "getting used to" will provide a dynamic demonstration of the variability of ionospheric paths. If the listener finds this effect annoying, the stereo amplifier can be configured for monaural operation. In any case the gain of each receiver should be limited by use of the RF gain control to avoid noisy, distorted audio during fades.

Such a system is depicted in block diagram form in Figure 2.

How does spatial diversity work ?

Spatial diversity is based on the fact that if the signal is received on two antennas separated from each other by more than a wavelength or

so, the fades will not be correlated. Fades on one antenna will not be accompanied by simultaneous fades on the other antenna. In this case both receivers shown in Figure 2 could be tuned to the same frequency.

Another form of spatial diversity can be obtained with a single receiver by simply using a long-wire antenna of more than one wavelength. The theory here is that the large physical size of the antenna means that somewhere on the wire the multipath waves are not cancelling so there will always be an output. Long-wire antennas, mounted high and in the clear, will exhibit gain and directivity at low elevation angles. Because high angle multipath signals are discriminated against by such an antenna, fading effects are reduced compared to a half-wave dipole or smaller antenna.

What is polarization diversity?

Polarization diversity allows the receiving system to extract energy from the wave regardless of the orientation of the electric field vector. One approach to polarization diversity is to orient the two antennas in Figure 2 so that one antenna responds to horizontal fields and the other responds to vertical fields.

A future column will cover a circularly polarized antenna design that allows polarization diversity reception using a single feedline and receiver. Until then, stay tuned.

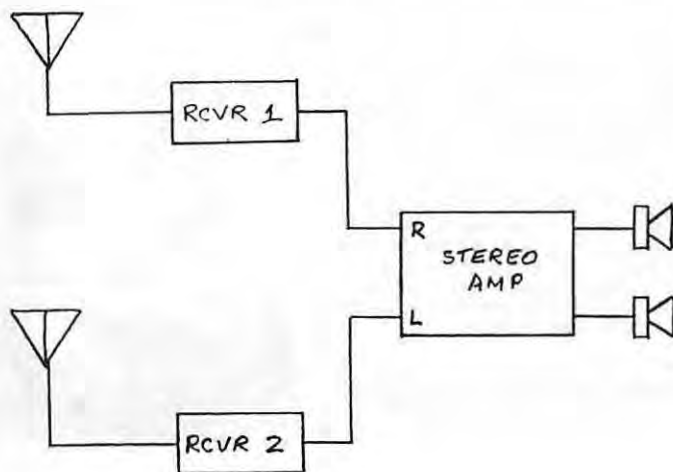

Figure 2. Two receivers, two antennas and a stereo amplifier makes a poor-mans diversity receiver.

NASWA Portraits

Jerry Klinck
43 Lein Road
West Seneca, NY 14224



Welcome to another Portrait. Just a reminder, this column needs a steady flow of input to survive. I have just two profiles left here, so now is the time to send in your story. I see a nice number of new members each month. How about introducing yourselves to the rest of us?? Now off to Carmel, CA on a visit with NASWAN Ron Howard who will tell us about HIS "Happy Days" of DX...

"Here I am, finally of age. Yes, 21 years of being educated, at times thrilled and mostly just simply entertained by being a DXer, a QSLer and a member of NASWA. It was 1971 that I got a basic receiver to listen in on what I could catch. In a very short time I saw the need for a better receiver. So I invested in a Heathkit SB-310 and, after some correspondence with an excellent DXer, Jerry Berg, who gave me some technical assistance, I got down to some serious listening. I even went so far as to get a second receiver, an HQ-180A. (good choice - ed.) They both proved to be great receivers. In the beginning, I was very fortunate to have the help of another gifted DXer, Dan Henderson (who lived several towns away from me in Maryland.) With his expert guidance I was able to learn a lot about our hobby and he got me over the initial strangeness of all the abbreviations and taught me the importance of the sunrise and sunset tables. Without his and Jerry's initial encouragement I do not think I would have continued listening these 21 years."

"Living on the east coast I was able to many of the basic African and European stations, and shortly after one year I had my first 100 stations logged and verified. It was fortunate, what with today's higher prices for postage, that I was able to get so many QSLs at a small cost and with so little difficulty. It certainly makes it easier for me today to just concentrate on the few QSLs that I'm interested in now, rather than starting out in our hobby and having to go after everything. But maybe things just seemed to be easier in the past and that, in fact, the novice QSLer today can experience as much pleasure in his or her pursuits as some of us did in the past. I would like to think so."

"When I moved to California, I was able to work more on the Asian and Pacific stations, which are still my favorite areas. In fact it was my biggest thrill to hear WSZO from the Marshall Is-

lands, in their first week of operation. I was just going past 4940 kHz one evening when I heard a station I had not noted before. I took a minute to see if I could get an ID on the hour. At first it sounded like a new Papua New Guinea station, but then there was a clear ID as WSZO - the Marshall Islands. It's not often one can be lucky enough to get a new station in a new country without any prior notice."

"With the passage of time it was necessary to make a change in my radio, so I went to the Icom R-71A which is a set very different from the old SB-310 and the HQ-180A. It has proven to be an excellent receiver and has given me many years of listening pleasure. Never one to be technically minded, I find the set very easy to operate and have never had any problems with it."

"The changes I have noted in NASWA over the years have always been for the good. The editors certainly put in a lot of work, along with Bob Brown and crew. The results of that labor of love are seen month after month in the JOURNAL and can only be described as outstanding! I look forward to another 21 years of being educated, thrilled and entertained by NASWA and, YES, I will endeavor to send in my QSL and reception information as often as possible."

Thanks for the interesting story Ron. I'm sure Vern and Sam would love to hear from you. And thanks to all who have submitted profiles to date. Till next time 73zzzz



the **CPRV** page

COMMITTEE TO PRESERVE RADIO VERIFICATIONS

JERRY BERG, Chairperson • 38 Eastern Ave. • Lexington, MA 02173 • (617) 861-8481

APARTADO 25

"Radio Guanacaste"

APARTADO 25

Organización Comercial para Guanacaste y con Auditorio en toda la Nación

Sirve al País en sus intereses culturales y a la iniciativa particular en sus nuevos centros comerciales

FOLKLORE - VARIEDAD DE PROGRAMAS Y MUSICA AGRADABLE PARA TODOS

LIBERIA, COSTA RICA, C. A. 2000 71,1253



San José, _____ de 193__

Recibi su atenta carta del _____ de _____

Según las especificaciones, que apunta, del programa castado por Ud., de la Estación "ALMA TICA", ellas _____ concuerdan con la transmisión de ese programa radiodifundido por éste, su estación, al mismo día.

Dándole las gracias por su valioso informe y esperando recibir de Ud. nuevos reportes, soy su Atto. y S. S.

Gonzalo Pinto

18A 70888

Cable Cerve 5830 Sx.
Cable Larga 580 Sx.
1000 Watts

Director y Presidente:
Gonzalo Pinto Hernández

APARTADO 800 - SAN JOSE DE COSTA RICA, AMERICA CENTRAL

TIGPH
ALMA TICA

TRANSMISORES: Centrados a
estudio. Tubos finales en ambas
secciones, generador de onda
con un capacitor de 400 m. mho.
con 3300 volts.
RECEPTOR: Superheterodino
FM/DC 1038.

Muy agradecido por su reporte

De Ud. atento servidor.

por ALMA TICA
Luis Cordero Castro
Luis Cordero Castro.



If you think about the early days of Costa Rican shortwave, the first station that will come to mind is TI4NRH in Heredia, which was well chronicled in the May 1990 PopComm. But there have been many other shortwavers in that country, and several of them are shown here. +++ TIMC, Radio Guanacaste in Liberia, Costa Rica broadcast on 6200 kHz. when it issued this QSL letter in 1953. +++ In 1938, TILS called itself Broadcasting Station "Para TI" and transmitted from San Jose on 5900 kHz. SW and 880 MW. +++ And the two QSL's at the bottom are from TIGPH, Station "ALMA TICA," which used to transmit on 5830 kHz. and 650 MW. +++ CPRV is happy to hear from people who have, or know the whereabouts of, QSL's in need of a new home. If you are interested in the future of your own QSL's, check our Registered Collections program operated by John C. Herklimer, P.O. Box 54, Caledonia, NY 14423. We will supply stickers for your QSL albums, reflecting the wish that your veries be donated to CPRV when you are no longer able to enjoy them. Full details are available from John Herklimer (business size SASE, please). +++ *B*

A Committee of the Association of North American Radio Clubs

Listener's Notebook

Dan Ferguson
P.O. Box 2604
Dale City, VA 22193
CompuServe 76702,771

COPYRIGHT NOTICE - Items credited to WBI (World Broadcasting Information) are copyright by the BBC Monitoring Service and may not be reproduced without BBCMS permission.

All times, dates, and days of the week are GMT (UTC), dates are MM/DD or MM/DD/YY.

ALBANIA - R. *Tirana* on new 9633.8 (ex 9724.7) carrying an Albanian program at 2000. (WB DSWCI via HJ)

ALGERIA - R. *Algiers* English schedule is 1800-1900 on 9535, 17745 2100-2200 on 11715. (Cushen in DX'ers Calling via HJ)

AUSTRALIA - *Australian Armed Forces Radio* (AAFR) began broadcasting from 0530-0600 *daily* to Australian forces in Somalia 1/28 via R. Australia's xmtrs at Darwin on 17840 kHz. AAFR welcomes reception reports from anywhere in the world. The QTH is: Lt. Kerry Martin, Australian Armed Forces Radio, B/4/22/N, Russell Offices, Canberra 2600, ACT, Australia. Send a correct reception report, a SASE, and 2 IRC's for a QSL from AAFR. The staff enjoys what they're doing. They are hoping to expand later, perhaps with a service for the Australian troops in Cambodia. (Mike Bird and JM on RNMN 2/4) R. Australia will provide a general English service at 0400-0529 on 17840 from Darwin. Call sign for the AAFR transmission is 2AAFR. (RNMN via WBI 2/5)

R. *Australia* has advised of a new QSL policy: one verification per listener per transmission period (W93 and Z93), or 2 QSLs per year. They are still keen to get reception reports at any time, but cannot verify them. (AC on RNZI 2/4) [Sounds like they have locked the bait in the tackle box. - mf]

At the end of January, one of the six 100 kw Harris xmtrs at Shepparton suffered a component breakdown and a small fire. The staff put out the fire but the xmtr was severely damaged and will be silent for weeks if not months. (Mike Bird on RNMN 2/4)

AZERBAIJAN - *Radio Dada Gorgud* has moved its 1700 xmsn in EE from 6175 to 9840 kHz, relayed via Radio Moscow. The new frequency is blocked in Europe by the Voice of Vietnam. (BBCM/JM on RNMN 2/4)

BANGLADESH - *Radio Bangladesh* sked is: 0000-0415 on 4880; 0415-0900 on 6195; 0900-1150 on 7079 & 6195; 1150-1430 on 15520 (irregular) (from 1230) and 4880; 1430-1600 on 15520 & 4880; 1600-1730 on 15520 kHz. English news is carried at 0130-0140, 0305-0310, 0700-0705, 1255-1300, 1530-1545 and 1705-1710. (WBI 2/12)

BELGIUM - From 1/31 R. *Vlaanderen International* was to transmit a weekly program for Belgian troops in Somalia at 1700-1800 Sundays on 15540 kHz. (WBI 2/5)

BOLIVIA - R. *Metropolitana* is a new station on 6195v. S/on varies 0900-0930 and much of the program is in an Indian language (presumably Quechua and/or Aymara), not Spanish. (WOR via ODXA)

R. *Emisoras Villamontes*, 4599.7, is inactive. (Klemetz Play DX via HJ)

R. *Abaroa* noted active on 4712 kHz iding as "Abaroa e emisora". (HJ)

R. *San Miguel*, 4925.7 kHz, morning newscast goes by the name La Voz de la Selva. (Klemetz DXSF via HJ)

R. *Animas* heard with id at 0240 on 4990.97 kHz. Only heard in our local evening. (HJ)

R. *Metropolitana* is a new station on 6194.5 kHz, relaying its 930 khz AM. IDs as 930 kilociclos R. *Metropolitana* and slogan as *La Radio Popular mas Popular*. Don't confuse with Radio Cuzco, Peru which is also on this frequency. (Barerra NU via HJ) [Heard here in the mornings on top of Cuzco. -HJ]

BOSNIA - Sarajevo is again being heard on 612 MW. (BBCM/JM on RNMN 2/4) //6219.9 kHz. (WBI 2/5)

BOTSWANA - The VOA relay base at Gaborone has been a source of interference problems in Europe and North Africa. These problems did not occur in Liberia before that VOA base was overrun by the civil war. "Coverage into Europe and North America has been as good or better as it is into East Africa"

on occasion. "It seems to provide an amazing path that we didn't realize existed until we had a SW station there. It's more than making up for certain coverages that we had from Liberia. We're missing the number of xmters that we had (10) in Liberia. We have only four in Botswana, so we miss the depth of coverage. But for 100 kw it's doing very well, and we're very happy with it." (Bill Whitacre, VOA, and JM on RNMN 2/18)

BRAZIL - *R. Marajoara*, Belem, 4955 kHz, at 0215 with pop music, ID, time check; poor signal in Quito. *R. Brasil Central*, Goiania, 4985 kHz, at 0803 with music and DJ continuity. (KMH/QLB/DXPL 1/22) [WRTH 93 says 24H. Watch out, Ken's really loose.--mf]

R. Educadora is the station on 3375 kHz here in the mornings at around 1000, not *R. Nacional* although the slogan "Nacional" is being used. (Orr FT via HJ) [Thanks, Tony, I thought I was hearing *R. Nacional* here for a while. HJ]

BULGARIA - A February New Year's card from *Radio Sofia* came with the following information. Radio Sofia is in its 56th year of broadcasting. It transmits in 12 languages (Albanian, Arabic, Bulgarian, English, French, German, Greek, Italian, Portuguese, Serbo-Croatian, Spanish and Turkish) for a total of 45 hours per day. English to North America at 0100-0145

UTC on 7225 kHz, 9700 kHz, and 11720 kHz and from 0400-0530 UTC on 7290 kHz, 9700 kHz and 11720 kHz.

The station held its annual "New Year's Poll" which required an response by February 1, 1993. I guess if you actually listened to this station you had a shot at entering. [D'Angelo]

BURMA - (Clandestine) The *Voice of Democratic Burma* in Burmese, from 1430-1530 via Norway, moved from 15140 to new 15180 at the end of January. It can be found easily because of the distinctive jammer [which seems to wiggle its freq without actually putting any modulation on the carrier--mf]. The jammer is effective to some degree in Sri Lanka but does not greatly affect the readability of the program. The program resembles a domestic radio service rather than a hard-core clandestine operation. (VG on RNMN 2/4)

CANADA - *CKFX*, Vancouver, 6080 kHz, is due back on the air in early March after a year's silence. The original ten watt xmt gave up the ghost in late 1991 or early 1992. It went on the air in the early 1940's [i.e. during World War II] to serve fishing communities on the British Columbia coast. These towns and villages now have CBC repeaters if not local commercial stations. *CKFX* now exists mainly to serve DXers, according to *CKFX/CKWX* chief

engineer Jack Weed. "So the idea is, if it doesn't cost a lot of money, to keep it going." The original xmt was not repairable. Management decided not to fix the old xmt, so *CKFX* bought a used xmt which Weed is modifying for use on 6080 kHz. It should be ready in early March. During sunspot cycle peaks, *CKFX* has received QSL requests from "literally all over the world, including Europe, Oceania, Australia, New Zealand, and certainly many from North America." The original antenna at *CKFX* was a two-quarter-wave vertical array. The current antenna is a single vertical array. (RNMN 2/4)

The C.E. of *CKFX/CKWX* is Jack *Wiebe*, not Jack Weed, according to WRTH 93. (mf)

CHINA - From 1/20 *Fujian PBS* noted with new sked: 2340 kHz at 1030-1700 & 2050-2315. On 5040 from *2315 and to 1030*. Xizang PBS, Lhasa, is no longer active on 5240 kHz, since 1/17. (Toru Yamashita via Tsutomu Kito, Japan)

Honghe PBS Geiju heard on 4929 kHz at 2330. (DP in DSWCI via HJ)

The relay via Russia of *China Radio International* at 2200 is on 7170 kHz, ex 9880. (WB in DSWCI via HJ)

The schedule of *Xinjiang PBS*, Urumchi, is: Chinese *1100-1650* on 2560, 3960 (ex 7385), 4501, 6100. Uighur at *1045-1650* on 3990 (ex 7195), 4735, 5800. (Kito DSWCI via HJ)

Xizang PBS, Lhasa, has Tibetan on new. 4820 *1400-1550* // 4035, 5950, 5995. (Kito DSWCI via HJ)

Yunnan PBS, Kunming, Educational Program is now on 5958 *1045-1229*. (Kito DSWCI via HJ)

The *Hubei PBS* First Program operates on 3940 kHz at 0000-0615, 0850-1530, 2125-2400. (WBI 2/12)

The *Xinjiang PBS*, in Urumqi, Chinese service operates 0430-0730 on 9560 (Su only), 7385 (Summer only), 6100, 4500, 3960 (Winter only) and 2560 kHz. Same frequencies are used at 1030-1650 and 2305-0210. The Mongolian/Kirghiz Service operates daily at 0500-0700, 1130-1645, and 2300-0230, all on 4220, 4980 and 5060 kHz. The Uighur service is at 0430-0730, 1030-1650 and 2200-0200, all on 2560, 3990, 4735, 5800, 7195, 9595. The Kazakh service is at 0000-0230, 0530-0700 and 1200-1645, all on 4330, 4970, 5440. (WBI 2/12)

The *Hunan PBS* operates in Chinese on 4990 kHz at 0000-0540, 0855-1500 and 2125-2400. (WBI 2/12)

COLOMBIA - *RCN Internacional*, Bogota, 690 kHz [as heard] with good MOR pops at 0515. *Ondas del Ortega*, Florencia, 4976 kHz, heard with good sigs at 1749 with

announcements of mail for listeners that could be picked up at the station. **R. Buenaventura**, 4833 kHz, at 1802 with announcements and an ID. **La Voz del Guaviare**, San Jose del Guaviare, 6035.2 kHz, fair signals in Quito with music and ID at 1345. **La Voz del Llano**, Villavicencio, 6115.9 kHz, with an ID at 1358. **R. Caracol**, Bogota, 6150 kHz, with news, good signal at 1400. Also on 6170, not // Bogota, at 1404. [La Voz de la Selva, Florencia, 6170 kHz, listed by number under the Caracol Network in WRTH 93.--mf] Also at 1615 UTC on 12300 kHz with an interview, ID and promo. (KMH/QLB/DXPL 1/22)

Radio Nacional noted over RHC on 9655 at 0311, 2/6. (Marie Lamb, NY)
Colombia

The station on 4561.5 kHz reported by Dave Valko as an unid last fall has now been identified by Henrik Klemetz, who is in Bogota. It's **Una Voz en la Frontera**. The address is Cra. 2 No. 1-10, Puerto Santander. (DXSF via HJ)

Armonias de Caqueta has reactivated on 4915.1 kHz; has been heard at 1130. (Dave Valko via HJ)

Reports of a station on 4927 kHz called **R. Tropicales Venuti** are false. The station actually heard was probably the Peruvian **Onda Verde Radio** (see below) (Ekwall in NU via HJ)

La Voz de la Selva has reactivated. Heard on 6170 kHz with good signals during Gifford Pinchot VI. (HJ)

COOK ISLANDS - **R. Cook Islands** is still active on 11760 kHz from 1600-1000. (Kemp in DX'ers Calling via HJ)

COSTA RICA - Adrian Peterson of AWR US visited Costa Rica in January to check on progress of AWR's Latin American base at Cahuita. Two or three SW xmtrs at Cahuita are testing with low power. Several antennas were nearly complete. Studio-xmtr links from Alajuela are being set up. 9722.5 kHz was heard best outside Costa Rica in January [not by me--mf] and will move back to 9725 kHz. 13750 has been testing between *1200-2300*. The studios are at the Adventist University in Alajuela near San Jose. AWR has bought a new building several km. away which will be equipped for studios and occupied gradually in late summer. The 5 kw xmtr on 11870 kHz was still in Alajuela at the end of January. It is to be moved to Guatemala in March or early April. Try around 1200 or 2300 if you want a QSL from Alajuela. (AP and JM on RNMN 2/4)

TIFC, Faro del Caribe (Lighthouse of the Caribbean), San Jose, operates five xmtrs on AM, FM, and SW. A new SW xmtr is nearing completion on the edge of the San Jose-Alajuela-

Heredia metropolitan area. It will begin operation in May. (Adrian Peterson, AWR US, on RNMN 2/4) Noted on 5055 kHz at 0154 with religious program in SS; good signals in Quito. (KMH/QLB/DXPL 1/22)

SW broadcasting to local targets in Central America does not seem as reliable as in other parts of the world. Sometimes electric power supply is a problem. Spare parts may be hard to get and slow to arrive. Much of Central America is very rugged and very hilly. SW is used to fill in areas which AM and FM cannot reach. This works well on the Atlantic coast of Costa Rica. (Adrian Peterson, AWR US, on RNMN 2/4)

ECUADOR - Ecuador reverted to standard time, UTC - 5, at midnight Friday 2/5. (DXPL 2/6)

Adrian Peterson, traveling in Costa Rica at the end of January, heard the Ecuadorian mystery station on 2968 kHz. He's not convinced it's a harmonic, because the freq is not divisible by 10. He did hear several harmonics in the 2 MHz band: **La Voz de los Cuchumatanes**, Huehuetango, Guatemala, 2100 kHz (1050 x 2); **R. Alajuela**, Alajuela, C.R., 2560 kHz (1280 x 2); **R. Puntarenas**, C.R., 2960 kHz (1480 x 2). He heard a lot of stations in the 120 and 90 tropical bands and in between as well: **R. Santa Rosa**, Bolivia, very clear on 4420 morning and evening; Peru on 4485 kHz was also heard clearly; two stations are listed and he did not get a firm ID. Clues in the programs suggest that 2968 kHz is in Ecuador near the Peruvian border. The time zone was UTC-5 [while the rest of Ecuador was on UTC-4.--mf] Both San Francisco and Cuzco were mentioned. At signoff a friend [traveling with Peterson?] who had lived in Peru said "That's not the Peruvian anthem, it sounds like Ecuador." ID's were scarce. One slogan starts with "Studio". Another slogan sounded like "Radio Munio" or "Radio Munideria." Very difficult copy. (Adrian Peterson on RNMN 2/4) [WRTH 93 lists Radio Minutera, Pascuales, Ecuador, on 1450 kHz, also reported on 1460. Half of 2968 kHz is 1484. Ecuador has a bunch of split-freq MW operations. R. Minutera's call is HCDR2, the same district as Guayaquil. Guayas province extends down both sides of the big river mouth to a point south of Cuenca, about 50 miles from Peru. Wish I had a good road map.--mf]

Centinela del Sur, Loja, on new 4771 kHz, with Spanish disco music, pop music and ads at 1810. **R. Popular, Cuenca**, 4800 kHz at 1805, playing the [Dead March from Saul?] with funeral announcements alternating with very upbeat commercials. **R. Catolica Nacional**, Quito, 5030 kHz, with EZL at 0150; MW outlet was silent; started letterbox program. **R.**

Nacional Progreso, Loja, 5060.6 kHz with music at 2345 and a very good signal. (MH/QLB/DXPL 1/22)

R. Francisco de Orellana, has been heard on 2060 kHz, 2 x 1030. (Klemetz DXSF via HJ)

New **R. Runacunapac**, 2967.7 kHz, is the same one that is listed on 1510 khz in the WRTH. Very strong in the mornings but also audible in the evenings. (Moore FT via HJ)

La Voz de Rio Tarqui heard on 3290 kHz instead of 3285, but announcing 3295. (Gaviria Play DX via HJ) Seems to be back on 3285 now. (HJ)

R. Popular has reactivated on 4800 kHz. (Dave Valko via HJ)

R. Interoceanica, 4840 kHz. When Ecuador opened oilfields in the jungle area called Oriente, people moved along and cleared land near the so called oilroad. The Pacto church has operated intensively with people in these areas and a number of congregations have appeared. In these inaccessible areas east of the Andes communication conditions are difficult. Therefore the Pacto church has concentrated efforts to build up a local radio station, **Radio Interoceanica**. People in the Oriente area feel a bit forgotten by the rest of the country and therefore the station plays an important role. The station broadcasts in more languages including Quechua and Spanish. The programs are very much appreciated. Mornings and evenings Radio Interoceanica, from the town of Santa Rosa, transmits on SW to reach the really inaccessible areas. Other times, the FM band is used. The programs consist of news, cookery tips, health tips, sports, music, education, culture and church services. At certain times during the day "mensajes" are broadcast. The aim is to be "the voice of the people" and help people to communicate with each other. Radio Interoceanica is run by the central organization, and a station manager and a technician are employed. The programs are produced by freelance employees and volunteers. Now the station has to be self-financing, and they have plans to introduce commercials. (Swedish "Mission" in SWB translated by Finn Krone in DSWCI via HJ)

R. Federacion noted on 5985 kHz mornings but not // to 4960. (Gaviria Play DX via HJ)

EL SALVADOR - As mentioned previously, ex-clandestine stations, **R. Venceremos** & **R. Farabundo Marti** are now official stations. Due to technical problems the SW xmtr on 6300v (5 kW) has been out of action since August 1992, it is located in Guacamaya. So only on FM at the moment. R Farabundo Marti also only on FM but plans to re-start on SW for Salvadorans living abroad. (Takayuki Inoue Nozaki, in Onda Corta Jan 1993 via ADXN) **R. Venceremos**, 6300 kHz, plans to return to shortwave to broadcast to Salvadorans living abroad. The station's slogan

is "Una emisora diferente para una Nacion en cambio" (TIN in Onda Corta via DXSF via HJ)

GEORGIA - **R. Tbilisi** was heard in Japan late in January at 1600-1630 on 9565 kHz. Reception was poor. The program was in EE. The station ID was "This is Georgia." A program in RR followed from 1630-1700. (Yoshinori Kato on RJMR 2/14)

GUAM - **KTWR** sked changes for Z93 (from 3/28): on new 9870, ex 12025 Indonesian at 2045-2230; 11580 Hindi (new lang) 1530-1600; 15485 Burmese (new lang) 2330-2400. (Bob Padula via ADXN)

GUATEMALA - Radio Reloj operates 24 hrs on 730, 4832 & 6006 kHz. (WBI 2/5)

HONG KONG - There will be yacht races this year from 0400 on April 3rd to the 8th. Look for race communications on 4060 with 2638 as a backup. Position reports will be broadcast at 0833 and 2333. (Fodge info on DX Daily via HJ) During the South China Sea Yacht races **Radio TV Hong Kong** has been on 3940 kHz with 2 kw broadcasting weather for the race participants. (Magne in DXO) These English broadcasts should last about 40 minutes and can be expected to start between 1100 and 1130 and again at between 2300 and 2330. (Clark in DXO)

INDIA - **AIR** recent variations: 2245-0045 GOS to Asia 11785 ex 11715; 1000-1100 GOS to ANZ 17387 (additional freq); 1115-1215 Tamil 11715 ex 9550; 1615-1730 HI 7412/11620 (additional freqs), 15080 ex 15120. (Bob Padula via ADXN)

AIR Gangtok's only allocation for its 10 kw transmitter is 3390 kHz for regular service. Several of us have tentatively heard Gangtok testing on 4775, including relay of the National Hookup news in Hindi and English at 0030-0040. At deadline I was in the process of trying to confirm with Manosij that what we were hearing in late-Jan and early Feb was in fact Gangtok from the exotic former Kingdom of Sikkim. (Dave Clark in ODXN quoting Manosji Guha) **AIR Gangtok** in the former Himalayan Kingdom with English news at 0030-0040 on 4775. Frequency is on the air from 0000-0430, 1130-1800; and on 3990 from 0000-0400 and 1415-1730. The address is AIR Installation Engineer, old MLA Hostel, Gangtok 737 101, Sikkim. (Bushel in RIAS DX via DSWCI via HJ)

AIR Calcutta has returned to shortwave with a new 50 kW transmitter. Watch for this on 4820 from 1200 s/on in the morning or at 0025 s/on in the evening. (MG/DMC)

AIR Hyderabad has also been upgraded from 10 to 50 kW and was testing in January.

Check for this one on 4800 with same s/on times as for Calcutta. (MG/DMC)

AIR Imphal - The new 50 kW transmitter has been noted testing during local afternoons on 7130. Other allocated test frequencies to watch are 6035 and 9650. (MG/DMC)

AIR Madras has also been upgraded from 10 to 50 kW. The primary frequency for this one is 4920 from 1200 s/on in the morning and 0015 s/on in the evening. (MG/DMC)

AIR Thiruvananthapuram has suspended tests of its new 50 kW transmitter, pending evaluation. Regular service channels have not been stated as yet. (MG/DMC)

India BroadBase, a joint publication of India's Universal DX League and ODXA, is now available from ODXA for \$8 + postage. (DMC)

INDONESIA - **RRI Jambi** noted on 1925 kHz from before 1100 to after 1610. (Toru Yamashita via Tsutomu Kito, Japan) 1030-1700*. (Juichi Yamada, Japan)

RRI Parangkaraya, 3324.9, has an English lesson Mondays at 1435-1455. (Juichi Yamada)

RRI Nabire heard again since 2/1 on 5055.3 kHz at 1100*, and on 6127.5 kHz at 1100-1500. (Juichi Yamada, Japan)

RRI Jayapura (Irian Jaya) has been reactivated on old 9612.4 kHz, opening up at or soon after 1300. Prior to then it is still on 6069.8 kHz. The carrier level is quite good but modulation (except sometimes when the 1300 Jakarta news relay is picked up) is at a very low level. This was typically the case on the presently inactive 5044.8 frequency, too. Not listed in 1993 WRTH - the transmitter has in the past been understood to be rated at 7.5 kW; first noted 2/6. (Dave Clark in ODXA)

RRI Samarinda has recently extended its schedule on 9614.4 kHz. Instead of signing off around 0930 it has been running past 1400 when it runs a 9 note interval signal for a full minute, followed by local or provincial news. (Dave Clark in ODXN)

RPDT2 Poso, 350 watts, is the station on 3580. Uses a 41 meter antenna 21 meters off the ground. V/s is Joseph Tinagari, Kepala Stasiun. (Kusalik NU via HJ)

RRI Pontianak reactivated 3395 kHz, heard around 1200. Country chasers note that this is one of the few stations located in Borneo. (Clark FT via HJ)

IRAN (Clandestine) - **R. Voice of Mojahed** was heard in Japan on 10/19/92 despite heavy jamming on 6220 kHz, alternating every few minutes with 6260 kHz. The station gave a mailing address in London. Nobuyoshi Aoi sent a tape of his reception and received a QSL letter signed by Mr. Zore Amin. The xmtr is located in Iraq near the Iran border. It is sponsored by the People's Mojahedin organization of Iran. Programs include news, culture, discussion and

interviews. The station operates 10 hours daily on MW and SW. [no freqs given.] The mailing address is: MISS NB, Box 9720, London WC1N 3XX. (Nobuyoshi Aoi on RJMR 2/14)

IRAQ - The service to South Asia is the most regular of any Baghdad external operations. Reception has been very steady in Sri Lanka for the EE service beamed to India and Pakistan at 1400-1700 on 15250 kHz. Baghdad's home service in AA settled on new 4605 kHz after trying several channels in the 60m band. Heard in Sri Lanka from *1400-0035*. (VG on RNMN 2/4)

The **Voice of Iraqi Kurdistan** announced 1/30 it would operate 1400-1700 on 1600 MW and on SW. Current SW is 4180v kHz. No date was given for the sked. (WBI 2/12)

IRELAND - The following letter (excerpted in part) was recently received from the Irish Minister for Tourism, Transport and Communications: "We in the Department as well as RTE [Radio Telefis Eirann] have always been conscious of the desires of Irish people abroad to receive an Irish radio service. Over the past few months, RTE have been reviewing again the implications as regards cost and programming of such a service. In addition to the cost of organizing special programming, RTE estimates that a shortwave service would cost at least six million pounds to establish. Furthermore, most domestic receivers cannot receive a short wave signal and even if such a signal was picked up, the quality of reception would be poor. It is for these reasons the RTE feel that shortwave does not offer the best option for the future.

"By way of an alternative, RTE is currently investigating the possible use of satellite to get its services into Europe...". So much for the prospect of an official Irish shortwave service. (Peter Whister on Internet BBS via Ben Krepp on CompuServe, via ODXA)

JAPAN - The seventh 300 kw xmtr at Yamata engaged in extensive testing during February, using 1960's EZL music and announcements in JJ by a woman (not mentioning Radio Japan or NHK) about every five minutes. The test sked included: 0700-0855 on 7140 kHz; 0900-1055 on 6185 kHz; 1100-1255 on 15340 kHz. (AC on RNZI 2/4) Tests for the last new 300 kw xmtr at Yamata were cut back 2/1. The shortened sked effective until about 2/25 was: 1300-1400 on 7140 kHz, 1500-1600 on 9580 kHz, 1605-1705 on 17765 kHz, 1710-1810 on 6185 kHz, 1815-1915 on 11815 kHz, 1920-2020 on 15430 kHz, and 2025-2125 on 21610 kHz. (Tooru Yamashita on RJMR 2/14)

Ian MacFarland's two years as a consultant to Radio Japan end late this month. However, he will continue his monthly series of

interviews with personalities from major SW stations. [I knew he wouldn't retire. - mf] Also, Larry Magne will resume the receiver test reports he had been doing for DX Corner when Kaz Masuda was presenter; these will be heard the last Sunday of every month beginning in April. (RJMR 2/7)

R. Japan placed a new computer-based operations center in service 2/1. It replaces a tape-based system installed in 1973, when RJ was broadcasting 37 hours of programs a day. The February 1993 figure is 52 1/2 hours; it will rise to 60 hours in April. The new system, which uses two computers, replaces three separate systems. All feature programs are first recorded on tape. Then the tape is stored on a computer disk as an audio file. The old system used broadcast cartridges (20 or 40 min of tape on a single reel). Live shows like "This Week" are taped and saved as audio files at the same time. Digital disks give better sound quality and avoid tape breaks during a broadcast. Clicks and pops caused by control signals between programs have disappeared. Digital disks can hold 99 min 59 sec of program each. The new system lets RJ break in with live news while an audio file is playing. One computer also schedules the use of RJ's ten studios, replacing a control operator. (RJMR 2/4)

KASHMIR (Clandestine) - The *Voice of Independent Kashmir*, which opposes the present government of India, began broadcasting in Urdu and Kashmiri in 2/91. The Urdu ID sounds like "Ni sera i hurriyat i Kashmir hai." Xmt power seems to be about 10 kw. The address is P.O. Box 102, Muzaffarabad, Azad Kashmir, Pakistan. The sked is: 0230-0330 on 5000, 5860 and 6300 kHz; 0700-0800 on 5000, 7300 and 7375 kHz; 1630-1730 on 4080 and 6300 kHz. A typical service includes an opening announcement, a reading from the Koran, news in Urdu and Kashmiri, a commentary, a transcription service, and national songs. (Nobuyoshi Aoi, visiting Pakistan 12/92, on RJMR 1/22) But it's being heard in Sri Lanka on 4115 kHz, ex 4080. Reception is fair from 1530-1630 in Sri Lanka. EE was added on 2/2 from 1530-1600, including an EE ID as "Voice of Independent Kashmir." (VG on RNMN 2/4)

R. Kashmir, Srinigar, noted s/on at 0115 instead of 0120 on 3277 kHz. (Clark NU via HJ)

KIRGHIZIA - 4010 *Kirghiz Radio*, Bishkek has English news on 4010 kHz at 0010-0015; //6080. (RVI in DSWCI via HJ)

KOREA (North) - WRTH 93 says *Pyongyang B/c Station* on 3250 kHz is silent 0830-1500. However, I have been hearing heavily jammed programs on 3250 between 1300 and 1500. The jammer sounds like an industrial engine. This may be a new clandestine aimed at

South Korea, or, possibly, South Korea trying to use a freq available on North Korea's fixed-tuned receivers. (Mike Fern--CA)

Radio Pyongyang schedule is now 0700-0750 Chinese on 15180 (ex 13650); 2300-2350 and 0000-0050 English on 11335, 13760 and 15130 (ex 15115). (Toru Yamashita via Tsutomu Kito, Japan)

LEBANON - *University Network* is now broadcasting from Lebanon to Russia between 1230-1630 on Wings of Hope, 11530 kHz. (Gene Scott 2/16)

High Adventure Ministries still has only two SW xmtrs, 6280 and 11530/9895 kHz. However, a second MW xmtr will be added this year. (George Otis and John Tayloe, High Adventure Ministries, via Mike Fern--CA)

LITHUANIA - *R. Vilnius* noted on new 9530 kHz; //9710. Station has suffered from a power shortage since 11/17. Shortwave has been cut from 20.5 hours a day to 4 hours. *Radio Centras* (9710) has now dropped shortwave due to power shortages and financial difficulties. (FB and WB DSWCI via HJ)

MARIANAS - *KHBI*, Saipan, was silent from 1/2 to 1/20 because of construction. The station resumed its sked gradually between 1/21 and 1/24. (Yoshiaki Hayashi on RJMR 1/31) Much better signals at 0000 and 1600 in Sri Lanka after antenna maintenance. (VG on RNMN 2/4)

MONACO - *Radio Blagovest* broadcasts in Russian via Monte Carlo at 0730-0800 (Su) on 12020; 1850-1950 daily on 7385 kHz. The TWR sked doesn't these transmissions. Address is Centre Sts. Cyril and Methodius, A.S.B.L. Rue de l'Association 32-34, B-1000 Brussels. (Nikolai Rudnev)

MOROCCO - The new VOA relay base near Tangier is nearly ready. VOA hopes to begin limited transmissions from that site in June on two of the ten 500 kw xmtrs. The first antennas to be ready are directed toward Africa. Staff at the old site is being trained to operate the new equipment. The old site will be closed down as soon as the new site can take up the workload. (Bill Whitacre, VOA, and JM on RNMN 2/18)

NAMIBIA - *Namibian Broadcasting Corp.* was being heard in January on an unlisted frequency of 4965 from 0435 in English with ID at 0500. (WOR)...could be subject to seasonal change at the end of March. (Dave Clark in ODXN) *NBC* noted with English news on new 6175 kHz at 0600. (FST in DSWCI via HJ)

NETHERLANDS - *Radio Netherlands* English for Z-93 (Apr-Sep) is 2330 on F6020 and B6165 to North America; 0030 on F6020, B6165, B11835 (AM-compatible USB) to North America

M11655, M9860, F13700, A9825 to Asia; 0130 on M11655, M9860, F13700, A12025 to Asia. 0230 on M11655, M9860, F13700, A12025 to Asia. 0330 on B9590 and B6165 kHz for Western North America. 0730 on B11895 & B9630 to Pacific. 0830 on B11895 kHz to the Pacific. 0930 on B11895 & B9720 kHz to the Pacific; 115470, P12065 to Far East. 1030 on 115470, P12065 to Far East. 1130 on F5955 & F9855 kHz to Europe. 1230 on F5955 & F9855 kHz to Europe. 1330 on F17610, M15145, F13700, M9890 to South Asia. 1430 F17610, M15150, F13700, M9890 to South Asia. 1530 on F17610, M15150, F13700, M9890 to South Asia. 1730 on B21590, B21515, M7120, M6020 to East, West and Southern Africa. 1830 on B21590, B21515, M7120, M6020 to East, West and Southern Africa. 1930 on B21590, B17605 (AM compatible USB) to West Africa. The above frequencies are subject to change depending on interference. RN Transmitter site info: F=Flevoland Holland, B=Bonaire, M=Madagascar. Commonwealth of Independent States sites: A= Alma Ata, I=Irkutsk, P=Petrovskoye Kamchatski. (Jonathan Marks in *On Target* posted to Usenet's rec.radio.shortwave newsgroup.)

NEW ZEALAND - When New Zealand reverts to GMT+12 on 3/22, 15120 kHz will be used at 1850-0658. 17770 kHz will be dropped. Changes in the 31m freqs are expected on May 5. (Tony King on RNZI 2/4) The full sked from 3/22 will be: 1640-1850 on 9675 kHz, 1850-0700 on 15120 kHz; 0700-1207 on 9700 kHz. (AC on RNMN 2/11)

NORWAY - *Radio Norway's* last Saturday English transmission was January 30th. English is now on Sundays only. (Southwell in DSWCI via HJ)

PAPUA NEW GUINEA - The long inactive 9520 kHz outlet may return to the air in 1993. The 2 kw transmitter on 3925 kHz is testing intermittently, and could return to a regular schedule in March. (Gordon Darling, via Dave Clark in ODXN)

BBC Monitoring reports hearing an item on R. Australia to the effect that the PNG government is considering making Pidgin the "primary language" of the country. In the future, this might mean we will hear less English and more Pidgin on the various NBC stations. (WOR via ODXA)

PERU - *R. Chota*, 4835 kHz at 1757 with an invitation to write to the station and then sign off at 1759.

R. Cora del Peru, Lima, 4915 kHz, with political messages, ads, etc. at 0234.

R. Tropical, Tarapoto, 4935 kHz, with ad, music, sports promo; good signal in Quito at 0218.

R. Ancash, Huaraz, 4991 kHz, at 0157 with music.

R. Quillabamba on new 5022 kHz at 0140 with music and announcements.

R. Estacion C, Moyobamba on new 6330 kHz with ads, time check, and announcements for Ecuador residents (in Santo Domingo de los Colorados); reception was only fair at 1450. Thanks to the NASWA Journal for ID'ing this one, which has moved from the freq in PWBR 92. [WRTH 93 has 6330 kHz and 1030-0200--mf]

R. Tacna, 6571 kHz, at 1325 with poor signal. *R. Sensacion*, Huancabamba, 6895.2 kHz, at 1426 with music and news. (KMH/QLB/DXPL 1/22)

R. Altura has reactivated on 3339 kHz and has been heard both mornings and evenings. (Dave Valko via HJ)

R. Mundial is a new station located in Celendin on 3871 kHz. Slogan is "La voz de la Esperanza". (CDS in Onda Corta via DXSF via HJ)

R. Internacional is a new station heard on 3402 kHz. (HJ)

R. Naylamp reactivated on 4299.7 kHz. Heard at 1017 with Huanyos. Station has not been heard since last July when it was on 4110 kHz. (HJ)

The station on 4593.5 kHz, first heard by Dave Valko and myself this fall, has been identified as *Estacion X* in Yurimaguas. The slogan is *La radio de la juventud*. The former frequency is 4541.3 (Klemetz DXSF via HJ)

Seldom reported *Estacion Laser* is being heard with fairly good signals here from around 1000 till 1100 fade out on 4704.83 kHz. The station has also been noted signing on at 1100 and this is the best time to get an id. (HJ)

Onda Verde Radio heard on new 4944.54 kHz at 1027 on 2/12. A good time to get an id is around 1030 when they often have a block of ads, including one with a baby crying. Listen for the Onda Verde jingle after the ad block. (HJ) Onda Verde Radio is located in the town of Pichinaki, which is in the departamento of Junin halfway between La Merced and Satipo. The station is also on 89.7 mhz FM. (Klemetz DXSF via HJ)

Estacion Tarapoto has been drifting down and is heard on 5014.4 kHz, rather than on 5015.6. (HJ)

The station on 5046.4 kHz is *Estacion Yurimaguas* in Loreto heard signing on around 1045. (Klemetz Play Dx via HJ) Heard here at good level. (HJ)

R. Mundo, 5082 kHz; the station slogan is *La Voz del Pueblo*. (Martinsson in SWB via Play DX via HJ)

R. Tayabamba, 5241v kHz; slogan is "una voz ancashina para el Peru y America. (CDS in Onda Corta via DXSF via HJ)

Difficult to hear *R. Origen* has been logged by Dave Valko signing on with

announcements and an ID at 1100, 5323.6 kHz. (HJ)

R. Popular, 5486.6 kHz, is a new station first heard by me on 1/28 and IDd by Dave Valko a few days later. Heard in our local evenings with American rock and widely varying sign off times from 0030 to after 0300. Not totally sure if this is a Peruvian but mentions of Bambamarca have been heard. (HJ)

An unid station on 5602.7 kHz, located probably in Puerto Maldonado, calling itself *1160 al rojo vivo, mi radio* (Red-hot 1160, my radio). (Klemetz Play DX via HJ) This one is heard in our mornings but no ID so far. (HJ)

The morning program of **R. Tawantinsuyo**, 6173.8 kHz, is "Antena Informativa". (HJ)

R. Oriente has reactivated 6190 kHz; heard around 1020. (HJ) The station has a new transmitter. (Gaviria Play DX via HJ)

R. Azangaro, 7064v kHz, is inactive. (HJ)

R. Nor Peruana rarely reported but heard in Colombia on 9655 kHz. (Gaviria Play DX via HJ)

R. Cobriza 2000 has left the air and the owner indicated that he would return to the air from another location. (Klemetz DXSF via HJ)

PHILIPPINES - **FECB** ceased broadcasts in Russian 1/3 after broadcasting gospel programming to the Soviet Union for about 45 years. Last year GEI also ceased broadcasts in Russian. Two MW outlets in South Korea, AZ and HLKX, stopped Russian services, too. **FECB** Radio International is planning to build its own transmitter site within Russia. (Nikolai Rudnev)

Radio DCB-2 Radio Mindoro logged at 2220 on 3329.8 kHz. (Tikkanen in Finland DX Club via Play DX via HJ)

A new address for **R.Pilipinas**, 15190 kHz, is: PIA Building Visayas Ave. Quezon City, PI (Schulze FT via HJ)

PORTUGAL - **Voice of Orthodoxy** broadcasts in Russian via RTE Sines at 0500-0530 (Su) on 9690 kHz; 1100-1130 (Su) on 9670; and 1630-1700 (Sa) on 9670. Serifies with a detailed QSL. Address is B.P. 416-08, 75366 Paris, Cedex 08. (Nikolai Rudnev)

QATAR - **QBC** on new 9751.3 kHz in Arabic at 2022. Ex 9715. (VT DSWCI via HJ)

RUSSIA - **Far East Christian Broadcasting**, Khabarovsk, is being heard with RR 0800-1100 and KK 1100-1200 on new 4060 ex 9560. (Tutomu Kito on RJMR 1/30) **FECB** has dropped JJ from its opening announcements on 4060 kHz. It was to start KK from 1400-1900 on 783 kHz MW on Feb. 1, according to technicians at **FECB** Korea. (Toru Yamashita on RJMR 1/31) [WRTH 93 under Russia says 783 kHz is 1200 kw, possibly at Blagoveschensk,

carrying the Ostankino #1 network; the WRTH Asia-Pacific MW freq list says 75 kw at Spassk-Dalny. The latter may be pre-coup disinformation. 4060 not heard on West Coast because of teletype QRM.-- mf] **FECB** has added 648 kHz MW to its Korean service. It was heard in Japan at 2005-2100 2/9. It was first scheduled to begin 12/1 at 1400-1900 on 783 kHz, but did not get on the air then. Programs are produced by **FECB** Korea in Seoul. (Toru Yamashita on RJMR 2/14)

The **Voice of America** began broadcasting 1/11 in Korean 1300-1330 and Special English 1300-1400 via Vladivostok on 648 MW using 1000 kw and a directional antenna. The same xmtr also carries Russia's external service in CC and Korean. The service was still in the experimental stage in mid-January, with improvements being made to the satellite link, according to Kim Andrew Elliott of the VOA. (Shigenori Aoki and Yoshinori Kato on RJMR 1/22)

The VOA Frequency Division BBS gave this sked for VOA relays via Russian transmitters: 1300-1330 on 648 kHz Usseiyysk, 1000 kw, 230 degrees, Korean; 1330-1400 on 648 kHz Usseiyysk, 1000 kw, 230 deg, English. 1400-1500 on 5945 kHz Irkutsk, 1000 kw, 152 deg, Mandarin. 1400-1600 on 5925 kHz Novosibirsk, 200 kw, 111 deg, Mandarin. 2130-2200 on 7300 kHz Petropavlovsk-Kamchatsky, 250 kw, 244 deg, Korean. 2200-2300 on 5925 kHz Irkutsk, 1000 kw, 152 deg, Mandarin.

Rukhi Meroc (Spiritual Heritage, a broadcast from the Moscow Islamic Center) is transmitted Fridays in Tatar on 1089, 4055, 7155, 9620, 12075 & 17890 kHz. (WBI 2/5)

Special QSL cards for **Radio Netherlands International's** new relays at Petropavlovsk and Chita went to the printer about 2/15. (RNMN 2/4)

Radio Yunost (Youth Radio), 6080 kHz, apparently via Komsomolsk, heard with excellent signals in CA at 1430 with rock that is almost subcontinental. The word is spelled Y-u-n-o-s-t but the announcer pronounces it as if it were U-n-i-s. We went through this last year. Listeners who want to specialize in the USSR should study the difference between St. Petersburg Russian, probably the Received Standard, and Moscow RR which might be a dialect. (Mike Fern--CA)

Radio Nadezhda lists this sked as of 3/7: 0800-1100 on 630, 7235, 15460; 1100-1400 on 9525, 9590, 11665; 1500-1800 on 1440, 7390, 9490, 11870, 1910, 17675; 1800-2100 on 1440; 2000-2300 on 1215 & 5905 kHz. (Nikolai Rudnev, Russia)

Radio Radonezh operates 1600-1700 on 7230 kHz & 1900-2000 on 846 MW. (Nikolai Rudnev)

Radio Alpha and Omega now operates 1400-1600 (ex 1500-1600) on 9795 kHz. (Nikolai Rudnev)

Radio 7, a new independent station in Samara, broadcasts in Russian, Tatar, Mordov, Chuvash, German, Polish and Yiddish, starting at 0500 and 1300, on 6115 kHz, via a 5 kw transmitter at Zhigulevsk. The address is ul. Gagarina 6A, 443079 Samara. (Nikolai Rudnev)

Radio Shark is noted on new 6185 kHz at 0200-2000. (Nikolai Rudnev)

Radio Chita noted on 4860 kHz at 2110 commencing local programming. It uses a low power transmitter at Atamanovka, approximately 25 km south east of Chita. (Nikolai Rudnev)

Radio Krasnoyarsk has been noted on 5290 kHz at 2320 with local programming; well heard here in the European part of Russia. (Nikolai Rudnev)

Radio Tyumen heard on 4895 kHz at 0110 with local news and press review, //4820 kHz. (Nikolai Rudnev)

Radio Arkhangelsk observed on 5015 kHz at 0400 & 1520 on weekdays. Often has strong co-channel QRM from Ashkhabad. (Nikolai Rudnev)

Radio Murmansk is heard on 5930 kHz at 0400. The evening program - after 1500 - is impossible due to heavy QRM from Radio Prague. (Nikolai Rudnev)

Radio Galaxy sked is 2000-2100 in English and Russian on 11880 or 9880 kHz. (WBI 2/12)

University Network is heard on 6070, 6120 and 12040 kHz at various times of the day. The same transmitter seems to be used, changing frequency. (Nikolai Rudnev)

SAO TOME E PRINCIPE - The VOA will begin tests this summer with a 100 kw MW xmtmr on 1530 kHz. Tests will continue for at least a year to determine whether VOA wants to add a more powerful MW xmtmr. The four 100 kw xmtmrs may not go into service until the summer of 1994. (Bill Whitacre and JM on RNMN 2/18)

SLOVAKIA - Current schedule of *Slovak Radio* is: 0230-0257 to America on 11990, 9580, 7345 & 5930 kHz; 1200-1227 to ANZ on 11990, 9505, 7345; 1500-1557 to Eur on 9505, 7345; 2000-2027 to Europe on 9580, 9505 kHz; all in Slovak. From 4/1 the sked will be: 1130-1157 English to ANZ on 11990, 9505, 7345 kHz; 1500-1557 Slovak to Europe on 6055; 1930-1957 Russian to Europe on 9605, 7345, 5960; 2030-2057 English to Europe on 7345; 2100-2127 German to Europe on 9605 & 5960; 2130-2157 French to Europe on 9605, 7345, 5960; 0200-0227 English to Am on 9580, 5930; 0300-0327 French to Am on 11990, 9810, 5930 kHz. (station, via WBI 2/5)

SOMALIA - Radio Rajo (Somali for Radio Hope), in Mogadishu, was first heard on 9540 kHz in 1/93, though the MW service is believed to have started in 12/92. The station is operated by the U.S. military and describes itself as the voice of the Unified Task Force. Most broadcasts are in Somali, with occasional IDs in English. The schedule is 1000-1030 & 1600-1630 on 1480 kHz; 1130-1200 on 9540 kHz. (WBI 2/5)

Two competing stations claim to be the official *Radio Mogadishu*. The outlet supporting Ali Mahdi Mohammed has announced it has begun news in EE at 1415. BBCM, which heard the announcement, said this xmtmr operates on variable freqs between 9200-9600 kHz or 6958-6963 kHz. (Andy Sennitt on RNMN 2/18)

A *Radio Somalia* was noted with English news at 2135 on 4976 kHz. (SK in DSWCI via HJ)

SRI LANKA - The long-delayed construction of a new *Voice of America* relay at Iranawala, a site 55 miles north of Colombo, is expected to begin in March of 1993. According to a spokesman for the United States Information Agency, if there are no further delays the station would be operational in early 1995. (John Mainland's 'Shortwave Report' in Feb/93 New Zealand DX Times) (via ODXA)

Deutsche Welle, Trincomalee, signs on at 1100 on 11865 kHz in Japanese after a site ID in English. (Padula in DSWCI via HJ)

SUDAN - Radio SPLA was heard again on 2/6 in English at 0500-0530, followed by Arabic at 0530-0600, on 9190 kHz. It had not been heard since early October, 1992. The station broadcasts on behalf of the Sudan People's Liberation Army. Programs are hostile to the Sudanese government in Khartoum. (WBI 2/12)

TAIWAN - The new government plans to license more AM and FM stations during the next two years. Applications for a limited number of FM stations will be accepted this year; AM stations will be opened up in 1994. (DXPL 1/30)

THAILAND - Test transmissions from the new *Voice of America* SW relay base at Udorn will begin in the first week of March. Tests will start with two xmtmrs and two antennas. The base has six Marconi 500 kw xmtmrs and a whole bunch of antennas. Test xmsns will be directed both northeast and northwest, towards China and South Asia. Eventually the station will have antennas covering an arc of about 270 degrees from China to the Indian subcontinent. Tests will be mostly tones, possibly some music, and occasionally some live programming. VOA hopes for an official opening some time this summer. Several frequencies have been

authorized for each SW band and time periods have been chosen for a minimum of interference. "If people hear odd open carriers or tones and things, and the propagation looks right, it may be us." (Bill Whitacre, VOA, and JM on RNMN 2/18)

TURKEY - About 200 pirate FM and TV stations sprang up in Turkey following a government announcement last June that broadcasting policy would be liberalized. Present law allows only the government-sponsored TRT to operate. Officials claim that FM pirates are interfering with aircraft, armed services, and police circuits. Officials want to shut the pirates down, but the broadcasters have said they will resist. Osman Ataman, secretary-general of the Association of Radio Operators, said he hoped their defiance would speed up proposed legislation to allow private broadcasting. The Interior Ministry asked provincial governors 2/1 to close private radio and TV networks and press criminal charges against their owners. Broadcasters said 100 stations in five provinces, many of them allegedly run by ham operators, had been shut. Three Istanbul FM stations closed down voluntarily. (DXPL 2/7)

UNITED KINGDOM - The *BBC* began a new series of international radio and TV phone-ins at 1400 2/14. India's Prime Minister Narasima Rao was the first guest. The new series is produced jointly with BBC World Service TV and is broadcast in two languages (e.g. English and Hindi) at the same time. India has the largest BBC World Service radio audience of any country in the world when one takes both Hindi and EE together. The same seems to be true for BBC World Service TV although it has been going for only 18 months.

BBC's task force for the 2/14 broadcast included telephone operators who spoke both English and Hindi. The TV studio in Delhi was joined to Bush House by a one-way satellite TV link through BBC's London TV Center. Broadcast sound and listeners with questions used ordinary telephone land line [as heard]. The prime minister saw the London presenter, Sheila MacDonald, on an ordinary TV set in the Delhi studio. Listeners' questions were written on large color-coded cards so everyone in the main London studio could follow the action by the colors. A computer holding information about the callers was linked to the graphics department at BBC's TV Center which prepared maps showing where each caller was and the caller's name. Separate groups of translators in different studios were used for instantaneous translation from Hindi into EE and vice versa. (BBC Waveguide 2/15)

Pirate station *Voice of the Leek* reactivated on 7490 kHz. Heard before 1000. (Campbell DXSF via HJ)

U.S.A. - Dr. Kim Andrew Elliott, head of VOA audience research, is currently overhauling the way that station handles its mail. (RNMN 2/14)

The Voice of America's Brazilian service has survived since 1987 by creating new services. Every 60 min via satellite VOA provides newscasts to hundreds of Brazilian AM and FM stations. Nils Lindquist, chief of the Brazilian branch, tells how the 13-person unit works.

NL: Our service begins at 0930 and continues to 2300. We are on the satellite every hour on the half hour with a variety of news and information packages.

JM: Actually you're putting out more [on satellite] than you ever did on SW.

NL: That's correct. We're doing three hours a day on satellite plus one hour a day on SW which is also on satellite.

JM: Isn't it hard for the VOA to work with commercial networks like Bandeirantes or Globo?

NL: I think VOA has made quite a name for itself in Latin America. It has become known as a very reliable and objective news and information organization. On election night we did 5 1/2 hours on satellite only, a record in the Brazilian branch's 31 years. We did not do an all-night marathon on SW. One network provided us with 145 stations, another with 22.

We are very client-oriented. If we can do whatever the client requests, and as long as it's within our charter, our mandate, we are more than happy, we will bend over backwards to do it.

JM: The charter is very vague, isn't it?

NL: I guess everyone has their own interpretation of it. As long as you remain objective, as long as you explore and talk about America as a whole, but not any individual group, I think you can accomplish your purpose. Right now we bring in two persons at 1:30 a.m. Washington time to prepare a 15-min program for one station in Brasilia that goes on the air at 5 a.m. That's a big drag on our short resources. That one station in Brasilia probably has a rather small audience of 50,000, but it's the cream of the crop.

JM: VOA's Brazilian branch is audible on a separate subcarrier on the WorldNet TV network. It's heard on Intelsat 6, transponder 14.

NL: We have two projects under way right now, one with the University of Sao Paulo, where VOA has provided a grant for the installation of a U.S. manufactured and maintained dish at a cost of \$35,000. We have a project going in Brasilia with Super Radio FM, our best affiliate in the country, where we have gone through a local Brazilian manufacturer. We're doing the same project for about \$12,500. Basically, a four-meter dish.

JM: What about the shortwave? Are you going to switch it off?

NL: It's being talked about. What I would love to do, basically, and speaking for myself and not for the VOA, is to turn off the SW. Give me the savings and the transmitter money and let me buy satellite dishes, or apply that toward some type of new technology. Yes, governments can change in your target area, but I think too that with the proliferation of international broadcasters, -- and we're not the only ones in Brazil: the BBC tries to do a few things. We still like to think that we are way ahead of everybody else. -- With so much international broadcasting into a country that has, right now, for example, in the case of Brazil, extremely open media, it would be very, very difficult for any government at this point to come into Brazil and come back with the strong, strong censorship that we saw in the 60's and 70's. Yes, once you turn off the SW, you'd have a hard time getting your audience back.

But we had some interesting people here from the Globo group a couple of months ago. And Globo for years has maintained very strong, 250 kw basically domestic SW systems. They turned those xmtrs off three months ago, and have yet to receive *one* letter of complaint. I think that says something. You've got 3,000 commercial radio stations in Brazil. That's our audience. That's our target. (RNMN 2/4)

The following sked for Dr. Gene Scott's *University Network* was compiled for Radio Japan Media Roundup by four Japanese DXers. Changes and corrections provided by University Network 1/26 come afterward. The service from Russia began 11/1. In January its sked was extended to 23 hours daily. The service via Russia was first aired from 0400-0800 via Novosibirsk on 15315 kHz [to China] and Samara on 21845 kHz [to India]. However, with the start of the full-day service, 15315 kHz was replaced by 6070, 6120, and 12040 kHz.

From the U.S.: via *KCBI*, Dallas, TX, 1400-2200 on 15375 kHz; 2200-0230 on 15725 kHz; 0230-1400 on 9815 kHz.

Via *KVOH*, Rancho Simi, CA: 0400-0800 on 9785 kHz and 0200-0230 Tues thru Sat on 17775 kHz.

From Anguilla: via the Caribbean Beacon, 24H on 690 and 1610 kHz and 100.1 MHz FM

Via High Adventure Ministries, Marjayoun, Lebanon: to Africa and the Middle East from 0400-0800 on 11530 kHz to Europe, Russia, and the Middle East from 2200-0200 945 kHz MW and on 6280 and 11530 kHz SW. A live broadcast of the Sunday services [1900-2200 Sun and 0400-0800 Mon] can be heard on 104.5 and 105.1 MHz FM. A special communion program is broadcast from 1400-1500 on 11530 kHz and from 1800-1900 on 945 kHz MW, 6280 kHz SW and 104.5 and 105.1 MHz FM. (Shigenori Aoki, Nobuaki Takahashi, and friends on RJMR 1/22)

From Russia: 0100-1100 on 12040 kHz; 1130-1600 on 6070 kHz; 1700-0100 on 6120 kHz, all for China via Novosibirsk. 0400-0800 on 21845 kHz to India via Samara.

From the U.S. via *WWCR*, Nashville, TN: 0100-1400 on 5935 kHz; 1400-0100 on 13845 kHz.

Via High Adventure Ministries, Marjayoun, Lebanon: To Europe, Russia, and the Middle East: 0800-1200 on new 9895 kHz starting 1/24. (University Network 1/26 via mf)

The FCC application for transfer of license of KCBI gives the sale price as one thousand dollars. [Shucks, the NASWA could have bought it.--mf] The Ceylon B/c Corp. paid one pound for the entire BBC South Asian relay station at Ekala, just north of Colombo. It would have cost the BBC more to dismantle it than to simply hand it over. (JM on RNMN 2/11)

WJCR has begun fund raising. In a February 1993 letter from Don Powell to "My Dear Partner" the following information was obtained. March 15th will mark the station's first anniversary. They are using 7490 kHz and 13595 kHz. It's 100,000 watt FM station is known as the Christian Voice of Millerstown. It celebrated its third anniversary on February 5th. "Up until the end of November, we were doing good financially but the last of the year around Christmas time, we suffered quite a loss in just our maintenance expenses to keep these 3 stations on the air. As I write you this letter, it would take Twenty-two thousand dollars to pay our loose bills and expenses up to January 1, 1993. In asking for a contribution the stations proclaims its new motto for 1993: "DEBT FREE IN 1993!" [D'Angelo]

WEWN, Birmingham, AL, returned to the air about 2/5. Each foreign language "hour" is about 55 min. long. An EE program featuring Father Ray is heard from H+55 to H+59. [I am waiting to find out if he has done more than one. - mf] The mailing address used on the air, P.O. Box 100234, Birmingham 35210, differs from that in WRTH 93. (Mike Fern--CA) New phones for *WEWN*, not in *WRTH 93*, are: xmtr site, (205)672-7200; Eternal Word Network, (205)672-8040. (Phil Kersey and BMM on RJMR 2/5)

President Clinton is still searching for an FCC chairman to serve a full seven-year term. Joseph Quello, an incumbent commissioner, has been named acting chairman to give Clinton some time. This means that decisions on the future of the AM band have been put off. 1605-1705 kHz will not be opened to new licensees as early as was first thought. One unsolved problem is where and when to move the low-power traffic stations on 1610 kHz. There will not be enough new car radios

equipped for 1600-1710 kHz for several years, assuming 1710 kHz will be available for traffic stations. The commission also must choose a high-definition TV standard for the U.S. Each system presented to the FCC seems to have its distinct flaws. The president of the National Assn. of Broadcasters, Edward O. Fritz, says digital [satellite?] audio broadcasting could destroy the existing ground-based [AM and FM] systems. The NAB wants a digital system within existing AM or FM bands. (Lou Josephs on RNMN 2/11).

"Those on my staff who don't have a shortwave radio by Friday [2/12], I'm serving notice on you right now, you're terminated." (Gene Scott on University Network at *0500* 2/8) [Scott wants his staff to listen to *him* in their off hours; some people would regard 26 1/2 hours a week of Scott as cruel and unusual punishment, since it's not all new teaching. 26 1/2 is the correct total; Scott normally takes Monday nights PST off, and the University Cathedral Sunday morning service is only 9,000 seconds or 2.5 hours. He acts as his own producer, so recorded bilingual Communion segments in PP, FF, SS and JJ don't let him off the hook. -- mf]

President Clinton's deficit reduction program proposes severe cuts in the budget for the Board for International Broadcasting which oversees Radio Free Europe and Radio Liberty. BBC Monitoring ranks the combination of RFE (which broadcasts to the former Soviet satellite states) and RL (which broadcasts to the former USSR) as the fourth largest SW broadcasting organization in the world, based on program hours. The Clinton budgets would reduce RFE-RL funds by \$60 million in fiscal year (FY) 1994, \$59 million more in FY 1995, and by two hundred eighty-one million dollars in FY 1996. If Congress goes along, RFE and RL would be effectively out of business within five years. (RNMN 2/18)

Herald Broadcasting announced on 2/18 the following changes for **WCSN/WSHB/KHBI** effective Sunday 3/2: To Africa: 2200-2400 on 13770 ex 7510 kHz. To Europe: 1400-1600 on 15665 kHz; 2000-2200 on 13770 ex 7510 kHz and 15665 ex 13770 kHz; 2200-2400 on 13770 ex 7510 kHz. To the Middle East: 2000-2200 on 13770 ex 7510 kHz. To Eastern NA: 2000-2200 on 15665 ex 13770 kHz. To Western NA: 0400-0600 and 0600-0800 on 9455 ex 5850 kHz. To Mexico and the Caribbean: 0400-0600 on 13760 ex 9870 kHz. To Oceania via KHBI, Saipan: 1200-1400 on 9425 ex 15665 kHz; 1800-2000 on 9430 ex 13840 kHz. (Mike Fern--CA)

In addition to **WFLA** Tampa, Florida on 25870 there are some other American stations

operating in this frequency range. Among them heard at around 2200 are: 26250 **WPLG**, TV 10, Miami; 26350 **WSVN** TV 7, Miami; and **KPEZ** FM 92.9 Tulsa. 26450 **WHIO** TV 13 Des Moines. (Roberts CIDX Messenger on DX Daily via HJ)

VIETNAM - A new MW station at Dong Hoi in central Vietnam began broadcasting on 639 kHz January 1 with 200 kw. It began testing on 12/15. The regular sked is 2145-1600, with relays of the *Voice of Viet Nam* home service. The People's Army program is heard Friday only from 1600-1700. (Hanoi newspaper Nhan Dan 12/19 via Isao Ugusa on RJMR 2/14)

5032 The unid station heard around 5032 kHz is in Vietnam. National anthem and news in Vietnamese heard. (Kecskes in DX'ers Calling via HJ)

7287 kHz is a new frequency for the Home Service relay; // 10059. Noted at 1300-1600 and 2130-2300. (WB in DSWCI via HJ)

ZAIRE - R. Bukavu, 4843 kHz, made a most interesting request of Mitch Sams when they sent his QSL: "In regards to our transmitter, please express mail us a new transmitter." (in FT via HJ)

EQUIPMENT - Grov Enterprises has suddenly cancelled its SW-100 receiver project, citing mounting costs as a reason for not following through, according to [unnamed] U.S. computer networks. (RNMN 2/11)

The LCD Crystal Ball - JM: Larry Magne of Passport to World Band Radio believes SW has more life left in it than many people think. It may be old technology, but it's cheap, and satellite portable radios are still on the drawing boards.

LM: The People's Republic of China is producing very low-cost digital synthesized radios. Right now they are poorly made, but quality will pick up as China's industrialization progresses. They are bringing the price down to a fraction of the cost of a Sony or Panasonic. Current Chinese models can run you as little as US\$40. They are being sold throughout the world and I think this is the wave of the future. If all the circuitry can be put on one chip, then \$20 or \$30 radios that perform like today's \$200 radios are not far off. We're not talking about just the advanced prosperous countries. We're talking about Africa, Asia, all the rest of the world, where the question of receivers being usable and handy and easy to operate and decent performing will be past us. We will then be into the new generation of receivers. This won't solve all our problems on SW, but it will go a long way towards helping solve them.

Digital Satellite Broadcasting makes sense when you don't have an infrastructure of Cable

TV. In Japan, Canada, the U.S., and elsewhere we are finding that an infrastructure is being put in to tie every household with fiber optics. There will be, of course, post fiber optic technology which will bring an enormous amount of throughput into every home. Once this is in place, I think you'll find that DBS goes into the history books. DBS is useful in Europe where the infrastructure is still relatively embryonic, and in other parts of the world. Once DBS has to face the wired systems, which will be very low-cost, I think you'll find that the disadvantages of DBS will tend to make that a difficult vehicle to replace SW. If your satellite broadcast goes through a local broadcaster you are again up against the gatekeeper phenomenon. In times of war, in times of crisis, if you have to go through a gatekeeper, you're in trouble. We have to make compromises with the gatekeepers, not money necessarily, but subjects one can't talk about. What is the point of our being here and transmitting these programs if we have to compromise our news in times of crisis? In terms of what you can do as broadcasters to make SW more effective, look again to the low-cost solutions. Frequency management is improving, but it's one area which can be improved at very low cost. (RNMN 2/11) [Sounds like part of his speech at the VOA 50th Birthday conference.--mf]

SILENT KEYS - Harold Henry Beverage, the radio engineer who developed the Beverage antenna and the diversity system for SW reception, died at a hospital on Long Island early in February. He was 99. He held more than 40 patents, and in 1938 the Radio Institute of America [as heard] presented him with its Armstrong Medal for his pioneering work on directional antennas. The diversity system (two receivers, two antennas, one audio output) has been used at many point-to-point stations to reduce fading on incoming signals. One needs plenty of space for a (low-frequency) Beverage antenna; lengths of one kilometer are not uncommon. (JM on RNMN 2/11)

DIGITAL AUDIO BROADCASTING -

Japan sent a delegate, Shozo Ueda, to the 1993 conference of the European Broadcasting Union. He told Ian MacFarland that interest in digital audio broadcasting is high. The BBC, R. France International, Deutsche Welle and R. Netherlands are backing a satellite based system called EuroChannel. This system would broadcast at first in EE, FF, and GG. Transmission standards for the 2.3-2.6 GHz band have to be agreed on. A planning conference is likely before 1999. The growing interest in satellites and DAB means that compatible single sideband, mandated for shortwaves by the ITU several years ago, is on the back burner. Many European broadcasters are not thinking about SSB in 2015 because they

regard compatible SSB as yesterday's technology. (RJMR 2/15)

PIRATES - 6209 Jolly Roger Radio noted here in addition to 6230. (Campbell DXSF via HJ)

6238.8 *Riverside 101* heard by Burnell at 2030 and Valko at 0758. Address per Campbell is Box 101, 166 Spencer Road, Waterside, Derry City, Northern Ireland (NU via HJ)

6295.8 *R. Moonlight* heard at 0845. Address is 14 Stone Row, Coleraine Co., Londonderry, BT52 1EP Northern Ireland. (Monferini Play DX via HJ)

6295 *R. Caroline* best address is P. O. Box 963 London SW20 8XL. (Campbell DXSF via HJ)

6855 *Emerald Radio* has moved here ex 6240. (Campbell DXSF via HJ)

SOURCES - DXPL - DX Party Line, HCJB; JA - John Adams, DXPL; JB - John Beck, DXPL; KMH - Ken MacHarg, DXPL; QLB - Quito Log Book, DXPL; SS - Sergei Sosedkin, DXPL; RMV - Rich McVicar, presenter, DXPL; LMV - Lisa (Mrs. Rich) McVicar, DXPL. RJMR - Radio Japan Media Roundup; BMM - Bruce MacGibbon, RJMR. RNMN - Radio Nederland Media Network; JM - Jonathan Marks, presenter, RNMN; VG - Victor Goonetilleke, RNMN; VS - Valeri Strelnikov, RNMN. RNZI - Radio New Zealand International Mailbox. AC - Arthur Cushen, DXPL, RNMN or RNZI. Above sources monitored by Mike Fern unless otherwise noted. RMWS - Radio Moscow World Service. RSMS - Radio Sweden Media Scan. WOR - World of Radio. SWE - FidoNet's Shortwave Echo. MG/DMC - Manosji Guha/Dave Clark, in ODXN. HJ - Hans Johnson, MD. EB - Ernie Behr, Ontario. Juichi Yamada, Japan ODXN - Ontario DX News. Marie Lamb, NY

DISCLAIMER - I work for VOA but don't represent them here. Back in April. Dan

QSL Reports



Sam Barlo
47 Prospect Place
Bristol, CT 06010

RADYO PILIPINAS

Your report of our English Broadcast on 21,580 Mhz. on Aug. 15, 1991 from 0256 to 0300 U.T.C. has been verified against our log and found to be correct. Please write again. Thank you.

Philippine Broadcasting Service
Maribel Bujing

Philippine Broadcasting Service
Sgt. Eguerra Ave., Quezon City
Philippines

A logo in Copyright of Trans World Radio, Inc.

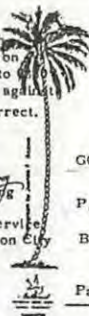

POST CARD

GORDON DARLING

P.O. Box 3474

Boroko, N.C.D.,

Papua New Guinea

ANTIGUA: BBC Caribbean Relay Station 17840 f/d cd. in 59 ds. for 1 IRC. v/s Roy Fleet, Company Manager. (Martin-CA). f/d ltr. in 88 ds. for \$1.00. (Clement-GA). 5975 f/d ltr. in 84 ds. for \$1.00. (Lawrence-NY).

ASCENSION ISLAND: BBC Atlantic Relay Station 17880 f/d form ltr. in 107 ds. for 2 IRCs. v/s Dinah Fowler for Andrew Marsden, Transmitter Engineer. (Brouillette-IL).

ASIATIC RUSSIA: Adventist World Radio 11855 p/d ltr. w/ cd. in 3 mo. (Barto-CT). p/d ltr. w/ XMAS cd. in 98 ds. for a rpt. sent to the Tula addr. v/s Igor Revtov, Coordinator.

This was from Novosibirsk (Stephens-AL).
* FEBC 9560 via Khabarovsk f/d "Khabarovsk, Memorial of Glory" cd. w/ newsletter in 5 wks. v/s Viktor Akhterov. Addr: FEBC, P.O. Box 1, La Mirada, CA 90637. (Howard-CA).

AUSTRALIA: Radio Australia 13705 via Carnarvon f/d ltr. in 51 ds. w/ schedule (Bickus-VA)
VLWG 6140 via Wanneroo f/d cd. in 50 ds. for \$1.00. (Fanderys-OH).

BAHRAIN: Radio Bahrain 9746 p/d "Map" cd. in 49 ds. for 1 IRC and \$1.00. v/s A. Suliman. (Davis-NM).

BOLIVIA: Radio Frontera 4450 f/d prepared cd. * in 11 mo. after a f/up rpt. in SP w/ \$1.00. v/s Lino Miahuchi von Ancken (CP9AR). Also rcvd. 13th anniversary station pennant. (Kohlbrener-PA)...Very nice!...Sam.

BOTSWANA: VOA 15465 via Moepeng Hill f/d cd. in 16 ds. for ms. (Davis-NM). 7265 f/d cd. in 57 ds. (Newhall-CT). 11940 f/d cd. in 6 mo. v/s Dan Ferguson. (Stephens-AL).

BRAZIL: Radio Oito de Setembro ZYG866 2490 * prepared cd. w/ personal ltr. in 42 ds. for a PT rpt. and \$1.00. v/s Adonias Gomes. (D'Angelo-PA). Radio Portal da Amazonia 4775 personal ltr. in 262 ds. for a PT rpt. and \$1.00. v/s Mario Castilho, Director Administrativo. (D'Angelo-PA). Radio Cancao Nova ZYE971 6105 f/d cd. w/ decal in 2 mo. for a PT rpt. (Barto-CT). Radio Bandeirantes ZYE956 6090 f/d form ltr. w/ new style station pennant in 7 wks. for a PT rpt. (Barto-CT).

TRANS WORLD RADIO

ABU DHABI: UAE Radio 13605 f/d brochure in 14 ds. for 3 IRCs. (Carter-WA).

ALASKA: KNLS f/d "Map" cd. w/ schedule and ltr. in 27 ds. for a rpt. mailed to the Franklin, TN office. v/s Mike Osborne, English Language Host. P.O. Box 1468, Franklin, TN 37065. (Stephens-AL).

ALGERIA: Radio Algiers International 17745 f/d "Islamic Art/Logo" cd. in 3 mo. for 3 IRCs. (Carter-WA). Voice of Palestine 15205 via RTVA f/d cd. in 7 mo. for a FR rpt. (Barto-CT).

ANDAMAN ISLANDS: AIR Port Blair 4760 personal ltr. in 2 mo. for \$1.00. v/s K. Muraleedharan, Assistant Engineer. (Lobdell-MA).





NATIONAL
BROADCASTING
COMMISSION OF PAPUA NEW GUINEA

Phone 871144 Cables:
871149

Telex NE87131

P.O. Box 37,
Radio Sandaun,
VANIMO,
Sandaun Province,
Papua New Guinea.

Date: 22nd June, 1992.

CAMEROON: CRTV 3970 via Buea
f/d "Map" cd. in 41 ds. for
ms. and a rpt. in FR-v/s
Ononino Oll Isidore, Chef
Service Technique. (D'Angelo-PA).

CANADA: CFCV 6005 f/d cd. w/
ltr. in 12 ds. for 1 IRC.
Stickers and schedule rcvd.
v/s Jim Connell, Program
Director. (Brouillette-IL).
cd. w/ ltr. in 2 wks. Card
has CIQC and CFQR call ltrs.
(Craighead-KS). **CHIX** 6130
f/d ltr. in 334 ds. for
\$1.00. (Clement-GA). f/d ltr.
in 8½ mo. for \$1.00. v/s
Kurt J. Arseneault, Chief
Engineer. (Clar-NY). f/d ltr.
in 113 ds. for \$1.00. (Com-
eau-MA). f/d ltr. in 11 mo.
for 2 IRCs. (Name?). f/d ltr.
in 307 ds. after a f/up rpt.
(Schwartz-NY). f/d ltr. in
3 mo. (Humenyk-ONT). f/d ltr.
in 10 mo. for \$1.00. (Mill-
ard-TX)...Whats going on?

TO: Kevin Murray,
19790 Suncrest Drive,
West Linn, Or 97068,
U. S. A.

This is to verify that your Reception Report of our station on
Saturday, 22nd May, 1992 is correct in all details.

Our Duty Announcer on that airshift was STANIS R645A
Mr/Mrs/Miss

Thank you for providing us with the Reception Report of our
station in your Country.

Yours faithfully,

GABRIEL DECKVALEN,
STATION MANAGER.

The station must of emptied its mail box...Sam. **Canadian Forces**
Network 15325 via **Sackville** p/d ltr. w/ schedule in 24 ds. v/s
Jean Choquette, Manager of Technical Operations. (Stephens-AL).
CANADA (Pirate): CSIC 15050 f/d "Cartoon" sheet w/ station info.
in 5½ mo. (Stephens-AL).

NOTES: Shawn Fahrer in Howard Beach, NY is very interested in the Spanish numbers station
around 7434.2. It is causing tremendous interference to WOCR on 7435. I would think
so...Sam. **Don Hosmer** says that he was very surprised to get his SLBS OST. The SASE had
2 holes punched in it and was marked "file". Someone must of checked their files and
decided to respond. It took me 10 years on this one!!! Don has his ticket. His call
letters are N8TAV. Nice hearing from you Don...Sam. **Tony Helm** in Kansas City, KS just
completed his new 500 foot beverage. Tony is looking for the site addresses for BBC
Lesotho and BBC Hong Kong. Write him at 4913 Natoma, KS 66106...Sam.

CHINA, PEOPLES REP. OF: Voice of Jinling 4875 p/d "Zhonghua City Gate" cd. in 44 ds. for
\$1.00. (Comeau-MA). p/d "Xuan Wu Lake" cd. in 3 wks. for a taped rpt. and \$1.00. (Lob-
CIS: **Radio Aum Shinrikyo** 9685 f/d cd. w/ religious info. in 18 ds. (Stephens) dell-MA).

CLANDESTINE: Democratic Voice of Burma 15140 via **Radio Norway International** f/d cd. w/
* personal ltr. in 1 mo. for \$1.00. v/s Maung Maung Myint. (Kohlbrener-PA). 17840 f/d
cd. w/ ltr. in 8 wks. for \$1.00. The RNI site is **Kvitepy**. (Craighead-KS). **Voice of**

Freedom 15580 f/d long
personal ltr. in 38 ds.
v/s Daniel Kaszeta,
Assistant Director.
(D'Angelo-PA).

COSTA RICA: TIPC 5055 f/d
cd. w/ ltr. and stamps
in 46 ds. for 1 IRC.
v/s J.J. Ochoa. (Bickus-
VA). **Radio For Peace**
International 15030 and
13630 f/d cd. in 1 mo.
w/ schedule. (Millard).

CZECHOSLOVAKIA: Radio Praha
5960 via **Rimavska Sobota**
f/d "Protected Flora and
Fauna-Lynx" cd. in 24
ds. w/ schedule. (Brou-
illette-IL).

QSL
Verification Card

Station Radio Free Grenada
For Donald M. Hosmer

Thank you for your reception report. We are pleased to verify your reception
of our transmission on 16 May 1992 from 23:53-00:30 hours
GMT/UTC on 15045 kHz with a power of 5000 watts.

X
STUDIO ENGINEER Official Seal

RADIO 4VEH IS PLEASED TO
CONFIRM YOUR RECEPTION REPORT
OF 9-27-91 AT 1055 GMT

ON 49.30 KHZ. 60 METERS

Joan Chabris QSL Secretary

RADIO 4VEH
The Evangelistic Voice
of HAITI

P.O.Box 1
Cap Haitien, HAITI, W.I.
via Kris Field

NOTE: Please re-
member to
write your
name after
each QSL.
You do want
credit don't
you?...Sam.

DOMINICAN REPUBLIC: Radio Cima Cien 4960 f/d "Certificado" style cd. w/ postcard and a commemorative coin and a beautiful banner in 69 ds. for a SP rpt. Also rcvd. a tape of native and traditional music. Best package ever! (Schwartz-NY). same jackpot package in 3 1/2 mo. for \$1.00. v/s Arg. Robert Vargas. (Lobdell-MA).

ECUADOR: HCBJ 11925 f/d "Child" cd. w/ calendar and schedule in 12 wks. for 2 IRCs. (Car-ter-WA). 15155 f/d cd. w/ schedule in 42 ds. (Bickus-VA). HCGOJB 21300 f/d "Logo and Antenna Array" cd. in 39 ds. after a f/up rpt. This is the HCBJ ham station. (Stephens-AL). Radio Paz y Bien 4820 f/d prepared cd. w/ personal ltr. in 39 ds. for ms. and a SP rpt. v/s P. Luis Florencio Leon E., OFM., Gerente-Director. (D'Angelo-PA).

EGYPT: Radio Cairo 9475 f/d "Carved Bust" in 72 ds. after 4 rpts! (Schwartz-NY).

ENGLAND: Radio Canada International 9555 via Skelton f/d cd. w/ pennant in 27 ds. v/s Bill Westehauer. (Yamada-JPN).

ERITREA: Voice of the Broad Masses

* of Eritrea 7280 f/d blue cd. w/ station seal in 2 mo. OSL was mailed from Qatar. v/s Mehretes Tesfagionrgis. Addr: Dept. of Information and Culture, P.O. Box 872, Asmara. (Barto-CT). f/d cd. in 31 ds. for \$1.00. OSL was mailed from Seattle, WA. (Com-eau-MA). f/d cd. in 5 wks. for a taped rpt. and \$1.00. This reply was mailed via Canada! (Lare)

EUROPEAN RUSSIA: Radio Moscow 7150 via Arnavir cd. in 27 ds. (Humenyvk-ONT).

GREETINGS TO LISTENERS
Q. S. L. CARD
SRI LANKA BROADCASTING
CORPORATION
COLOMBO 7, SRI LANKA

Confirming your reception
report of our transmission
on frequency 11835
KHZ in the 25
Meters Band of 11-20
GMT on 26/3/91. Sent 2:12 PM
Thank you for your report.
Sincerely yours,
D. R. H. *Director - Colombo*



POST CARD
Ben Mancine
231 Denison Avenue
Elyria, Ohio
U.S.A. 44035

VERIFICATION SIGNERS: AMR Ekaterinbourg 7310 Miss Suzanne Hoeschele, QSL Secretary. RID Time Station 15004 Fedor Brazhnikov. Addr: Box 3036 Irkutsk 664 059, Russia. Radio Chita 4860 V.A. Klimov, Chief Engineer. SLBC 3316 Joshua Nicol, Special Assistant to the Director of Broadcasting. Radio Tanzania 5050 B.M. Kapings, Director of Broadcasting. RII Palembang 4855 Iskandar Suradilaga. Radio Italia International 7140.1 Nicola Mastro, Owner. Addr: Vicolo Volusio 1, I-06049 Spoleto. Radio Centras 9710 Rimantas Pleikys. Radio Educacion 6185 Luis Ernesto Pi Orozco, Director General. Radio Kaduna 4770 Yusuf Garba, Chief Engineer. Radio Enya 2410 John Lyein Kuk. Radio Tacna 9505 Mrs. Yolanda de Caceres, Directora Gerente. Radio Horizonte 5009 Rafael Alberto Vela Pinedo, Gerente. Ondas del Rio Mayo 6803 Edilberto Lucio Peralta Lozada, Gerente. Radio Tingo Maria 4760 Mrs. Gina de la Cruz R., Administradora. Radio Madre de Dios 4950 Javier Aniz. Radio Oyon 3450 Aurelio Liberato A. Radio Ancash 4991 Roque Moreno Neglia, Gerente Financiero / Dante Moreno Neglia, Gerente de Progr. La Voz de San Antonio 6628 Valentin Mejia Vasquez, Director. Addr: Ap. 34, Bambamarca...Via PLAY DX.

VOICE OF HOPE WORLD NETWORK

We wish to thank you for your reception report. We have found it correct and hereby acknowledge it with this verification card.

King of Hope South Lebanon
 KVOH Los Angeles
 KHBN Guam

WINGS OF HOPE 11:53C via D'Angelo

Date of Reception 3/21/92 Time: GMT/UTC 2:12 - 2:25

Transmission was heard on A 7C - T 4:04

We appreciate your interest in our programs and invite you to write again.

Sincerely yours,
RETE KILLER

High Adventure Ministries THANK YOU FOR YOUR RECEPTION

P.O. BOX 7466
VAN NUYS, CA 91409

submitted by several members

EUROPIRATE: Live Wire Radio

* 6290 f/d cd. w/ sticker and info. sheets in 3 wks. for \$1.00. v/s Bill Lewis. (Kohl-brenner-PA).

FRENCH GUIANA: Radio Beijing

11680 f/d "Velvet Ornament" cd. in 36 ds. for 2 IRCs. (Newhall-CT). Radio Japan 15325 via Montsinyre f/d cd. in 71 ds. for 2 IRCs. v/s K. Hishikawa. (Martin-CA).

GERMANY: VOA 5995 via Wertachtal f/d cd. in 13 ds.(Lare).

GHANA: CBC 4915 f/d cd. in 62 ds. for 2 IRCs.

GREECE: Voice of Greece 17525 f/d (Comeau-MA).

"Santorini Island" cd. in 38 ds. for \$1.00.
Schedule and postcard rcvd.(Comeau-MA).

GUAM: Adventist World Radio 13720 f/d "Koala" cd. in 19 ds. for 2 IRCs. v/s Bob Padula, QSL Manager. This was sent to ADXC for their program.(Yamada-JPN). KSDA 15610 f/d cd. w/ newsletter in 22 ds. for ms.(Brouillette-IL).

GUATEMALA: Radio Buenas Nuevas 4799.8 f/d cd. w/ ltr. and pennant in 45 ds. for a SP rpt. and a tape w/ \$1.00. (Klinck-NY).

HOLLAND: Radio Nederlands 17610 via Flevo f/d "Floral" cd. in 39 ds. for 1 IRC.(Martin-CA). 6020 f/d cd. in 60 ds.(Bickus-VA).

HONG KONG: BBC East Asia Relay Station 11820 f/d prepared cd. in 14 ds. for 2 IRCs. v/s Philip Sandell.(Name?) 15280 f/d ltr. in 27 ds. (Humenyk-ONT). 11820 and 7180 f/d cd. w/ site in 2 mo. for 2 IRCs. v/s H.A. Staiger. This was for a rpt. to the German Service.(Craighead-KS).

HUNGARY: Radio Budapest 9835 f/d "Heviz" cd. in 20 ds.(Schwartz-NY).

**CBC
RADIO**

INDIA: All India Radio 11620 via Bangalore f/d "Elephants" cd. in 53 ds. (Bickus-VA). f/d "Leopard" cd. in 2 mo. for 2 IRCs.(Carter-WA). same

in 52 ds. for \$1.00(returned) (Palmersehl-WA). f/d cd. in 65 ds.(Jones-OH). 17386.9 via Delhi, 21735.1 via Khampur and 15050 via Aligarh p/d cd. w/ schedule in 4 mo.(Barto-CT).

INTERNATIONAL WATERS: Radio Caroline

* 6210 p/d "Ross Revenge" cd. for an 88 reception in 10 ds.(Stephens).

IRAN: IRIB 9022 and 15260 f/d "Shrine of Iman Reza" cd. w/ schedule in 54 ds.(Schwartz-NY).

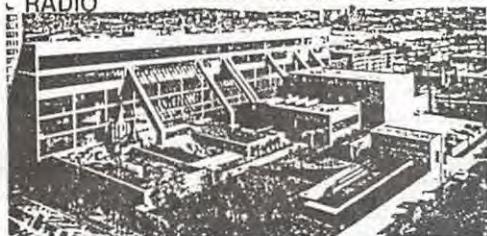

CBC CENTRE - VANCOUVER, BRITISH COLUMBIA

NOTES: Jason Moore in Corbin, KY says that QSLs have been slow in arriving. Did you get your new sloper antenna for XMAS?...Sam. Bill Wilkins reports in from Osan Air Force Base in Korea. Not too much time for DXing. I know the feeling. While I was in Nam and Cambodia there wasn't too much time for DX but what you do hear is extremely interesting such as Australian Forces Radio in Vietnam. Hi!...Sam. Robert Blum in NY was prepared for a long battle to obtain the Radio Pyongyang QSL. Wow - after only one report he received a QSL, pennant, several books and a large stereo record!!! Are you Kim Il Sung's cousin or something?...Sam. Great!

IRELAND: Radio Dublin International 6910 f/d "Logo/Map" cd. w/ info. sheet in 20 ds.

This was after 6 tries for an 82 reception. v/s Eamon Cooke, Director.(Stephens-AL).

ISRAEL: Kol Israel 9435 f/d cd. w/ schedule and sticker in 39 ds.(Jones-OH).

ITALY: Adventist World Radio 7210 via Forli f/d "Antenna" cd. in 1 mo. for \$1.00.(Millard-TX). Italian Radio Relay Service 7125 f/d cd. in 113 ds.(Yamada-JPN). 9815 f/d

cd. w/ schedule in 37 ds. after a f/up rpt. * for ms.(Stephens-AL). Radio Europe 25900 f/d

cd. in 6 wks. w/ sticker and pennant and a personal ltr. for \$1.00. v/s Dario Monferini, QSL Manager.(Kohlbrener-PA). European Christian Radio 6210 f/d "Map" cd. w/ info. sheet in 3 mo. v/s C.R. Coleman, Station Manager.(Stephens-AL).

JAPAN: Radio Japan 9535 f/d "Mt. Fuji" cd. in 20 ds. for \$1.00. v/s Kunitoshi Hishikawa. Also rcvd. schedule and a very good looking NHK handkerchief!(Comeau-MA).

LRA 36

RADIO NACIONAL

via Comeau

"ARCANGEL SAN GABRIEL"

Base ANTARTICA ESPERANZA
TERRITORIO ANTARTICO ARGENTINO
REPUBLICA ARGENTINA

UBICACION GEOGRAFICA

- Lat 63° 24' Sur
- Long 56° 59' Oeste





РАДИО МОСКВА

Dear Mr. Rigas,

This verifies your report on the reception of Radio Moscow's broadcast
in Serbian

Date December 27, 1991

Time 18,59-19,30 UTC

Frequency 4825 kHz-via Kharkov

Best wishes from RADIO MOSCOW

JAPAN: Radio Japan 9535 f/d cd. w/ site as Yamata in 58 ds. for \$1.00. (Clement-GA). **Radio Canada International** 11705 f/d "Canada Council" cd. in 19 ds. w/ pennant, sticker and schedule. (Millard-TX)

KENYA: Voice of Kenya 4934 f/d "Aerogramme" cd. in 78 ds. after a f/up rpt. v/s Lawrence Holnati, Engineering Division. (Stephens-AL)

KOREA, PEOPLES DEMOCRATIC REP: Pyn-gang * **yang Broadcasting Station** 6399.7 via Kanggye f/d cd. in 3 mo. w/ calendar, pennant and a Kim Il Sung book. (Barto-CT).

KOREA, REPUBLIC OF: Radio Korea 15575 f/d "The Farmers Dance" cd. w/ schedule in 20 ds. (Bickus-VA). (Fanderys-OH).

LATVIA: Radio Riga 5935 f/d "Cathedral" cd. w/ info. folder and XMAS cd. in 1 mo.

LEBANON: Wings of Hope 11530 via Hill of the Doves (South Lebanon) f/d "World Coverage Map" cd. in 7 ds. w/ form ltr. from the CA addr. (Davis-NN). same w/ schedule and a personal note w/ stickers in 7 ds. for a taped rpt. v/s Patrick C. Kowalick. (Stephens-AL).

MALAGASY REPUBLIC: Radio Nederland 15570 via Talata-Volonondry f/d cd. w/ schedule and pennant in 9 mo. for ms. Reply direct from site. (Stephens-AL).



NOTES: Mike Franzen says that he recently contacted the VOA to verify specific transmitter sites. He was put in touch with Kim Elliot in the Audience Relations Department. Kim said he would OSL the sites. Address reports to Kim at VOA of America, B/N Room 3131, Washington DC 20547...Mike, just for your information, Kim is an old time standing member in NASWA. Good man...Sam. **Howard Weinstein**, Producer of "Radio Techniques" on WOCR says that he has just seen his first copy of the NASWA Journal. Great stuff! He will OSL 100% but they appreciate \$1.00 or ms. to defray the costs. His address is 15 Lakeside Drive, Marlton, NJ 08053.

MALAWI: Malawi Broadcasting Corp. 3380.6 f/d prepared cd. in 44 ds. for ms. and \$2.00.

MALI: China Radio International 11715 via Bamako f/d "Coconut Hair" cd. (Davis-NN) in only 16 ds: for 1 IRC. Sticker and an anniversary cd. rcvd. (Martin-CA). **Radio Beijing** 9770 f/d "Tiantan Park" cd. in 16 ds. for 1 IRC. (Newhall-CT).

MAURITANIA: ORIM 4845 f/d "Antenna/Logo" cd. w/ personal ltr. in FR in 64 ds. after a f/up rpt. (Fanderys-OH).

MONACO: Trans World Radio 9480 via Mt. Acel f/d "Upper Globe" cd. w/ schedule in 12 ds. (Fanderys-OH).

MOROCCO: Radio TV Marocaine 17815 p/d cd. in 98 ds. for \$1.00. v/s Tanane Mohammed Jamal Eddine, Technical Director. (Lawrence).

NAMIBIA: NBC 3290 f/d "Nature Park" cd. in 37 ds. for \$1.00. v/s P. Schachtsechinder. (Millard-TX).

NEW BRITAIN: Radio West New Britain 3235 p/d ltr. in 49 ds. for a taped rpt. and ms. (Klinck-NY).

NEWFOUNDLAND: CKZN 6160 f/d folder cd. in 81 ds. for \$1.00. (returned) (Gold-MI).



N. Gruce,
40 Woodside Rd.
Harvard, MA
U.S.A.

Moscow, USSR
September 29, 1988

Dear Nicholas,

We have your reception report for our Home Service transmission, thank you for writing.

Unfortunately, we cannot send you a QSL card since Radio Moscow does not transmit on 4765 kHz frequency to North America regularly. It works for Soviet sailors on merchant ships in Central-American waters and for those who know the Russian language.

We will be glad to receive a reception report from you on our transmissions in English beamed to North America. We are now broadcasting in the 13, 16, 19, 22, 25, 31, 41 and 49 meter bands. As soon as our new program guide is off the press, we shall send you a copy.

With best wishes, we are

Sincerely,
S. Stepanova
(Mrs) Eugenia Stepanova
NORTH AMERICAN SERVICE

Radio Gemini

QSL via Chris Lobdell

BOX 231 MERIN
ONTARIO
CANADA
M9P 1W5

We thank you for your reception report for our transmission on

SUNDAY 6TH DECEMBER 1952
ON 7415 KHZ. U.S.B.
05.29 - 05.52 UTC.
SIO 242
RELAYED BY WARI

\$1.00. v/s David E. Laufer, Public Relations. (Comeau-MA). same in 46 ds. for ms. (Fanderys-OH). cd. w/ ltr. and stickers in 12 ds. for rpt. to CA. Also rcvd. direct from site in 40 ds. v/s Ben Cabral. (Stephens-AL). cd. in 38 ds. for \$1.00. (Davis-NM) f/d "World Map" cd. in 20 ds. for a taped rpt. and 2 IRCs. (name?)
PAPUA NEW GUINEA: Radio Simbu 3355 n/d personal ltr. in 101 ds. for SASE. v/s Gabriel Palao, Station Technician. (Murray-OR). Radio Western 3305 p/d ltr. in 1 mo. for \$1.00 v/s G. Gedabing, Station Manager. (Kohlbrener-PA).

NEW GUINEA TERRITORY: Radio Western

Highlands 3375 f/d "NBC Map" cd. w/ ltr. in 5 wks. for \$1.00. v/s Esau Okole, Technician. (Kohlbrener-PA). f/d cd. w/ personal ltr. in 26 ds. for ms. (Stephens).

NEW ZEALAND: Radio New Zealand International 17770 f/d cd. w/ personal ltr. and stickers in 53 ds. (Jones).

NORWAY: Radio Norway International 11795 f/d cd. w/ sticker and schedule in 31 ds. (Bickus-VA).

PALAU: KUEN Voice of Asia 9830 f/d cd. in 25 ds. via the Calif. addr. for

in 25 ds. via the Calif. addr. for in 25 ds. for ms.

VERIFICATION SIGNERS: Radio Maya de Barillas

Jose Castaneda, Gerente. La Voz de Atitlan

2390 Juan Altzip Alvarado, Director. AIR

Port Blair 4760 B. Sekhar Reddy,

Assistant Station Engineer. AIR

Jaipur 3345 S.C. Sharma, Station

Engineer. RRI Jambi 4927 Marlis

Ramali. Radio Emisora Minería 4981

Jose Carlos Gomez Espinoza. Radio

San Miguel 4924 Jose Luis Aguirre

Alvis, Director. Radio Cultura Foz

de Iquacu 6105 Ennes Mendes da Roc-

ha, Gerente Geral. Radio Educacao

Rural Coari 5035 Elijane Martins

Correa. Radio Ribeirao Preto 3205

Segr. Miss Lucinda de Oliveira. Radio Brasil 4785 Wilson Roberto Correa Viana, Gerente. Addr: Av. Benjamin Constant 1214, Campinas 13013, SP. Radio Tupi 4975 Celso Rodrigues de Oliveira, Asesor Int. da Presidencia. Radio Marajoara 4955 Mrs. Neide Carvalho. Ondas del Ortoquaza 4978 Jorge Daniel Santos Calderon, Gerente. La Voz de Los Caras 4975 Eduardo Rodriguez Coll....via PLAY DX...Sam.

Reach me on my new line!

N5QRM



PARAGUAY: Radio Nacional 9735 p/d ltr. in 101 ds. for a SP rpt. and \$1.00. v/s Filemon G. Arguello M. (Lawrence).

PERU: Radio Satelite 6724.4 f/d "Certificado de Sintonia" w/ personal ltr. in 2 mo. for * a SP rpt. and \$1.00. Also rcvd. f/d prepared cd. v/s Sabino Llamo Chavez, Gerente. Station address has changed to Jr. Cutervo 543. (Clar-NY).

Name: Christopher Lobdell QSL
Date: Dec. 23, 92
Time: 13:09 to 1259 U.T.C.
Freq. 81715

Thanks you Mr. Lobdell
God Bless you
Michael Renteria mgr

King Jesus Spiritual Savior
80 KW - 500
The Lord's Ranch
Mesquite, NM 88048 U.S.A.

PHILIPPINES: FEBC 11690 f/d cd. w/ personal ltr. in 74 ds. for 1 IRC. v/s Jamie Reid, QSL Secretary. (Lawrence).

PORTUGAL: Radio Renascenca 9600 f/d "Antenna/Logo" cd. in 108 ds. for a PT rpt. (Stephens-AL).

ROMANIA: Radio Romania International 9510 f/d "Church of Voronet" cd. in 130 ds. (Schwartz-NY).

RUSSIA: Radio Aum Shinrikyo 15425 cd. in 26 ds. w/ schedule for \$1.00. (Davis) 12070 f/d cd. in 3 mo. (Barto-CT).

QSL
Verification Card

Station Sierra Leone Broadcasting Service
For Donald M. Hosmer

Thank you for your reception report. We are pleased to verify your reception of our transmission on 2 January 1992 from 06:05-07:28 hours
UTC on 3315 kHz. with a power of 10 kilowatts.



X 9 Special Assistant to the Director

Official Seal

ms. C/V #2181 (Sgrulletta-NY). cd. w/ ltr. in 2½ mo. (Forth-IL). f/d "25th Year" cd. in 75 ds. for \$1.00. (Gold-MT)...Thanks for the call on this one...Sam.

SATPAN: **KHBI** 13625 f/d cd. w/ tourist info. in 33 ds. for \$1.00. (Murray-OR). f/d "Transmitting Towers" cd. in 61 ds. for ms. (Newhall-CT). **KFBS** 11650 f/d cd. w/ schedule in 48 ds. v/s Doug Campbell, Field Director. (Helm-KS)

SAUDI ARABIA: **BSKSA** 15060 ltr. in 10 mo. for a taped rpt. v/s Sulaiman Saman, Director of Frequency Management. (Forth-IL)...I have always wondered about this station. With all the operating funds one would think the station has, why haven't they ever responded

VERIFICATION SIGNERS: **Radio Bangladesh** 4880 M.A. Haque Bhuiya Sr., Engineer in Charge. **Radio Clube Marilia** 3235 Antonio Carlos Nasser. **Radio Clube Varquinha** 3245 Juraci Viana. **Radio Santa Maria** 6029 Rocco Martinello Avila, Director Ejecutivo. **Radio Esperanza** 6088 Eleazar Jara, Jefe Depart. mo Programacion. **Honghe P.B.S.** 4931 Mrs. Cheng Lin, Reporter Editor / Shen Dechum, Head of Station. Addr: Jianshe Donglu 32, Gejiu City 661400, Yunnan. **Radio Venceremos** 6750 Anita Ocampo, Secretaria. **Voice of Mojahed** 6220 Babak Amani. Addr: M.I.S.S. BM Box 9270, London WC1N 3XX, England. **La One 103** 4800 Luis J. Rodriguez. Addr: Pedro F. co Bono' 58, Santiago. **Radio Nacional Progreso** Jose Guaman G. **Radio Bremen** 6190 Jim Senberg. **Sudwestfunk** 7265 Hans Krankl, Chief Engineer.....via PLAY DX...Sam.

to their listeners reports with more detailed OSL cds or with station pennants?...Sam.
SARAWAK: **Radio TV Malaysia** 4950 via **Kuching** f/d "Broadcasting House" cd. in 20 ds. for 2 IRCs. (Martin-CA). 5005 via **Sibu** same in 11 mo. for ms. This after 2 f/up rpts. (Kohl-SEYCHELLES: **BIC** 11730 f/d ltr. in 39 ds. v/s Peter Lee, Resident Engineer. brenner-PA) (Nibecker-MEX). **FEBA** 11710 f/d cd. in 3 mo. for 1 IRC. v/s Mary Asba, OSL Secretary.
SICILY: **RAI Caltanissetta** 7175 n/d cd. in 109 ds. for a taped rpt. (Klinck) (Pankake-MN).

SIERRA LEONE: SLBS 3315 f/d prepared cd. in 11 mo. for a taped rpt. and SASE. Very pleased w/ this one! Freq. is correct as the station was 1 kHz. off on 1/2/92. (Hosmer-MI)...Don, sometimes my wife says I'm a few kHz short of a mHz...Sam.

SINGAPORE: Singapore Broadcasting Corp. 5052 f/d cd. w/ personal ltr. and stickers in 22 ds. for 1 IRC. v/s Lee Wai Meng. (Martin-CA). 11940 f/d cd. w/ personal ltr. and promo cds. in 19 ds. after 2 rpts. to the station. (Stephens-AL).

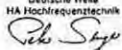

Wir danken Ihnen für Ihren Empfangsbericht und bestätigen Ihnen gern die Richtigkeit Ihrer Beobachtung. Sie hörten unseren Sender MALTA am: 1.12.1989 um: 0128 UTC auf 11865 kHz Thank you for your reception report which has been checked with our schedules and found to be correct. We are very glad to verify here with your report. Deutsche Welle HA Hochfrequenztechnik 	DRUCKSACHE - IMPRIME John Spencer Carson, Jr. Norman, OK 73071 USA
---	---

SINGAPORE: BBC 15360 via Kranji f/d cd. in 18 ds. (Yamada-JPN).

SOUTH AFRICA: ZSC Time Station 17018 f/d "Table Mountain at Capetown" cd. w/ schedule and schedule in 253 ds. v/s Gary Carter, Control Coastal Radio Officer. (Fanderys-OH). Radio Orion 4810 f/d "DJ Robin Alexander" cd. w/ personal note in 34 ds. for 2 IRCs. v/s Kathy Otto. (Brouillette-IL). f/d cd. in 6 wks. for \$1.00. Schedule was rcvd. (Kohlrenner-PA). same in 6 wks. (Craighead-KS).

SPAIN: Radio Exterior de Espana 9530 f/d cd. w/ schedule in 85 ds. for 1 IRC. (Pankake-MN).

SUDAN: Radio Omdurman 9170 f/d ltr. in 27 ds. for 2 IRCs. v/s Mohamed E. Khalil. (Comeau).

* National Broadcasting Corporation of Sudan 7200 p/d ltr. in 92 ds. for a taped rpt.

SULAWESI: RPDT2 Buol-Tolitoli 3654.2 f/d prepared cd. w/ p/d personal ltr. (Klinck-NY).

* in 27 ds. after 3 f/up rpts. in IN. SASE was sent and used. v/s Said Rasjid. (Palmer-SUMATERA: RRI Pekanbaru 5984.2 p/d ltr. in 15 ds. for an IN rpt. and 1 sheim-WA).

IRC. (returned). Arrived via registered mail. v/s Drs. Mukidi, Kepala. (Yamada-JPN).

TAHITI: RFO 15172 f/d cd. in 44 ds. for a FR rpt. and \$1.00. (Helm-KS). 15175.6 p/d cd.

in 45 ds. for 2 IRCs. v/s Leon Siguin, Cadre Superieur Technique. (Brouillette-IL).

TAIWAN: Voice of Free China f/d cd. w/ stickers and schedule and a personal ltr. in 119 ds. Also rcvd. a frisbee "flying saucer". (Jones-OH).

TIMOR (Portuguese): RRI Dili 3306 p/d cd. in 6 wks. for an IN rpt. and ms. v/s Harry A.

* Silalahi. (Kohlrenner-PA).

TONGA: A3Z Tonga Broadcasting Commission 5030 p/d "Coat of Arms" cd. in 26 ds. after 2 f/up rpts. for a 1991 reception. (Lare).

UKRAINE: Radio Ukraine International

17690 f/d cd. in 49 ds. w/ schedule. (Bickus-VA).

USA: WJCR 7490 f/d cd. in 32 ds. for ms.

v/s Gerri Powell. (Hardester-NC). f/d cd.

w/ form ltr. in 17 ds. v/s Don Powell, President. (Davis-NM). f/d cd.

w/ sticker and ltr. in 10 ds. (Stephens-AL). KVOH 17775 f/d "World Map"

cd. w/ schedule and a personal note

in 11 ds. v/s Patrick C. Kowalick. (Stephens). KJES 11715 f/d cd. in 3 wks. v/s Michael

Rentler, Manager. (Humenyk-ONT). f/d cd. w/ personal note in 1 wk. for \$1.00. and ms.

v/s Michael Geuter, Manager. (Name?) cd. in 10 ds. for ms. (Lobdell). f/d cd. in 3 wks.

for SASE. (Sgrulletta-NY). f/d cd. in 20 ds. for \$1.00. (Comeau-MA). same in 15 ds. for

\$1.00. (Buer-FL). 11790 f/d cd. in 17 ds. (Helm-KS). 9510 cd. in 19 ds. (D'Angelo-PA).

Voice of the OAS 9565 f/d cd. in 30 ds. for a SP rpt. (Helm-KS). WRNO 15420 f/d cd. in

50 ds. (Bickus-VA). WSMN 4770 (2 x 1590) p/d ltr. in 10 ds. v/s Larry L. Beavers, Engineer.

(Washburn-ME). WJNB 15295 f/d cd. in 20 ds. for \$1.00. (Comeau-MA). KGEI

15280 f/d "Golden Gate Bridge" cd. in 34 ds. for \$1.00. v/s Jesus C.

Elizondo. (Comeau-MA). WHRI 9495 f/d "Globe" cd. w/ schedule in 2 mo. for

ms. (Carter-WA). Radio Bosnia-Herzegovina 7315 via WHRI QSL ltr. rcvd.

requesting contributions in 1 mo. for \$1.00. Addr: Bosnian-Canadian Relief

Association, 4174 Dundas Street West, U. 290, Etobicoke, Ontario M8X 1X3,

Canada. (Craighead-KS). KYBN 15590 f/d "Antenna Array" cd. in 2 mo. for ms.

(Carter-WA). WFLA 25870 p/d cd. in 8 ds. for SASE. v/s Wilson Welch, C.E.

100 watts! (Sgrulletta-NY).

BBC EAST ASIA RELAY COMPANY LIMITED

Tung Tau Broadcasting Station, Ben Wan, Yuen Long, New Territories, Hong Kong
 Tel. 072044-072043. Telex: 31196 BRC11 HK Fax: 0-4746003

9th Jan., 1990

Michael S. Hardester
 HOCO, HQDR - DAS
 JRD HARDIV - FHF
 PPO SAN FRANCISCO, CA/ 06602-8602
 U.S.A.

Dear Mr. Hardester,

Many thanks for your letter dated 10th December with the details of the reception report.

Unfortunately, we no longer send out QSL cards and we would normally not acknowledge receipt of reception reports. However in this instance it is nice to know that we coming in loud and clear on 21715 MHz in Japan.

Enclosed is a list of times and frequencies broadcasted by the BBC. This information is available from our monthly magazine London Calling available on subscription from:-

That's about it for this month. We will get in the remaining reports in the next QSL Column....Sam.

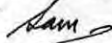

NASWA Scoreboard

Jerry Lineback
6361 Shore Drive
Douglasville, GA 30135



Greetings to all NASWA Associates. Welcome to the March NASWA SCOREBOARD. The SPOTLIGHT this month is on South America. Please note that CH=Countries Heard and CV=Countries Verified. Country counts are according to the latest NASWA Radio Country List. Next Deadline for the SCOREBOARD will be May 15 for the June Issue of the Journal. The SPOTLIGHT will be on Africa.

Name, State	Total C/H	C/V	SA C/H	SA C/V	Best SA QSL
James Young, CA	240	225			
Gordon Darling, P/NG	236	230	15	15	Falklands
Jerry Berg, MA	230	229	15	15	R. Mamore, Bol.
Marlin Field, MI	230	228	15	15	R. Apinte 4794
William Flynn, OR	228	211	15	15	Falkland Is.
Gerald Bishop, FL	225	211	15	14	FIBS
Ed Shaw, KY	225	208	13	13	Pto. Martinez
Mitch Sams, MO	224	187	15	15	"Liberty"
Steven Lare, MI	223	195	15	13	Flaklands
Nobuaki Takahashi, Japan	223	194	15	10	R Pres Prudente
Donald Hosmer, MI	219	189	15	13	FIBS
John Sgrulletta, NY	218	218	15	15	Falkland 2380
Al Miller, Jr., OH	217	209	15	15	Galapagos
Richard Davis, NM	212	201	15	15	Falkland Is.
Paul Buer, FL	211	198	14	14	R. Apintie
Ron Howard, CA	211	194	15	15	R. Patagonia Ch
Sheryl Paszkiewicz, WI	210	203	15	15	Falklands
Kirk Allen, OK	209	200	15	15	Rdif. Huanta
Rick Krzemien, CA	209	196	15	12	Galapagos
Christos Rigas, IL	206	186	15	15	Falkland Is.
Frank Orcutt, NY	206	175	15	12	R. Demerara
Jerry Lineback, GA	206	108	15	12	Maranhao
Dino Bloisse, Dominican Rep.	205	75	15	15	Ecos del Torbes
Mike Hardester, NC	203	190	15	14	Falklands
Fred Kohlbrenner, PA	203	173	14	14	Galapagos
Robert Ross, Ont.	200	178	14	13	R Moderna, Peru
Jerry Klinck, NY	197	170	12	10	LV de Chile 10k
Charlie Washburn, ME	192	146	13	8	R. Demerara
Larry Kramer, CO	188	120			
Walter Kunz, PA	183	108	15	6	Surinam
Ichiro Maruo, Japan	174	113	11	6	R. Illimani
Rev. John Eckert, PA	173	156	12	11	R. Panamericana
Jim Renfrew, NY	171	136	14	12	BFBFS Falklands
Allan R. Loudell, DE	169	136	12	10	R. SRS
Andy Rugg, Que.	167	151	12	11	CP73 Bolivia
Nick Grace, DC	157	114	11	9	Ondas del Mayo
Daniel Prisco, CA	156	133	14	13	Galapagos
Carl Radtke, WA	153	153	12	12	Quillabamba
Stephen Price, PA	153	118	10	7	RFO Fr. Guiana
Thomas Ross, IL	152	131	10	9	HCJB 100W
Bill Taylor, PA	152	115	12	8	HCJB 26020
Mark Humenyk, Ont.	152	106	12	7	ECJB
David Morby, NY	149	42	12	3	Radiobras
Ross Comeau, MA	146	99	11	6	Guyana GBC
Richard Hankison, KS	142	113	11	8	R. Ancash
Richard Wallace, CT	137	85	8	5	R. Continental
Bill Kurrasch, NY	133	97			
Scott Helm, KS	133	82	11	4	RAE Argentina
Elliot Straus, NJ	123	63	11	05	GBS 3290
Barry Schwartz, NY	118	91	10	5	Caracol, Col.

Name, State	Total C/H	C/V	SA C/H	SA C/V	Best SA	QSL
Jerry Ervine, TX	115	65				
Jason Moore, KY	113	62	10	5	YVTO	
David Galletly, NY	110	88	7	5	YVTO	
Robert Carlsen, OH	110	87	10	5		
Mark Spat, NH	108	26				
Bruce Orenstein, NY	100	68	7	2	Brazil	
Lowell Pankake, MN	99	13	9	1	HCJB	
Kevin Murray, OR	98	77	6	5	LOL Argentina	
Brian Boulden, CA	97	85	9	6	YVTO	
Royal Berglee, ND	81	51	6	3	R. Bras	
Andreas Scheurell, PA	80	27	8	1	HCJB	
Mark Anderson, MI	65	54	6	3	R. Rumbos	

Thanks to all who contributed this quarter. You must update once a year to remain listed on the SCOREBOARD. When updating, please update all totals. Remember the next deadline is May 15 and the SPOTLIGHT will be on Africa. 73s,

WANTED: Old SWL receivers such as Hallicrafters, Scott, and Zenith. C. Blatter, 610 West Sunset Drive, Redlands, CA 92373-7240.

FOR SALE: JRC NRD-525/535 Extender Service Boards or the correct connections to build yourself. \$75.00 for the board or \$16.00 for a set of connectors. **FOR SALE:** Grundig Satellite 5000 (1967). Has LW/MW/FM/SW1-4 (1.6-30 MHz) plus separate drum bands for 16, 19, 25, 31, 41, and 49 meter bands. Optional BFO, ANL and MGC/AGC board. Switchable 110/220 VAC in - 7.5/9 VDC out power supply. Could use new antenna, but works great. With service manual. Best offer. Terry Palmersheim, 1413 West James Court #L-8, Kent, WA 98032-4357. Phone home (206) 850-2088 from 0000-0800, work (206) 251-0700 ext 20 from 1400-0000. Both times UTC.

FOR SALE: JRC NRD-525 receiver. No modifications. In excellent condition with original carton and manuals. \$700.00 including shipping. Andrew Herrschaft, 28 Leonard Street, Portland, ME 04103. Phone (207) 773-1562 evenings.

FOR SALE: Drake R7 with 6, 4, 3, 2.3, and 1.8 filters, NB7A, Aux7, R4245 knobs. Drake aligned 10/91, \$1075.00. MS7 speaker, \$60.00. MN75 antenna tuner, \$150.00. Drake R8 just serviced by Drake with all current circuit mods, \$775.00. Drake R-48 in excellent condition with crystals for all major SWBC bands, \$225.00. Eavesdropper-C trap dipole, new and never used, \$60.00. 10:1 matching transformers for matching long-wire and Beverage antennas as reviewed in July Journal, now with brass terminals to avoid the rust problem as described by Alan N4LUS, \$20.00 each postpaid in the U.S.A. Steven R. Lare, 824 West 25th St., Holland, MI 49423. Phone (616) 335-2270.

FOR SALE/TRADE: WRTVH-1979, Wave Prop (1957), Heath Manual HD-10 Electronic Keyer. All \$13.50 or trade for \$2.00 and 1992 "Passport to Worldband Radio". Tom Mooningham, P.O. Box 487, Maugansville, MD 21767.

FOR SALE: Sony ICF-2010 receiver. Has all the goodies. New 9/92. Will sell for \$250.00 plus shipping. Jack Murphy, 201 West Glencove Ave., Northfield, NJ 08225. Phone (609) 641-3189.

WANTED: Eddystone 1830. Bill McCarthy, 591 Rue Beausoleil, Dieppe, New Brunswick, Canada E1A 1C3.

FOR SALE: Yaesu FRG-7 with GAR-7 Gilfer digital readout. Top of one digit missing, but otherwise works good. Best offer. Also Kenwood R-2000. Best offer over \$350.00. Also ADR-1000. Recently factory aligned. Best offer. I would also like to exchange TV and SWBC ID's. Send SASE for more information. Jerry M. Stuart, Box 2652, Lawton, OK 73502.

Contributors' Page

Vernon Hyson
5410 Camp Stewart Road
Charlotte, NC 28215
CompuServe 76516,1531



LOGGINGS CONTRIBUTORS - MARCH 1993 - DEADLINE 10th of MONTH

The following members contributed loggings:

Brian ALEXANDER, Mechanicsburg, PA	NRD525 various Longwires
Mark ANDERSON, Prescott, MI	DX440 40' Random
Guy ATKINS, Bonney Lake, WA	R8 R390A Satellite 90m T2FD Mini-Beverage
Jerry BERG, Lexington, MA	R8 HQ180A R390A 150' Longwire
Juhanna BICKUS, Herndon, VA	ATS803A Transoceanic
Michael BILEC, Port Vue, PA	DX380 Portable Antenna
Dino BLOISSE, Jersey City, NJ	R5000 Sony 2010 MFJ959 80' LW
John CARSON, Norman, OK	NRD525 NC183D Sony 2010 AD Sloper 500' Bev
Jim CLAR, Rochester, NY	R8 FRG8800 ATS803A Eavesdropper 110' LW
David CLARK, Newmarket, ONT	R8 2-R7 HQ180C R8 Many, many antenni
Richard D'ANGELO, Wyomissing, PA	R8 AD Sloper Farley Loop
William DAVENPORT, Nashville, TN	DX330 ICF7601 AN-1
Ardie DURDEN, Albany, GA	NRD515 SE3 Inverted V
Shawn FAHRER, Howard Beach, NY	MT798A
Marlin FIELD, Hillsdale, MI	NRD535D SPR4 Eavesdropper
David FRENZ, Milwaukee, WI	R8 31m/66' dipoles, 101' LW
Harold FRODGE, Midland, MI	R71A DX302 AP4 Trap Dipole 185'/100' Random
Michael HARDESTER, Jacksonville, NC	R70 Sony 2010 25' Random RWest Loop
Rufus JORDAN, Pittsburg, PA	DX302 Transoceanic 33' LW
W. KARCHESKI, Holden, MA	R5000 AD Sloper
Jerry KLINCK, West Seneca, NY	R8 HQ180A Sony 2010 350' Mini Bev 80' LW
Marie LAMB, Brewerton, NY	R600 MFJ16010 20m/90m LW
Harold LEVISON, Philadelphia, PA	R8 R70 D2999 Indoor LW
Kevin MURRAY, West Linn, OR	R8 Eavesdropper
Ed. NEWBURY, Gordon, NE	R8 R5000 70' Windom 66' Dipole 45' Segmented
Marina PAPPAS, Huron, SD	
Doug ROBERTSON, Oxnard, CA	DX302 FRG8800 FRA7700 ATS808 Longwire
Elliot STRAUS, Toms River, NJ	R390A 70' LWx2
Robert TUCKER, Savannah, GA	ATS803A
George VADINO, Bellevue, WA	
Dave VALKO, Dunlo, PA	NRD525
Andrew WALLACE, Lowell, MA	R71A 40' Indoor
Mike WOLFSON, Ashland, OH	NRD535 Sony 2010 125' Longwire
Juichi YAMADA, Nara, JAPAN	NRD525 10m long Dipole

The cold finally hit the DXpeditioners - none this month. Dino Bloisse reported in from Santiago, Dominican Republic with his loggings.

Because of the earlier than usual deadline this month, contributors to the Tropical Band Section are not listed. Fear not, good listeners, we'll list all of you next month!

Enjoyable listening & good DX -

Tropical Band Loggings

Sheryl Paszkiewicz
1015 Green Street
Manitowoc, WI 54220



- 2310 AUSTRALIA VL8A 1/23 1158 show tunes //2325, 2485 (Valko-PA)
 2325 AUSTRALIA VL8T 1/23 1009 crooners, 1030 nx, pops (Orr-VA)
 2390 GUATEMALA LV de Atitlan 1/9 0200 ballads, ID (Valko-PA)
 1/26 0301 marimbas, few vcIs, IDs, closing 0328 (Frodge-MI)
 2410 NEW GUINEA R Enga 1/23 1155 sing-sing, weak (Clark-ON)
 3200 SWAZILAND TWR 1/6 0320 gospel songs, M lang (Newbury-NE)
 3200.4 BOLIVIA R 9 de Abril 1/23 2320 vcIs & ID (Johnson-GP)
 1/23 2321 ad, flute, echo ID, OCR medley (Valko-PA)
 1/28 2335 fair w/tlk by YL, seems irregular (Clark-ON)
 3222 TOGO R Kara 1/11 to 2305* FR nx (Doherty-MA) 2/7 0530
 song, ID, rel mx (Frenz-WI)
 3222.9 SUNDAS Mataram 1/10 SCI, 2200 nx, anthem, YL (Clark-ON)
 3230 SOUTH AFRICA R Orion 1/13 0350 mx, EG nx (Doherty-MA)
 3231.9 SUMATRA Bukittinggi 2/5 1453 chant, ID, SCI, nx (Murray-OR)
 3235 NEW BRITAIN RWNB 1/22 0831 G&W, pops, TP, nx //3345 (Orr-VA)
 1/23 1253 vcIs, closing, ID, TC, freq (Valko-PA)
 3250 HONDURAS Luz y Vida to 0356* & 1148 LA pops, horses, ID
 Folk mx (Clar, Davenport, Frenz, Jordan, Alexander, Valko)
 3255 INDIA Shillong 1/24 1603 big band mx, EG YL (Atkins-WA)
 3255 LESOTHO BBC 2/7 0350 nx, mail (Anderson-MI) 2/14 0406
 nx, fair (Laves-TX)
 3259.7 SUNDAS Kupang 1/5 1645 pops, ID, IS, nx, NA (Yamada-JAPAN)
 3264.8 SUMATRA Bengkulu 1/4, 1447 mx, IS, nx, trad mx (Yamada)
 1/28 2308 nx //3231.9, 4925, anthem (Clark-ON)
 3266.4 SULAWESI Gorontalo 1/24 1242 drama, ID, nx (Yamada-JAPAN)
 3277 KASHMIR RK 2/8 0113 threshold audio, SC mx (Clark-ON)
 3279.8 ECUADOR LV del Napo 0205-0305*, 1206 nx, ads, IDs, folk
 mx, Battle Hymn of Republic (Clar, D'Angelo, Davenport,
 Alexander, Field-MI)
 3280 CHINA Vo Fujiang 1/25 1220 CH tlk, instl //7115 (Orr-VA)
 1/30 1245 class mx, tlk //4950, not 3990 (Clark-ON)
 3290 NAHIBIA NBC 1/26 0431 nx, remotes, ID, wx (Lamb-NY) 1/11
 2149 EG phone ins, mx (Doherty-MA)
 3290 PAPUA R Central 1/22 0910 nx & prov. nx in EG (Valko-PA)
 3300 GUATEMALA R Cultural 1/7 0330 EG Back to the Bible (Davenport)
 3306.4 TIMOR Dili 2/7 1245 noted here ex-3306.05 (Clark-ON)
 3315 INDIA Bhopal 1/24 1532 EG nx //3375 (Atkins-WA)
 3316 SIERRA LEONE SLBS 0810, 2317* nx, ID, tlk abt Allah,
 lottery, meditation (Valko, Wolfson, Bergadano, Doherty, Orr)
 3324.9 KALIMANTAN Palangkaraya 1/25 to 1455* EG lesson (Yamada)
 1/12 2159 SCI, nx, anthem, lcl ID, instl 50 kW? (Clark-ON)
 3326 NIGERIA R Nigeria 1/31 2203 Wynonna Judd (Bergadano-NJ)
 2/7 2235 EG on the line pgm (Doherty-MA)
 3329.8 PHILIPPINES FEBC 1/14 2103 Filipino, MA, mx (Yamada-JAPAN)
 3335 SWAZILAND TWR 2/15 0350* rel mx, ID, IS (Laves-TX)
 3335 TAIWAN CBS Taipei 1/31 2135 OM tlk, nx, fanfare (Clark-ON)
 3339.9 PERU Altura 1/24 0040 huaynos, ID, tnx Valko (Johnson-GP)
 2/3 1108 OA mx, no ID so tent (Field-MI)
 3345 MOLUCCAS Ternate 1/24 1358* pops, Love Ambon (Yamada-JAPAN)
 1/31 pres at 2132 IN tlks, prob. nx (Clark-ON)
 3345 PAPUA R Northern 0900-1235 nx //others, educ. pgm, lcl
 mx, OM anmmts (Orr, Valko, Klinck)
 3350.3 ECUADOR R Cumanda 1/29 1020 mx, echo IDs, no ads (Johnson-MD)
 3355 NEW GUINEA Simbu 2/6 1251 strong w/Ray Charles, TC, anmts,
 anthem, AIR Kurseong fair after s/off (Clark-ON)
 3356 BOTSWANA RB 2/3 0329 pops & reg mx (Frenz-WI) 2/14 pres.
 at 0413 prayers in EG, //4830 (Laves-TX)
 3365 CUBA Rebelde 1/7 0340 //5025 mx, ID, TC (Davenport-TN)
 1/20 1003 nx items, little mx (Levison-PA)
 3366 GHANA GBC 2/5 2245 in EG (Doherty-MA)

- 3370t BOLIVIA R Florida 1/23 2330 strong sig, weak audio, def.
SP & LA mx (Valko-PA)
- 3370 GUATEMALA R Tezulutlan 1/17 0406* IDs, marimba (Alexander)
- 3375 BRAZIL RN Sao Gabriel 0918 IDs, ballads, TC, ads, accordion
mx, EBIBRATEL nx (Orr, Valko, Lawrence, Durden)
- 3375 BRAZIL R Educadora 1/23 1000 campo mx, ID, TC (Orr-VA)
- 3375 INDIA Guwahati 1/9 1228 vcl, tlk not //4860 (Clark-ON)
1/24 1530 EG nx, ID (Atkins-WA)
- 3375.5 SUMATRA Medan 1/22 2150 Koran, IS, nx (Yamada-JAPAN)
1/12 2259 SCI, nx unreadable (Clark-ON)
- 3380 GUATEMALA Chortis 1/29 0220 IDs, marimbas, TCs (Clar-NY)
1/30 0318 vcls, some anmts, fair (Levison-PA) to 0400* &
1240 Musica de Hoy pgm (Lamb, Bergadano, Yamada)
- 3380.7 HAWAII NBC 1/17 0352 sermon in EG (Clark-ON) 1/22 2200
Dueling Banjos, ID, TC, nx (Valko-PA) 1/9 2205 organ mx
EG ID, anthem to 2211* (Clark-ON)
- 3384.9 SUNDAS Kupang pres 1/22 1247 tlk, mx, nx, Love Ambon (Valko)
1/23 1308 Jak nx, anthem, lcl mx (Clark-ON)
- 3385 NEW BRITAIN RENB 1/20 1237 EG ID, lcl mx (Klinck-NY)
- 3395 NEW GUINEA R East. Highlands 1/23 1235 island mx, YL
(Lawrence-NY) 1/20 1237 lcl mx, anmts in lang (Klinck-NY)
- 3395 SUMATRA Tanjungkarang 2/10 2244 choral, SCI, nx (Orr-VA)
- 3402.5h PERU RN Peru 1/22 0938 flutes, ID, TC 4x850 (Valko-PA)
1/20 1030 huaynos, "R Internacional" (Johnson-MD)
- 3664.5p AZAD KASHMIR AKR 1/24 1303 threshold audio (Clark-ON)
- 3904.8 SUMATRA Banda Aceh 1/12 2311 strong, lcl pgm, chime IS (Clark)
- 3925 JAPAN R Tampa 1/12 1325 JP pgm, hvy QRM (Newbury-NE)
- 3935 NEW ZEALAND ZLXA 1/27 0800 ID, nx, mx bridge (Clark-ON)
- 3940 UNID REE 0100-0300 unsure if Spain or Costa Rica relay,
IDs, mx, TC, IS, phone calls (Levison, Clar, Davenport)
- 3945 INDIA Gorakhpur 1/1 *1344 Hindi IS, mx, tlk (Yamada-JAPAN)
1/24 1539 EG nx, ID //3375 tnx Schulze (Atkins-WA)
- 3945p SUMATRA Tanjungkarang 1/4 1600 nx, NA, pops (Yamada-JAPAN)
- 3945 VANUATU RV 1/15 1841 in lang, lcl mx, NA, nx (Yamada-JAPAN)
- 3955 ENGLAND BBC 1/23 0500 EG nx abt Clinton (Bilec-PA)
- 3960 GERMANY RFE 1/13 0501 tlk in lang (Field-MI)
- 3970 CAMEROON CRTV Buea 1/17 2135FR tlk, sig worse after 2200
my 1st log of this (Field-MI)
- 3980 GERMANY VOA 1/5 0530 EG nx (Bilec-PA) 1/1 1925 Newsline,
Magazine Show (Yamada-JAPAN)
- 3985 SWITZERLAND SRI 1/22 0500 EG IS, ID, Dateline (Davenport)
- 3987.2 IRIAN JAYA Manokwari 1/23 1239 EZL, Jak nx (Clark-ON)
- 3995 GERMANY DW 1/22 2010 GM tlk, class mx, IDs (Davenport-TN)
- 3995 KALIMANTAN Pontianek 2/1 1128 IS, nx, NA, mideast pops,
SCI, Jak relay, ID tnx Clark/Berg (Valko-PA) 1/27 1300
nx, IDs, tlk show (Clark-ON) 1/24 to 1605* lcl ID, SCI,
Jak nx, "dari Pontianek," tnx Clark (Atkins-WA)
- 4000 CAMEROON Bafoussam 1/30 2140 FR, ID to 2204* (Bergadano-NJ)
- 4003.2 SUMATRA Padang 1/22 2210 Koran, tlks (Yamada-JAPAN)
- 4012.1 PERU Frecuencia Pop, 1/23 1040 huaynos, TCs, ID, TC 6 min.
slow! nx (Valko-PA)
- 4450 BOLIVIA R Frontera 0928 ballads, ID, BBC SP pgm, ads for
auction, Lennon (Orr, Durden, Valko, Field-MI)
- 4472 BOLIVIA Movima 2/6 1024 mx, ID, ute QRM, new for me (Forth-IL)
- 4485 PERU LV de Celendin 1/22 0339 mx, echo ID 0357 (Johnson-MD)
- 4505 PERU Horizonte 1/9 1118 flutes, echo ID by M (Forth-IL)
- 4552.4 BOLIVIA Ref. Tropic 1/22 1010 echo anmts, IDs (Orr-VA)
1/14 pres. 1040 mostly mx to 1059 fade (Field-MI)
- 4561.5 COLOMBIA unid 1/10 1034 TC, ID "Ondas?" ment Colombia (Valko)
- 4599.8 UNID Villamontes? 1/21 1024 mx, rooster (Field-MI)
- 4605.1 IRAC R Baghdad 1/23 to 0038* & *0252 Hideast mx, bird IS,
NA, Koran, bubble jammer (Alexander-PA) 1/9 2110 AR tlk,
jammer, drama past 2200 (Clark-ON)
- 4606.3 IRIAN JAYA Serui 1/19 0910 Islam mx, Koran (Yamada-JAPAN)
- 4649 BOLIVIA Santa Ana 1/24 0013 long tlk, ID, anmts (Valko-PA)
2/1 2343 ID, CP mx, weak (Durdan-GA)

- 4657y VIETNAM Son La BS 1/30 vy poor 1211 & drifting. Next day way up on 4678.9 1215 hill tribe chants, tlk (Clark-ON)
- 4681.9 BOLIVIA R Paititi 1/11 1035 devotional, ID, weak (Durden-GA)
- 4697.1p JAVA Surabaya 1/20 1300 nx, NA, lcl mx (Yamada-JAPAN)
- 4704.6t PERU Estacion Laser 2/9 1039 huaynos, tlk, fades (Orr-VA)
- 4712.4 BOLIVIA Abaroa 2/9 1009 ballads, ID, TCs (Orr-VA)
- 4735 CHINA Xinjiang 2/8 1153 Uighur pgm, weak (Bergadano-NJ)
- 4747 PERU Huanta 2000 1/25 *1042 NA, amnts, pops, ID, ads (Orr-VA)
- 4753.4 SULAWESI Ujung Pandang 1225, 2230 ID, nx, tlk (Straus, Valko, Yamada, Clark)
- 4760 ANDAMAN Port Blair 1/31 1222 well over Kunming SC mx, ID then Leh could be hrd also above Kunming, nx, lcl pgm (Clark) 2/2 1249 EG, poor (Klinck-NY)
- 4765 CONGO RTV 1/1 0150 //5985 FR hilife, IDs, mx req (Clar-NY) 1/6 2145 M w/weak audio (Davenport-TN)
- 4770y ECUADOR Centinela del Sur 1/3 0027, 1100 nx, IDs, sfx, lecture, ads (Clar, Jordan, Lawrence) Clar also hrd this last month--sp.
- 4770 NIGERIA R Nigeria 0430-0624 talking drum, prayer, mx, nx, Nigeria Airways ad (Bilec, Newbury, Klinck, Doherty, Robertson, Bergadano)
- 4775p SIKKIM AIR Gangtok 2/9 0030 Hindi nx //4920, EG nx, Himalayan chants, YL intros (Clark-ON)
- 4775 PERU Tarma 2/6 1043 enjoyable vcls, ID, good (Forth-IL)
- 4780 DJIBOUTI RTVD *0258-0335 NA, amnts, Koran, 0329 ID, nx (Valko, Clark, Durden, Lawrence)
- 4780 UNID 1/29 1225 AR tlk, mx, help? (Klinck-NY)
- 4782.4 MALI RTV Maliene 2/5 0554 guitar IS, NA, ID, nx (Frenz-WI)
- 4785 CHINA Zhejiang 1/10 2200 in CH (Doherty-MA)
- *4786.8y SOUTH VIETNAM Gia Lai BS, Playcu 1/31 1140 hill tribe chants, tlk, drifting, close 1200*, same time noted by Foster in OZDX. 2/7 1140-1200* other Viets well hrd. 1/28 2252 amnts, march mx, 2300 nx (Clark-ON) 1/16 tent at 2257 ment Vietnam, tnx Valko, Playcu is new spelling (Johnson-MD)
- 4789 IRIAN JAYA Fak-Fak 1200 tent w/EG lesson, Indopops (Davenport-TN) 1/20 1252 pops, IS, nx, NA (Yamada-JAPAN)
- 4790 PERU R Atlantida 1/12 0955 rooster, IDs (Frenz-WI)
- 4795t BRAZIL R Aquidauana 2/8 0800 instl, ment Sao Paulo (Straus)
- 4795t CAMERCON ORTV Douala 1/6 2251 tent ID, ute QRM (Davenport)
- 4795.3 ECUADOR LV de los Caras 1/21 0011 nx, ads, IDs (Clar-NY)
- 4800 ECUADOR R Popular 2/7 0450 ID, mx (Hart-MN)
- 4800 GUATEMALA R Buenas Nuevas 1/11 0115 ads, IDs, rel pgm (Davenport-TN) 1/23 1210 nx, Strauss march (Newbury-NE) 2/8 1215 clear ID, rel (Straus-NJ)
- 4800 LESOTHO RL 0350-0410, 1616 tribal drum, ads, kids choir, Steve Winwood, rap, class, hymns, ID (Davenport, Murray, Clar, Frodge, Atkins)
- 4805 BRAZIL Rdf Amazonas 1/23 0147 ID to 0200* (Klinck-NY)
- 4805.4 SUNDAS Kupang 1/30 1243 //3384.9 w/EZL (Clark-ON)
- 4810 PERU San Martin 1/22 0803 wild huaynos, ID (Orr-VA)
- 4810 SOUTH AFRICA Orion/Channel Afr. 0128, 2335 ID, Elton John, Beach Boys, cigarette ad (Newbury, Karcheski, Davenport, Frodge)
- 4820 ECUADOR Paz y Bien 2/2 0847 instl, IDs, flute (Orr-VA)
- 4820 HONDURAS HRVC 1/23 1225 rel, call in, gospel (Newbury-NE)
- 4820.9 PERU Atahualpa 2/4 0130 folk mx, ID, 2001 mx (Jordan-PA) 1/23 0921 campo mx, rapid-fire amnts, ID (Valko-PA)
- 4825 GUATEMALA R Mam 1/10 1135 kids vcl, ID (Lawrence-NY)
- 4825 UKRAINE RU 2/9 0120 EG IDs, bells, Uk. Diary (Straus-NJ) 1/31 0610 lang, instls, IS //7240 (Alexander-PA)
- 4830 BOTSWANA RB 1/22 0302 Bible, Afr vcls //7255 (Lawrence-NY)
- 4830 THAILAND RT 2/5 1359 EG amnt, JP nx, IS (Murray-OR)
- 4830 VENEZUELA Tachira 1/22 2350 marimba, ID, het (Newbury-NE)
- 4835 GUATEMALA Tezulutlan 0205, 1240 rel, IDs, marimbas, prayer (Straus, Bickus, Davenport, Newbury, Clar)
- 4835t MALI RTV 1/30 2219 mx, nx, interview, ment Bamako (Frodge-MI)

- 4840p ECUADOR Interoceanica 1/5 1010 NA, mx, Valera QRM (Berg-MA)
 4840 PERU Andahuaylas 1/3 0948 ID, vcls, Valera QRM (D'Angelo-PA)
 4840 VENEZUELA Valera 1/25 0340 pops, IDs, NA (Lawrence-NY)
 2/1 0935 mx, ment SAM ctries, ID (Field-MI)
 4845 MAURITANIA ORTM 0007, 2310 call in, Koran, AR ID, mx, ment
 Mauritania (Levison, Karcheski, Newbury, Laves, Davenport,
 Frodge)
 4850 INDIA Kohima 2/7 1232 Hindi nx, SC mx u/Tashkent (Clark-ON)
 1/15 1245 EG ID, Hindi mx, no //s hrd (Klinck-NY)
 4855.7 PERU R La Hora 2/4 1023 huaynos, ads, TC, IDs (Crr-VA)
 4855.9 SUMATRA Palembang 1/28 2245 domestic mx, tlks (Clark-ON)
 4860 CIS RWS 1/6 2221 EG nx, weak, gone by 2240 (Davenport-TN)
 4860t INDIA Delhi 1/7 1250 cmtry, mx. Now have a digital rx
 (Davenport-TN) 1/31 1256 poss. Hindi tlk, static 5 times
 louder than YL (it figures) (Bergadano-NJ)
 4863.8 MOLUCCAS Ambon 2134 YL nx, Jak anthem (Clark-ON)
 4865 COLOMBIA LV del Cinaruco 1/12 0201, 1032 ads, ID, salsa,
 steel drums, etc (Davenport, Newbury, Levison)
 4866.5 IRIAN JAYA Wamena 1/23 1345 native vcls, weak (Clark-ON)
 4870 BENIN ORTB 0607, 2310* rom. mx, ment Benin, EG 2020, etc
 (Hart, Valko, Davenport, Frodge)
 4870 SHRI LANKA SLBC 1/31 1246 tlk/mx bridges, SC, ads (Clark-ON)
 4874.6 IRIAN JAYA Sorong tent 1/12 1210 IN tlk, mx (Davenport-TN)
 1/10 2129 SCI, nx, fair & clear (Clark-ON)
 4875 CHINA Vo Jinling 1/23 1145 orch mx, TP, tlks, CH wailing
 songs, harps (Wallace-MA)
 4880 BANGLADESH RB 2/8 0027 IS, tlk, Koran, het, tnx Johnson (Clark)
 4881.2 IRIAN JAYA Suara Kasih Agung 1/22 1150 pops, SCI, chime IS
 tlks (Valko-PA) 1/29 1305 closing anmts (Clark-ON) 1/9
 2026 tlk, pops, Jak nx, NA (Yamada-JAPAN)
 4885 BRAZIL Rdf. Acreana 1/22 1009 sev IDs, tlk, nice sig (Johnson)
 4885 COLOMBIA Ondas del Meta 1/21 0000 TC, lotto, ads (Bickus-VA)
 4885 KENYA KBC 1/29 to 2113* instl, anmts, choral NA (Orr-VA)
 4890 GABON RFI 1/7 0410 FR nx, cmtry (Davenport-TN) 1/24 0510
 FR nx (Newbury-NE)
 4890 PAPUA NBC 1/9 1345 EZL, crooner, IDs, C&W (Newbury-NE)
 4895 BRAZIL Bare 1/22 0742 campo mx, ID, TCs (Orr-VA)
 4895 COLOMBIA LV del Rio Arauca 0015-0400 futbol, ads, ID, TC,
 mx (Bickus, Davenport)
 4895 PAKISTAN RP 2/1 1501 Urdu nx, ID, fair (Yamada-JAPAN)
 4902p SHRI LANKA SLBC 1/12 2338 Koran, rel reads (Clark-ON)
 4904.5 CHAD Rdf. Nat 0443, 2300* hilife, FR tlk, NA (Clar,
 Bergadano, Davenport)
 4905p CHINA CPBS 1/20 2309 nx, ID? ment Clinton (Clar-NY)
 4909.9 ZAMBIA ZNBS 1/21 0412 EG/lang ment Afr ctries, ID (Lawrence)
 4910.6 HONDURAS LV de la Mosquitia 1/14 0220 rel, sermon, choir
 (D'Angelo-PA) 1/17 0230 ID, Book of Isaiah (Jordan-PA)
 4911.2p SUMATRA Bukittinggil/11 2040 Jak relay, IS, nx, ID (Yamada)
 4911 UNID 2/6 0220 EG rel going on & on (Straus-NJ) See Honduras-sp
 4914.5 PERU R Cora 1/12 1039 IDs, world nx (Frenz-WI) 2/8 1130
 many ment Peru (Straus-NJ)
 4915p CHINA Guangxi 2/6 1214 CH tlks //4760 (Orr-VA)
 4915 COLOMBIA Armonias del Caqueta 1/24 1107 tnx Valko (Johnson)
 1/23 1120 HJ organ, Tc, ID (Valko-PA)
 4915 GHANA GBC 2120 tribal mx, EG nx, ID, call to prayer
 (Davenport, Wallace, Frodge, Hart)
 4923.6v BOLIVIA San Miguel 12/29 0120 ads, mx (Bloisse-DOM REP)
 4925 SUMATRA Jambi 1300 1/24 SCI, weak (Valko-PA) 1/24 1401
 pops, ID, gamelan (Yamada-JAPAN)
 4926.1 PERU unid 1/17 0211 ment Peru, NA 0304 (Field-MI) 1/3
 1045 poss nx, better as San Miguel faded (D'Angelo-PA)
 4935 KENYA KBC *0155-0415 IS, ID, choir, Marley, nx, tribal
 singing (D'Angelo, Clar, Frenz, Laves, Davenport, Bloisse,
 Atkins, Frodge)
 4939.2 BOLIVIA Norte 1/29 1008 tlk, ID, tnx Orr (Johnson-ID)
 4945 BRAZIL RN Porto Velho 2/4 *0855 jingles, echo ID (Orr-VA)

4955 BRAZIL Marajoara 1/7 0230 nx, echo ID, sports (Davenport)
4955 PERU Cultura Amauta 2/6 1102 Quechua tlk, huaynos, ID (Orr)
4960 DOM REP Cima Cien 1/21 0130 salsa, merengue, ID (Bickus-VA)
2/13 0547 jingles, ID, same mx (Lamb-NY)
4960.3p PERU La Merced 1/14 *1059 NA till Federacion wiped out (Valko)
4970 VENEZUELA Rumbos 1/23 0110-0549 dance mx, sports, EG anmt
0454, IDs (Newbury, Davenport, Alexander, Robertson)
4979.5 COLOMBIA Ondas del Ortegua 1/16 0130 LA mx (Newbury-NE)
4980 VENEZUELA Ecos del Torbes 1/23 0125 ID, mx (Newbury-NE)
1/7 0200 lotto, TCs, Besame Mucho, greetings (Bickus-VA)
4985 BRAZIL Brasil Central 2/6 2325 ID, mx, ads (Hart-MN)
4987v SULAWESI Gorontalo 1/23 1327 YL vcls, drifting (Clark-ON)
4991v PERU Ancash 1/15 to 0431* flutes, ID, anmts (D'Angelo-PA)
5000 HAWAII WWVH 1/23 1250 EG TC, ID, fair (Newbury-NE)
5009.4 MADAGASCAR RTV 0257 NA, ID, msgs, vcls, nx (Durden,
D'Angelo, Laves)
5010 CAMEROON Garoua 1/30 0510 nx, IDs, Voice of the North slogan
Musical Jamboree. 1/8 0542 nx, jazz (Clar-NY)
5010 SINGAPORE SBC 1/28 2248 pops, ID, tlk abt WC Fields (Clark)
5015 BRAZIL Pioneira 2/9 0832 morn show, IDs, ads (Orr-VA)
1/23 0901 canned ID, rel tlk (Valko-PA)
5020 NIGER ORTN *0500 NA, flute, ID, prayer, Koran, Afr mx
(D'Angelo, Frenz, Clar, Newbury)
5020 SOLOMON ISL SIBC 1/16 1330 ack donations, fair (Clark-ON)
5025.4p BRAZIL Journal Trans. 1/30 *0857 nx, anmts (Valko-PA)
5025 CUBA Rebelde 1/23 0135 basketball, good (Newbury-NE)
5030 ECUADOR Catolica Nac, 1/17 1030 ID (Bergadano-NJ) 1/27,
2340 MC mx, missionary pgm (Bickus-VA)
5030 VENEZUELA Continente 0151-0517 LA mx, lotto, supermkt ads,
TC, jingles (Bickus, Alexander, D'Angelo)
5032.2 VIETNAM unid believed regional 2/6 1245, 2225 poor (Clark-ON)
5034.5 CENT AFR REP RTV 1/27 2226 lang tlk, ID (Klinck-NY)
5040 ECUADOR LV del Upano 1/30 to 0202* anmts, salsa (Jordan-PA)
1/23 same time ID, addr, anthems (Alexander-PA)
5047 TOGO Lome 2/7 0515 IS, NA, ID, singing (Hart-MN)
5050p CLAND R Freedom via Tanz 1/20 0415 tlk abt freedom, chorus,
sked, pol tlk (Johnson-MD)
5050nf COSTA RICA REE 0500* & 2300* booming in //9530, Axel F
(Alexander, Valko-PA)
5050 TANZANIA RT 1/23 *0328 EG ID, NA, TC, morn anmts (Valko-PA)
1/17 0337 pop/rock, nx, Afr vcls, 100 kW? (Clark-ON)
5055 COSTA RICA Faro del Caribe 1/21 0207 class mx, tlk (Levison)
1/24 0330 EG scripture, ID (Anderson-MI)
5060 CHINA Xinjiang 1/30 IS, MG tlks, ute QRM (Clark-ON)
5060.7 ECUADOR R Progreso 1/12 morns w/IDs, ads (Johnson-MD)
5075 COLOMBIA Caracol 0154, 0947 Big Ben chimes, promos, nx,
IDs, ads (Valko, Jordan, Anderson, Bickus)
5097 PERU R Eco 1/5 0415 ads, IDs, vcls (D'Angelo-PA) 1/18
0455 reggae, ads, IDs, CW QRM (Clar-NY)
5125 CHINA CPBS 1/23 2243 CH vcls, cmtry (Frodge-MI)
5243.3v PERU Tayabamba 1/23 1019 ID, TC, mx, drifting (Valko-PA)
5290 AS RUSSIA Krasnoyarsk 1/23 0953 RS //4485 mx, nx (Orr-VA)
5320p CHINA CPBS 1/17 1236 CH tlks, mx (Lawrence-NY) 1/20 2319
IDs? trad CH mx, severe QRM USCG (Clar-NY)
5323.6 PERU Origen 1/31 1102 echo anmts, NA, ID (Valko-PA)
5486.6 PERU? R Popular is ID hrd here 0027 oldies, SP tlk (Johnson)
0200 rock, anmts, Pet Shop Boys (Valko-PA)
5560.5 PERU LV de Cutervo 1/24 0107 huaynos, IDs (Johnson-GP)
5602.3t PERU? 0958-1050 yelling selections, vy weak (Field-MI)
5660.5 PERU LV de Cutervo 0102 campo mx, ID, TC (Valko-PA)
5700 PERU San Ignacio 0043-0230 ID, mx (Durden, Valko)
5800 CHINA Xinjiang 2/5 1539 sing, //4735 anmts (Murray-OR)
5800 PERU Nuevo Cajamarca 1/28 1050 IDs, folk mx (Durden-GA)
5835 CLAND Patria Libre 0105* ID, mx (Alexander-PA)
5850 USA Christ. Science 12/9 0545 EG mail (Bilec-PA)
5880 AUSTRALIA RA 1/31 2026 EG (Doherty-MA)
5882 UNID 2335 SP tlk, class mx (Levison-PA)

Many tnx to the many newcomers & regulars. 18 st, 1 prov, 2 cties
Next deadline March 19

International Band Loggings

5901-30000 kHz

Wallace C. Treibel
357 N.E. 149th Street
Seattle, WA 98155

- 5930 SLOVAKIA Slovensky Rozhlas in SL *0130, IS, nx, mx, ID, //7345(D'Angelo PA 1/24)
5960 CANADA R Japan relay in EG 0300, Cambodian general election (Bilec PA 1/23)
5970 BRAZIL R Itatiaia in PT 0830, nx, TC's, 3 ID's, g/some QRM (Valco PA 1/22)
5970 PERU R El Sol in SP 1015, nx, many ID's, interview, tlks (Durden GA 1/11)
5985 CONGO RIV Congolaise in FR 0150, hilife mx, tlk, ID's, QRM WYFR (Clar NY 1/1)
5990 MYANMAR VoM in lang 1213, lcl mx, YL host, tlk, nice sig to 1230 (Clark ONT 2/7)
5995 AUSTRALIA RA in EG 1229, "Soundabout", top 100 rx in 1992, g (Pappas SD 2/1)
60099 MEXICO R Mil in SP 1050, SP mx, ID'd XBOI between songs (Frenz WI 1/16)
6005 CANADA CFCX Montreal in EG 1155, relay CIQC MW, "Country Coast to Coast" ID as "Country 600", only 500 watts (Pappas SD 12/25, Fahrer NY 2/7)
6010 CUBA RHC in EG 0140, "DX'ers Unlimited" (Bloisse DOM REP 2/6)
6035 SRI LANKA TWR in Telugu? *1330, distinctive IS, QRM from FEBC (Clark ONT 1/31)
6040 ANTIGUA Deut Welle relay in EG 0135, "European Journal", ID (Newbury NE 12/31)
60698 INDONESIA RRI Jayapura in IN 1309, lcl nx, NA, QRM CFRX Canada (Clark ONT 1/29)
6085 BOLIVIA R San Gabriel in Aymara 0938, ID, political ad, ancmts (Durden GA 1/22)
6085 CANADA Deut Welle relay in EG 6085, nx, editorial, mailbag (Newbury NE 1/17)
6085 GERMANY Bayer RundfK in GM 2138, classical & guitar mx, WYFR s/on at 2159 nearly wiped out sig, pips hrd underneath and ID, f-g until WYFR* (Hardesten NC 1/23)
6087 TAIWAN CBS Taipei in CH 2232, tlk by OM & YL, in clear w/o jamming (Clark 1/23)
60885 CHILE R Esperanza in SP 0758, ID/QTH in EG & SP, relig pgm, sig wiped out by WYFR s/on at 0955 (Valco PA 1/24, Field MI 1/31)
60898 CAMBODIA V of the People in lang 1125, tlk by YL, //49098 (Clark ONT 1/31)
61052v MEXICO XEQM Merida in SP *1130, open carrier from 1101, ID 1202 (Valco PA 1/24)
6110 PHILIPPINES VOA relay in EG 1310, tlk re Clinton inauguration (Newbury NE 1/19)
6130 GHANA GBC Accra in EG 0705, Afr choral mx, ID 0715, tlks, f (Lamb NY 1/24)
6135 SWITZERLAND SRI in EG 0400, tlk on competition in Switzerland (Bilec PA 1/23)
61413v PERU R Concordia 1025, nx, ads, promos, canned ID, g but some QRM (Valco 1/23)
6150nf? CHINA RCI Xian in EG *1329-1356*, IS, ID's, polit cmtry, g (Murray OR 2/5)
6154v ANGOLA ER de Benguela in PT 0120, long tlk, guitar mx, ID 0132 (Valco PA 1/23)
6160 CANADA CKZN Newfoundland relay CBN in EG 1000, ezl mx, TC's, sports, "Daybreak" ID's, CBC nx, interviews (Lamb NY 1/31, Pappas SD, Levison PA 1/15) 300 watts!
6160 CANADA CKZU Vancouver relay CBU in EG 1357, "World Report", wx, p (Pappas 1/7)
6170v COLOMBIA LV de La Selva in SP 0930, Caracol ID, tlk, non-stop pop rx, ad, fqys, promos re new Voz de La Selva (Straus NJ 2/8, Durden GA 1/31, Valco PA 1/24)
6185 VATICAN STATE VR in RM *0509, IS, fanfare, ID, choir, church nx? (Lamb NY 2/10)
62007v PERU VL de Huamanga in SP 1023, nice campo mx, ID's, flute mx (Valco PA 1/31)
6220 BOSNIA RBH in lang 0345, lite & lcl folk mx, pips, ID, f (Alexander PA 1/17)
6235 BULGARIA R Sofia in EG 2125, chants, DX acknowledgmts, off 2129 (Prodge MI)
6245 VATICAN STATE VR in EG 0604, tlk re Cath martyrs, ID, IS, cmtry (Lamb NY 2/13)
62817v PERU R Huancabamba in SP 0115-0206*, SP pops, ID's, NA, p (Alexander PA 1/23)
63295v PERU R Estacion C in SP 1058, ID's, relig pgm (Valco PA 1/24) only 800 watts!
63876v VIETNAM R Yen Bai in VT 1136, hill tribe chants, Asian mx, stn drifts all over the dial even during xmsn - 63876 to 63922, sig wk w/ute QRM (Valco PA 1/31)
65602 IRAQ Rp of Iraq R in lang *0227, clucking chicken IS, NA, Koran (Alexander 1/23)
69102 EQUATORIAL GUINEA R Africa 2000 in SP 2156, ID, girls choir, mx, g (Valco 1/22)
7150 LITHUANIA R Vilnius in EG 0010, chamber mx, commemorative tlk (Bickus VA 1/14)
7180 HONG KONG BBC relay in EG 1600-1614*, "News About Britain", ID (Robertson CA)
7200 SUDAN R Omdurman in AR 0450, fast-paced tlks, mx, ID 0500, g-p (Jordan PA 1/18)
7205 GREECE VOA relay in EG 0245, "Friday Morning" pgm, vg (Straus NJ 2/5)
7230 UNITED KINGDOM R Japan relay in EG 0559*, interview, ID, QTH, f (Lamb NY 1/23)
7245 ANGOLA R Nacional in PT 0416, mx, morning exercise pgm, rap mx (Frenz WI 2/12)
7255 BOTSWANA R Botswana in lang 0246, IS "cows, bells, chickens" (Wolfson OH 1/9)
7255 NIGERIA VoN in EG 0500, ID, "Nigeria Theme", polit tlks, ID, nx (Straus NJ 2/4, Robertson CA 1/20, Newbury NE 12/26)
7260 RUSSIA R Nederland relay Petropavlovsk in EG 1105-1125*, pgm on horticulture, promo, req for recep rpts on relay, QTH, //9860, f (Hardesten NC 2/6)
72673 PAKISTAN Azad Kashmir R via Trakhal in lang 1320, sub-cont chants/vocals, f.
Continues here instead of 47904 (Clark ONT 1/24)

7275 GERMANY Deut Welle in EG 0430, African pgm, tribal stories, mx, ex (Anderson MI)
 72882 VIETNAM VoV in EG *1100, sked, nx, ID, g, formerly on 6449 (Clark ONT 1/31)
 7290 BULGARIA R Sofia in EG 0420, Christian mx, voice over cmntry (Anderson MI)
 7300 RUSSIA Azerbaidzhan R via Balashikha in AZ 0627, polit disc, 0643 mx, 0659 ID in
 AZ, 0700 IS, bells, g (Robertson CA 1/20)
 7310 VATICAN STATE VR in EG *2242, IS, ID, tlk re Pope in Africa (Lamb NY 2/10)
 7325 UNITED KINGDOM BBC London in EG 0210, nx, interviews, pgm mx, ID (Robertson 2/1)
 7345 SLOVAKIA Slovensko R in SL *0130-0200*, R Prague IS first, then 6 note IS same
 fgy but weaker, ID, nx?, mx bridges, //5930 (Jordan PA 2/1)
 7370nf BELGIUM R Vlaanderen Int in EG *0028, IS, ID, nx, tourism feature, lcl pop rx,
 //9930, mailbag, wx (Lamb NY 1/23, Jordan 1/25, Alexander PA 1/23, Clar NY 1/25)
 7375 COSTA RICA RFPI in EG 0150, "Earthwatch Radio", speech (Carson OK, Newbury NE)
 7550 SO KOREA RK in EG 2227, DX pgm, letterbox, ID, QTH, f-p (Clar NY 1/24)
 7600 ECUADOR HD210A Time Stn in SP 0900, pips & anct every min (Bloise DOM REP 2/7)
 7705nf? ITALY RAI in IT 0054-0305, probably feeder fgy, ballads & instrmls, 5+1 pips
 before hr, nx, ID in EG, f-p (Hardester NC 2/5)
 8638 AUSTRALIA VNG Time Stn in CW 1228, beeps w/ID in code on 1/2 hr (Klinck NY 1/15)
 9425 GREECE VGG in EG 2335, nx, ID's, IS, vg (Straus NJ 2/9)
 95049v PERU R Tacna in SP 1010, nx, ID's, ads, TC's, promos (Durden GA 2/1, Valko PA)
 9515 BRAZIL R Novas de Paz in PT 0116, relig tlk & mx, ID, fgy, promo (Clar NY 1/2)
 9535 SRI LANKA R Japan relay in EG 1422, "In Conversation", ID, lang (Pappas SD 2/1)
 9550 CUBA RHC in EG 0509, nx, "Inside Story", fax/E mail #'s, sports (Lamb NY 1/28)
 9560 JORDAN R Jordan in EG 1545, ID, US pops, nx, wx, sked (Clar NY, Alexander PA)
 9565 BRAZIL R Universo in PT 0407, folk songs, TC's, ID's, fgy, f (Lamb NY 2/3)
 9565 SEYCHELLES FEBA in FR 1833*, IS, ID's?, relig tlk & mx, f (Clar NY 1/15)
 9570 PORTUGAL R Port Int in EG 0245, ID, hilites of 1992 in Portugal (Bickus VA 1/8)
 9580 ALBANIA R Tirana in EG *0230-0300*, ID, nx, martial mx, econ tlk, cmntry re
 housing shortage (Frenz WI 2/2, Jordan PA 2/6, Carson OK 1/10)
 9580 YUGOSLAVIA RY in EG 0100, IS, ID, nx, lcl pop mx, sports roundup, signal wiped
 out by R Tirana s/on 0128 (Alexander PA 1/10, Davenport TN 1/12, Newbury NE 1/2)
 9605 CZECH REPUBLIC R Prague in EG 2108-2130*, "Off the Wall", ID, IS (Lamb 1/24)
 96124 INDONESIA RRI Jayapura in IN 1325, ezl mx, tent ID 1329, IS, lcl nx, low level
 anncr, NA, Lagu vcl mx (Clark ONT 2/6, Valko PA 1/24)
 9615 SRI LANKA Deut Welle relay in EG *0200, IS, ID, pips, nx, f-p (Jordan PA 1/20)
 9625 BOLIVIA R Fides in SP 1100, ID, nx, ad for Cerveza Pastena, g (Durden GA 2/2)
 9640 ANTIGUA BBC relay in EG 0733, nx, cmntry on Clinton inaug (Robertson CA 1/24)
 9645 BRAZIL R Bandeirantes in PT 0357, ID, jingles, US pop rx, f/QRM (Lamb NY 2/3)
 9655 SWAZILAND TWR in EG 0450, tlk on repentance, into Afr lang 0530, g (Newbury NE)
 9670 ANTIGUA Deut Welle relay in EG 0500, ban on oil tankers in Europe (Bilec PA)
 9705 SAUDI ARABIA R Riyadh in EG 2035-2100, drama, ID, nx, temp data for many ME
 & Europ cities, TC, f-g (D'Angelo PA 1/23) ED: Is this repl for Jeddah per WRTH?
 9715 QATAR Qatar BS Doha in AR 2040-2140*, AR mx, ID's, tlks, NA (Jordan PA 1/30)
 9720 SRI LANKA SLBC in EG 1420, opera & pop mx, ID, pips, nx (D'Angelo PA, Clark ONT)
 97202 ANGOLA R Nacional in PT 0710, Afr pop mx, DJ chatter, //119548 (Alexander PA)
 9725 BRAZIL R Clube Paranaense in PT 0805, ID, nx, beer ads, soccer championships, TC
 (Durden GA 2/5, Valko PA 1/22)
 9740 SINGAPORE BBC relay in EG 1609, nx, feature, ID, TC (Robertson CA, Davenport TN)
 9745 SO KOREA R Korea in EG 1253, Chinese calendar discussed, g (Carson OK 1/9)
 9800 FRENCH GULIANA RFI relay in FR 0430, reporters calling in w/rpts, g (Newbury NE)
 9815nf? CUBA RHC in EG 0134-0158*, "Breakthrough", ID's, "Havana Showcase" (Lamb 2/1)
 9820 PHILIPPINES FEBC in Cantonese 1209, choral mx, tlks, ID, ezl mx, f (Lamb 1/17)
 9830 CROATIA CR Zagreb in CR 2145, tlks, ID, QTH, organ mx, p (Jordan PA 1/20)
 9840 KUWAIT R Kuwait in AR 2300, ID 0000, nx, mx, tlks, ID (Vadino WA 2/10)
 9860nf RUSSIA R Nederland relay in IN 1203, ID's, tlks re Vietnam, pops, nx (Lamb 2/13)
 9870 AUSTRIA RAI in GM/EG 0310, "Report from Austria", ID's, f (Pappas SD 2/2)
 9880 AUSTRIA RAI in GM/EG 1930, ID, nx, Strauss mx, into GM 1959 (Alexander 1/24)
 9895 MADAGASCAR R Nederland relay in DT 0331, nx, tlk, sports, ID (Robertson CA 1/25)
 9900 EGYPT R Cairo in EG 2110, tlks on US action against Iraq (Davenport TN 1/13)
 9950 INDIA AIR in EG 2110, polit tlks, ID, QTH, pgm notes, nx, mx (Jordan PA 1/18)
 11402usb ICELAND INBS in IC 1848-1930, reggae & classical mx, ID's, bells, mx, sports,
 IS, f-g (Lamb 1/24) in IC 2315, tlk, nx?, ID's, f, //9275 (Clar NY 1/10)
 11530 LEBANON Wings of Hope in EG 0115, Dr Gene Scott, ID, QTH, f-p (Straus NJ 2/10)
 11587 ISRAEL Kol Israel in EG 2001, nx magazine, "Sportlight", ID (Tucker GA 2/6)
 11620 INDIA AIR Bangalore in lang 1745, into EG 1800, nx, tlk, mx, ID's (Pappas SD,
 Bilec PA, Davenport TN) in EG 2045, ID, fqys, nx, vg (Straus NJ 2/10)
 11625 VATICAN STATE VR in EG *0459, IS, drums, Afr service, ID, church nx (Lamb 2/10)
 11680 FRENCH GULIANA China R Int relay in EG 0415, sports, ID, mx (Anderson MI 2/7)

11680 GABON R France Int in FR 0648-0656*, tlk, mx bridges, ID (Robertson CA 1/24)
 11685 RUSSIA R Ala in RS 1309, folk mx, nx, IS, ID, //7400, 11965, f (Lamb NY 1/17)
 11700 GUAM KTWR R Merizo in EG 1420, description of hymn just played (Field MI 1/15)
 117148v ALGERIA VO Palestine relay in AR 1658, nx, tlk, pop mx, //15205 (Valco PA 1/23)
 11735 URUGUAY R Oriental in SP 2309-0032*, ID's, slogans, noticias, ad/jingles, nx, L Am romantic ballads, bells, rpts, cmntry (Clar NY 1/27, Valko PA 1/22)
 11780 BRAZIL RN da Amazonia in PT 0830, ID's, station promos, pop rx (Lamb NY 1/30)
 11800 ITALY RTVI in IT 2357, lite US pop rx, ID 0059* (Robertson CA 1/25) in EG 0100, IS, chimes, mx, ID, nx & cmntry, //9575 (Newbury NE 1/21)
 11800 SRI LANKA SLBC in HD/EG 0115, relig pgm?, ID in EG 0129 (Clark ONT 1/25)
 118054 GEORGIA Georgian R in EG/RS *0600-0656*, ID, nx, folk mx, f-g (Alexander PA 1/9)
 11855 BRAZIL R Aparecida in PT 0209, Brazilian pops, ID's, slogans, f (Lamb NY 2/2)
 11855 CANADA RCI in EG 1343, excellent native American drama, ID (Pappas SD 2/1)
 11855 AUSTRALIA RA in EG 130, ID, fqy & times, "News Panorama", g (Anderson MI 2/6)
 11860 IRAQ R Iraq Int in AR 0250, tlks re Iraq & "holy war", g (Jordan PA 1/18)
 11920 MOROCCO RTVM in FR 1906, classical mx on 1/23, pop mx 1/24, f (Hardester NC)
 11925 BRAZIL R Bandierantes in PT 0228, ID's, nx w/remotes, ad?, //6090 (Lamb NY 2/2)
 119379 CAMBODIA V of the People in EG/FR 0000, NA, tlk re lcl situation, ID, vocals, EG close out w/ sked 0014, into FR, muffled audio, f-g (Clark ONT 1/29)
 11945 UNITED ARAB EMIRATES R Dubai in EG 0331, nx, ID, lcl wx, feature (Tucker GA 2/9)
 11995 PHILIPPINES FEBC in EG 1415, ID, fqy, QTH, rel drama, nx (Straus NJ, Pappas SD)
 12010 UKRAINE R Ukraine in EG 0345, press review, pop mx, g (Davenport TN 1/13)
 12015 GABON R France Int relay in FR 1703, Jean-Luc Ponty mx, ID, nx, f (Lamb NY 1/23)
 12085 SYRIA R Damascus in EG 2050, AR mx, ID, cmntry on ME affairs (Tucker GA 2/7, Jordan PA 1/18, Davenport TN 1/14) in AR 2250, AR mx, bad het (Newbury NE 1/14)
 13690 RUSSIA D Welle relay Zhigulevsk in GM 1645, tlk, mx bridges, ID (Klinck NY 1/20)
 13760 NO KOREA R Pyongyang in EG 0048*, patriotic mx, poems, ID, sked, NA (Lamb 1/25)
 13770 NETHERLANDS R Nederland in EG 1523, "Research File", nx, ID, p (Pappas SD)
 13830 CROATIA CR Zagreb in EG 2203, nx re civil war in Bosnia, f (Anderson MI)
 15145 SEYCHELLES FEBA in Amharic *0329, IS, ID, Christian mx, relig tlks (Lamb 1/25)
 15210 IRAQ R Iraq Int in AR 1850, prayers, fanfare, tlk, AR mx, ID's (Jordan PA 1/18)
 152101v EGYPT R Cairo in Hausa/Yoruba 1900-2202*, Koran, lite mx, lcl AR mx, s/off with NA, not to be confused w/Iraq which was not hrd (Alexander PA 1/23-24)
 15250 IRAQ R Iraq Int in EG *1359-1653*, NA, ID, Koran, AR mx, press review, mailbag, (Alexander PA 1/24, Vadino WA 2/10, Davenport TN 1/14)
 15335 MOROCCO RTVM in AR 1959, AR mx, NA, ID, nx re Saddam Hussein, f-g (Lamb 1/18)
 15345 MOROCCO RTVM in AR 1523-1710, ME mx, Qur'an recitation, f (Pappas SD 1/12)
 15360 MOROCCO RTVM in AR 1409, AR mx, tlk, //15345 (Davenport TN 1/14)
 15425 AUSTRALIA ABC Perth VLW15 in EG 0035, YL hosts phone-in show, f (Clark ONT 1/29)
 15445 BRAZIL R Bras in EG 1210, sambas, ID (Davenport TN, Bickus VA, Tucker GA 1/26)
 15540 BELGIUM R Vlaanderen Int in DT *1659-1755, special bcst to Belgium forces in Somalia - Sun only, IS, ID, pop/rap mx, regular pgm 1759, f (Alexander PA 1/31)
 21605 UNITED ARAB EMIRATES R Dubai in EG 1330, ID, nx, arts & craft (Davenport 1/13)
 21810 BELGIUM R Vlaanderen Int in EG *1400-1425*, IS, ID, TC, press review, QTH, sked, "Belgium Today", tlk re labor problems (Jordan PA 1/29, Davenport TN 1/13)
 15750 AUSTRALIA RA in EG 0801, testing with 250 kw xmtr (Bloisse DOM REP 1/29)

CLANDESTINE STATIONS

6270 R Patria Libre - Colombia in SP 1140, long tlks, LA song, ID (Valko PA 1/9)
 6305 La Voz del Cid - Guatemala in SP 1010, anti-Castro harangue, ID (Straus NJ 2/8)
 9942 La Voz del Cid - Guatemala in SP 1343, phone-in interview, ID (Tucker GA 1/23)

Tom Davies from South Africa advised me by Aerogram that BBC has started experimental use of the SABC xmtr at Meyerton as an additional relay for the region. Sked is as follows:

1745-1900 on 15420 and 0700-0730 on 17790

There may be some confusion regarding the Indonesian reported above on 96124 (actually 961327 per David Clark). PWBR and WRTH both note Samarinda on 96144 but no mention of Jayapura. Clark noted Jayapura on 961237 after other station on 961436 signed off at 1416. Clark believes the 961237 outlet to be a MW relay for Jayapura. However, it may be only a temporary thing leading up to Ramadan or whatever. In any event, you had better have your earphones on tight when attempting to ID these babies!

English Schedules

Tom Sundstrom
P.O. Box 2275
Vincentown, NJ 08088-2275
MCI Mail 244-6376
Fax 609-859-3226
PICS Online RBBS 609-753-1549
Genie T.SUNDSTROM



Prepared 2/27/93 at 6:10 PM.

This month, thanks to David Allen (KCBI), Steve Bohac (NJ), George Jacobs and Associates (DC), Kunitoshi Hishikawa (NHK), Jon Klinedinst (PA), Tetsuya Kondo (ABI/Japan); Jonathan Marks (R Netherlands), Richard Mensham (BBCM), and Andy Sennitt (WRTH).

Notes

On January 27 I received a call from David Allen, Chief Engineer of KCBI. I had the wrong transmission times and target areas in the January column. KCBI is not quite 24 hours, despite what other sources suggest. Time is needed to do the frequency and antenna changeovers and adjustments. The 50 kw transmitter is near Frisco, TX, in Collin county north of Dallas. Two 10 db gain corner reflector antennas are used, one pointed in each direction. The definitive schedule appeared in last month's listing (which went to press after this column was written). David, thanks for the schedule data and interesting chat.

On January 15 R Portugal announced a new, simplified address for mail was announced: *Radio Portugal, PO Box 1011, Lisbon 1001.*

I keep forgetting to catch R Japan's *Media Roundup* 0330 Sunday on 5960, but at 1530 I can't hear the 9535 direct from Japan. 9535 is intended for reception in wNAM. Surprise! The Gabon relay on 15355 15-16 UT is received fairly well here in NJ.

On February 7 there were two announcements. *One:* With the installation of a new "sending system" completed in February, in April R Japan will increase its daily output to 60 hours. *Two:* Ian McFarland leaving R Japan after his two-year assignment and returning to Canada in

the end of March. His weekly participation on *Media Roundup* will end, but he will have a receiver review program segment airing on the last UT Sunday of each month. Larry Magne will again be involved in this effort that starts in April. It apparently will be similar to the feature airing on RCI's *Shortwave Listener's Digest* and later on *Media Roundup*. Ian plans to continue working on a part-time basis, continuing the international broadcasting series now airing on *Media Roundup* and launching some additional projects. Ian will be representing RCI and RJ at the Dayton Hamvention's ANARC SWL Forum and at the ODXA event a week later, and hopes to make it to the seventh Winter SWL Festival next year.

For those with RTTY decoding equipment, the Iraqi News Agency has moved its English language teletype press service to 10162.5 (50/425/N), down from 13524. Per Richard Measham, this occurred on February 1. Monitoring here shows the signal is a bit more difficult to copy on the lower frequency due to the daylight path, but the schedule seems to be the same as before: approximately 13-22 UT. This RTTY service and the 14-17 UT R Iraq Int'l release are more reliable than any of the RII European releases nominally at 20-22 and 22-24, not often heard.



Reality Check

The R Tashkent DX tip that's made the rounds these past months in the voice and print media says the schedule is 17815 at 12 and 1330 UT. It just isn't true. The 17m frequency is 17745, parallel to 15470, 9540 and 5945 kHz as they've been since last November. I can hear all the outlets here.

The new CIS relays of R Netherlands are working well, delivering excellent signals in to the target areas. Here in NJ I note

Authorized Dealer

JRC

& Skywaves Antennas

PC Software by W2XQ

English Language SWBC Schedules
JRC/Kenwood Receiver Control
Utility Logbook

Send #10 SASE (2 IRCs) for
catalog or download off the
Pics OnLine! BBS at
609-753-2540.

TRS CONSULTANTS, PO Box 2275-NA, VINCENTOWN, NJ 08088-2275

especially good reception on 9860 via Irkutsk; in mid-February the 1030-1130 release came around sunset at the transmitter site, about a half-hour before sunrise here. 7260 via Petropav was better in the first hour. I can't be sure, but I think 9860 is traveling long-path, 7260 short-path. After 1030, the



latter picks up 4 s-units on the 90-ft high 350-ft inverted-L antenna favoring reception from the NW; the

lower antennas don't hear very well. I don't hear any long path echoes on 9860, but that signal seems 2-3 s-units higher on the 80-ft high 250-ft inverted-L favoring the SE. And I don't hear anything I recognize as polar flutter.

The External Service of Slovak Radio is adding programs in English, French and German as of April 1. Thanks to Jonathan Marks for forwarding the information. You'll recognize the frequencies as those used by R Prague. Steve Bohac provides the mailing address: *Slovak Radio, Mýtna 1, 81290 Bratislava, Slovakia.*

Glenn Hauser's commercial effort *DX Daily* went on hiatus with the last show on February 26. He hopes to return the show to the air, perhaps in April, perhaps on WHRI, perhaps at 0130 UT; listen to *World of Radio* for details. WWCR has come up with temporary time slots for *World of Radio* and *Signals*: UT Monday 1330 and UT Sunday 1605, respectively. The time may be sold at any time. Speaking of *Signals*, the personnel now only produces a new show every two weeks. Each show repeats in the following week. I noted the repeats starting last December or so, and recent GENIE postings suggest this will be the norm for the foreseeable future.

WWCR transmitter #3 may be on the air by April 1, testing on 5810 and 15610 kHz.

Do you read rec.radio.shortwave on the Internet? I picked up an item that Radio Netherlands was making a one-time only broadcast on February 24 at 1900-2115 UT via the Krasnodar, Georgia, 1000 kw transmitter on 7400 kHz. The signal started out being usable, but wound up being very good. It was a football game between the Netherlands and Turkey—in Dutch.

Wolf Harranth of ORF sent details of the resurrected *SW Panorama* show in response to my inquiry. In an February 16 email message to me he wrote: "Tom, the problem is they have not yet really decided what to do;

every Saturday, or alternating with the letterbox program, or resume *ASWP* every Sunday. For the time being you have to check the latter part of *Report from Austria* every Saturday... I am trying not simply to pass on the stuff from the German program but something for their/your particular interest/target zones. I'll keep you informed." I haven't added the data to the files yet.



After nearly 30 years at HCJB, *Happiness Is* will be coming to a halt when the show's host, Dee Baklenko, will leave Ecuador and the radio station. On Saturday,

May 1 Dee will air a live "thank you call-in" show. *Happiness Is* airs Tuesdays and Thursdays.

Jon Klinedinst comments that the BBC around 0530 on 6015 is quite strong. This frequency is not listed (in my sources) to NAM, nor does it show in a tentative summer schedule. It may not be around for long. He also notes the Voice of Nigeria on 7255 sometimes signs on before 05 UT, with good signals.

Yaesu FRG-100

Gilfer SW brought the new—at least new to the states—Yaesu FRG-100 to the 6th annual Winter SWL Festival. Some of us were playing with this receiver, and I



had the opportunity to compare it with Elton Byington's Lowe HF-150 and several other radios around the room. I'm sure Alan Johnson will have more to say about the FRG-100 in the not-too-distant future, but (in my opinion) this receiver just has to be a winner. It's SRP is just under \$600, and the street price range is \$519 to \$550. Bottom line: the audio sounds good, I don't miss the keypad and ECSS, it's easy to use but, as expected, the AM filters could be better. If you are thinking about buying a high-end portable radio like the Sony SW-77 or the Lowe HF-150, and portability isn't an issue, I'd recommend you at least look at the FRG-100 before you plunk down your money. You may be surprised. Just a word of caution: it won't match the performance of the \$1,000 tabletop receivers offered by JRC, Kenwood, and Drake. Take a look at the review in the 1993 *WRTH* for details.

English Language Schedules
 By Start Time, Changes Entered Between
 1/28/93 and 2/27/93
 Compiled by Thomas R. Sundstrom, W2XQ

Start Time (UTC)	End Time (UTC)	Country	Station	Freq. #1	Freq. #2	Freq. #3	Freq. #4	Freq. #5	Freq. #6	Freq. #7	Freq. #8	TARGET	Target Area	Notes	Record Last Updated
START/END COUNTRY															
0000	0100	USA	VOAE As	17820	17735	15290	15185	11760	9770	7290		eAs/eAs/Pac			2/12/93
0000	0027	Slovakia	Slovak Radio	9580	5930							NAm		as of 1 April	2/9/93
0100	0200	Japan	R Japan	17845	17835	15195	11840	11815				GOS/Asia/NAm		#4 Sri Lanka	2/25/93
0130	0200	Austria	ORF	9875	9870	6015						NAm/SAm			2/25/93
0300	0330	Japan	R Japan	17810	17765	15325	15230	11725	5960			GOS/NAm/CAL/Asia		Reg #3&5] #3 Fr Gu	2/25/93
0300	0400	USA	VOA/Al	11890	11835	9885	9715	9575	7405	7280	7265	Africa		15752 USB -0700	2/12/93
0400	0430	USA	VOA/Al	11890	11835	9885	9715	9575	7405	7280	7265	Africa			2/26/93
0400	0600	USA	WSHB/2	9455								wNAm		315 deg	2/25/93
0430	0500	USA	VOA/Al	9575	7405	7280	7265	6035				Africa			2/12/93
0500	0600	Japan	R Japan	21610	17860	17810	17765	15230	11725	7230	6085	GOS/As/NAm/Eu		#788 v UK	2/25/93
0500	0600	USA	VOA/Al	15600	12080	9635	7405	6035				Africa			2/12/93
0600	0700	USA	VOA/Al	15600	12080	11925	9635	9530	7405	6035		Africa			2/12/93
0600	0800	USA	WSHB/1	9840								Eu		25 deg	2/25/93
0600	0800	USA	WSHB/2	9455								wNAm		315 deg	2/25/93
0700	0830	Ecuador	HCJB	21455	11835	9600						Eu		#1 USB	2/13/93
0730	1130	Ecuador	HCJB	21455	11925	9745						sPac			2/13/93
0800	1100	USA	WWCR/1	9370								Eu/ME/nAl		alt 12160	2/12/93
0930	0957	Slovakia	Slovak Radio	11990	9505	7345						AU		as of 1 April	2/9/93
1000	1200	USA	VOA/Am	15120	11915	9590	7405					Caribbean/Americas			2/12/93
1200	1400	N Mariana Is	KHBI	13625	9425							sAs/Aus/NZ		285/195 deg	2/25/93
1200	1400	USA	WCSN	15665								Eu		60 deg Sa-Su	2/25/93
1400	1500	Japan	R Japan	11865	11815	9535						GOS/Am/As			2/25/93
1400	1500	USA	VOA/S As	15425	15395	9760	9645	7125	6110			sAs			2/12/93
1400	1600	USA	WSHB/1	13710								eNAm/Car		25/173 deg Sa-Su	2/25/93
1500	1600	Japan	R Japan	15355	11865							GOS/sA/nAm		#1 v Gabon	2/25/93
1530	1540	Greece	V of Greece	17525	15645	15630						NAm/nEu		News/Eng ex Su	2/7/93
1600	1800	N Mariana Is	KHBI	13625	11580							Al/sAs/India		255/310 deg	2/25/93
1600	1800	USA	WSHB/1	13710								eNAm/Car		25/173 deg Sa-Su	2/25/93
1700	1800	Japan	R Japan	17775	11865	9535	7140					GOS/ME/nAl/Am/As		#1 Sri Lanka	2/25/93
1800	2000	N Mariana Is	KHBI	9430	9355							Aus/NZ/Eu/ME		165/325 deg	2/25/93
1830	1857	Slovakia	Slovak Radio	7345								Eu		as of 1 April	2/9/93

1900	1930	Japan	R Japan	11865	9535	GOS/Oc/Am	2/25/93
1905	1915	Greece	V of Greece	11645	9375	Eu	News/Eng ex Su
2000	2200	N Mariana Is	KHBI	15405	13625	China/Japan/Indon	310/240 deg
2000	2200	USA	WCSN	13770		Eu	60 deg
2000	2200	USA	WSHBI/1	15665		eNAmy/Eu	25 deg
2100	2200	Japan	R Japan	17890	15430	GOS/Oc/As/Eu	#4 v Gabon
2100	2200	USA	VOA/ME	15205	11960	ME/nA/Eu	2/25/93
2140	0400	New Zealand	R New Zealand Int'l	17770	8040	Pacific	2/26/93
2200	2400	USA	VOA/E AS	17820	17735	eAs/se/As/Pac	elf 3/22 move->15120
2200	2400	USA	WCSN	13770		sEu/wA/	2/21/93
2300	2400	Japan	R Japan	15430	9750	GOS/As/Eu	90 deg
				6150	6050		#3&4 v UK
							2/25/93
							2/25/93

English Language DX Shows

By Day of Week

Changes Entered between 1/28/93 and 2/27/93

Compiled by Thomas R. Sundstrom, W2XQ

Day	Program	Xmsn Show Start Time	Country	Station	Freq. #1	Freq. #2	Freq. #3	Freq. #4	Freq. #5	Freq. #6	Freq. #7	Freq. #8	Freq. #9	Freq. #10	Program Notes	Record Last Updated
Sunday	World of Radio	0000	0405	USA	WWCR/1	7435									bi-weekly	2/21/93
Sunday	Signals	0000	0435	USA	WWCR/1	7435									new show every 2 wk	2/21/93
Sunday	Signals	1100	1605	USA	WWCR/1	15685									temporary time slot	2/26/93
Monday	Signals	0000	0600	USA	WWCR/1	7435									temporary time slot	2/26/93
Monday	World of Radio	1100	1330	USA	WWCR/1	15685									temporary time slot	2/26/93
Saturday	World of Radio	1600	2130	USA	WRNO	15420										2/11/93

the **QRPV** page

COMMITTEE TO PRESERVE RADIO VERIFICATIONS

JERRY BERG, Chairperson • 38 Eastern Ave. • Lexington, MA 02173 • (617) 861-8481

VE9JR

WINNIPEG
1 PM
AUG 30
933

Authorized Courtesy Call Letters: CJRX
Communicating the fact that under these call letters the station was first in Canada to provide regular daily concert programs on short wave

WINNIPEG, MANITOBA, CANADA
 Power: 2000 Watts, Wavelength 25.6 Metres

We are pleased to verify your reception of VE9JR on August 11th, 1933 and are glad to know that you heard our station. Many thanks for your interesting report.

James Richardson & Sons, Limited
 Grain Merchants — Established 1837
 Stocks — Bonds

STUDIO: ROYAL ALEXANDRA HOTEL, WINNIPEG

2000 Watts
€JRX
 11,720 kc

WINNIPEG, MANITOBA
 CANADA

2000 Watts
CJRO
 6150 kc.

Canada's Pioneer Short Wave Stations

Our call letters were changed from €JRX and €JRO to CKRX and CKRO on 1 October, 1945. Thank you very much for your letter.

It is pleased to verify your reception of CJRX on April 4, 1938 as stated in your communication, and are glad to receive your report.

JAMES RICHARDSON & SONS, LTD.
 Grain Merchants since 1837
 Mitchell

CJRX-CJRO

WINNIPEG
4 PM
MAR 24
1938

CJRX is the pioneer Short-wave broadcast station in Canada and the first station in Canada to provide regular daily broadcasts of concert programs.
 CJRX — WINNIPEG, MANITOBA, CANADA
 2000 Watts
 CJRO — WINNIPEG, MANITOBA, CANADA
 2000 Watts

We are pleased to verify your reception of CJRO-3-3-38 and are glad to know that you have heard our station. Many thanks for your interesting report.

James Richardson & Sons, Limited
 Grain Merchants — Established 1837

STUDIO: ROYAL ALEXANDRA HOTEL, WINNIPEG

2000 Watts
CKRX
 11,720 kc.

WINNIPEG, MANITOBA
 CANADA

2000 Watts
CKRO
 6150 kc.

Canada's Pioneer Short Wave Stations

We are pleased to verify your reception of CKRX on Feb 7th, 1944 as stated in your communication, and are glad to receive your report

TRANSCANADA COMMUNICATIONS LTD.

J. H. Camp
 12211B (024)

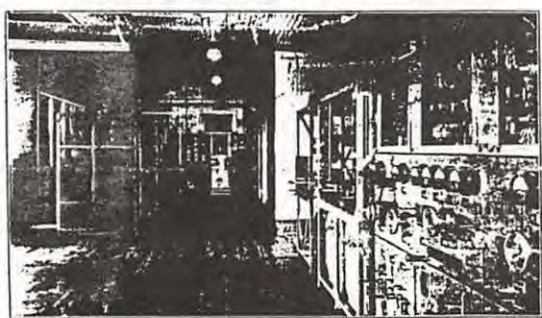

WINNIPEG SHORT-WAVE STATION
 JAMES RICHARDSON & SONS, LIMITED
 OWNERS AND OPERATORS OF
 CJRX — Home for Saskatchewan, 411 metres
 CJRO — Home for Saskatchewan, 411 metres
 VERC — Winnipeg, Manitoba, 49.5 metres
 VEVJR — Winnipeg, Manitoba, 23.6 metres

According to these well designed QSL's, James Richardson & Sons, Ltd., Winnipeg grain merchants, were the first SWBCers in Canada. They started out as VE9JR (11720) and VE9CL (6150), later becoming CJRX and CJRO, then (in 1943) CKRX and CKRO. Their 2 kw. was widely reported in the U.S. Any old timers know what happened to this one? JB

A Committee of the Association of North American Radio Clubs

the **CPRV** page

COMMITTEE TO PRESERVE RADIO VERIFICATIONS

JERRY BERG, Chairperson • 38 Eastern Ave. • Lexington, MA 02173 • (617) 861-8481

RADIO ETHIOPIA
 P. O. Box 1020 ADDIS ABABA

From	Kc	Km
144	2000	4000
Wavelength	1500	150
Frequency	200	20

TIME: 10:00 AM (EST) 10:00 AM (GMT)
 144 2000 4000 2000
 1500 200 20

LANGUAGES: Amharic, English, Oromo
 K'ya, French, etc.

YOUR QSL CONFIRMED

Frank Peters
 820 W. 14th Street
 Chicago, Illinois, 60606
 U.S.A.



Many of us can remember when the shortwave broadcasting scene in Ethiopia changed radically. It was 1978. The standard Ethiopian log had been Radio Ethiopia, whose QSL is shown at the top left. Note the photograph of long time Ethiopian Emperor Haile Selassie on the postage stamps. When the forces of the revolution took over the country, the station was closed down and replaced by the Voice of Revolutionary Ethiopia.

+++ The Voice of Revolutionary Ethiopia devised a convenient strategy for increasing its coverage: take over someone else's station, specifically ETLF, Radio Voice of the Gospel, a high power Christian broadcasting station owned by the Lutheran World Federation. It had been transmitting since 1963 with 100 kw. from a 40 acre site near Addis Ababa. +++ CPRV concentrates on QSL's from broadcasting stations, SW and MW (amateur stations only in special cases). We are always happy to learn of individual QSL's, or entire collections, that are in need of a new home. Full information can be obtained for a business size SASE to the address shown above. If you would like information on the CPRV Registered Collections Program and how you can place stickers on your QSL albums indicating your wish that they be donated to CPRV when the time comes, send a business size SASE to Registered Collections Program Coordinator John C. Herklmer, P.O. Box 54, Caledonia, NY 14423, or to yours truly. 73 -- 

Proclaiming Christ to His World



**RADIO
VOICE
OF THE
GOSPEL**

P. O. Box 654
Addis Ababa
Ethiopia

ETLF

RADIO VOICE OF

THE GOSPEL



ETLF
 P.O. BOX 654
 ADDIS ABABA
 ETHIOPIA

Proclaiming Christ to His World

North American Shortwave Association
45 Wildflower Road
Levittown, Pennsylvania 19057

First Class Mail
U.S. Postage
PAID
Levittown, PA
Permit No. 319

FIRST CLASS MAIL



The Journal of the
North American Shortwave Association

ISSN 0160-1989

Executive Director: Bob Brown, KW3F
238 Cricklewood Circle, Lansdale, PA 19446

Publisher: Bill Oliver, 45 Wildflower Road,
Levittown, PA 19057

Executive Council: Jerry Berg, Bob Brown,
Dr. Harold Cones, Gerry Dexter, Glenn Hauser,
Don Jensen, Bill Oliver

EDITORIAL STAFF

Managing Editor: Bob Brown, KW3F
238 Cricklewood Circle, Lansdale, PA 19446

DXer's Forum: Send All Inputs to - 238 Cricklewood
Circle, Lansdale, PA 19446

Easy Listening: Richard Cuff, 213 Parkview Ave.,
Allentown, PA 18104-5323

NASWA Portraits: Jerry Klinck, 43 Lein Road,
West Seneca, NY 14224

Listener's Notebook: Dan Ferguson, P.O. Box 2604,
Dale City, VA 22193

Technical Topics: Joe Buch, N2JB, 2008 Mozart
Circle, Virginia Beach, VA 23454

QSL Report: Sam Barto, 47 Prospect Place, Bristol,
CT 06010

Distributing Editor: Vernon Hyson, 5410 Camp
Stewart Rd., Charlotte, NC 28215

Tropical Band Loggings: Sheryl Paszkiewicz, 1015
Green Street, Manitowoc, WI 54220

International Band Loggings: Wallace C. Treibel,
357 N.E. 149th St., Seattle, WA 98155

Scoreboard: Jerry Lineback, 6361 Shore Drive,
Douglasville, GA 30135

NASWA Awards: Dr. Harold Cones, 2 Whits Court,
Newport News, VA 23606

English Schedules: Tom Sundstrom, W2XO
P.O. Box 2275, Vincentown, NJ 08088-2275

Listener's Library: Skip Arey, WB2GHA
P.O. Box 644, Waterford Works, NJ 08089

Destinations: Mitch Sams, 779 Galilea Court, Blue
Springs, MO 64014; Don Moore, 11434 140th St.,
Davenport, IA 52804-9538; Bill Kurrasch, 5607
Lincoln Rd., Ontario, NY 14519

Equipment Reviews: Alan Johnson, N4LUS
6001 Goldsboro Rd., Bethesda, MD 20817

Radio Stamps: Neil Carleton, P.O. Box 1644,
Almonte, Ontario K0A 1A0, Canada

The Company Store: Fred Kohlbrenner, 2641 S.
Shields St., Philadelphia, PA 19142

MEMBERSHIP FEES:

North America (First Class Mail)	\$25.00
Overseas (Air Mail):	
<i>Central America, Caribbean, Venezuela</i>	
<i>& Columbia</i>	\$29.00
<i>South America and Europe</i>	\$29.00
<i>Asia, Africa and Pacific</i>	\$32.00

All remittances must be in U.S. funds and mailed to:

NASWA
45 Wildflower Road
Levittown, PA 19057
U.S.A.

